

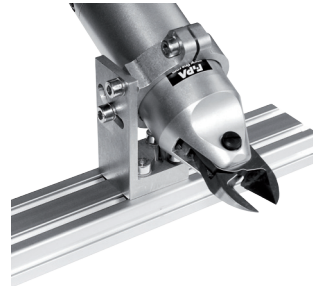

Clamps with angle brackets – for direct mounting

Mounting air nippers on EOAT or special machines

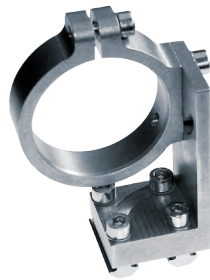

Air nipper GT-NR20 assembled on extrusion SLine

Product notes

- > Mounting bracket for installation on grippers or special machines
- > Easy positioning of the air nipper thanks to 2x 90° adjustable design
- > Versatile thanks to alternative installation using slot nuts or threaded shaft holder
- > Slot nuts and mounting screws for installation on FIPA SLine and MLine extrusions included in scope of delivery

Technical data

| Item no. | Weight [g] | Air nippers |
|------------|------------|-------------|
| GT-NR10ST2 | 116 | GT-NR10L |
| GT-NR20ST2 | 119 | GT-NR20 |
| GT-NR30ST2 | 125 | GT-NR30 |
| GT-NR50ST2 | 165 | GT-NR50 |

Dimensions

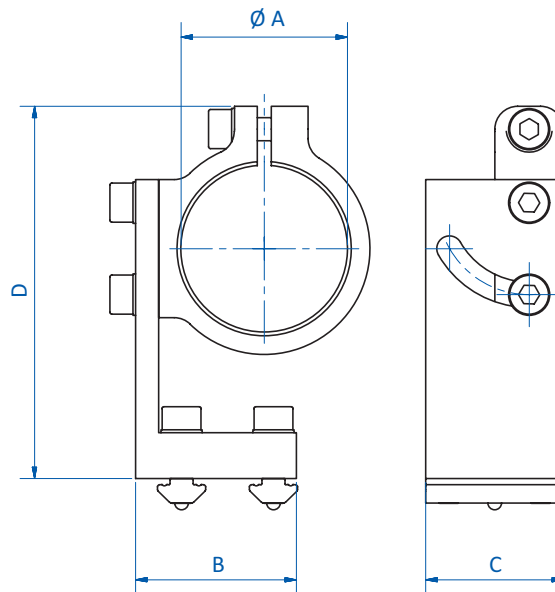

| Item no. | Ø A [mm] | B [mm] | C [mm] | D [mm] |
|------------|----------|--------|--------|--------|
| GT-NR10ST2 | 36 | 35 | 30 | 81 |
| GT-NR20ST2 | 45 | 35 | 30 | 87.5 |
| GT-NR30ST2 | 56 | 35 | 30 | 90.5 |
| GT-NR50ST2 | 75 | 35 | 30 | 109.5 |