

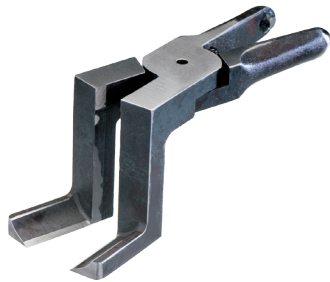

# Nipper technology | Air nippers – manual and automatic operation

Singular blades for plastic, Z-shape

## Singular blades for plastic, Z-shape



### Product notes

- > Blades with offset cutting edge for overcoming obstacles or for narrow sprues

### Technical data

Item no.	Material	Max. cutting thickness [mm]		Weight [g]	Air nippers
		PP/PE	ABS		
<b>N20AH</b>	Ferrous alloy	7	5	240	GT-N20 GT-NR20 GT-NS20
<b>N30AH</b>	Ferrous alloy	10	6.5	450	GT-N30 GT-NR30 GT-NS30

### Dimensions

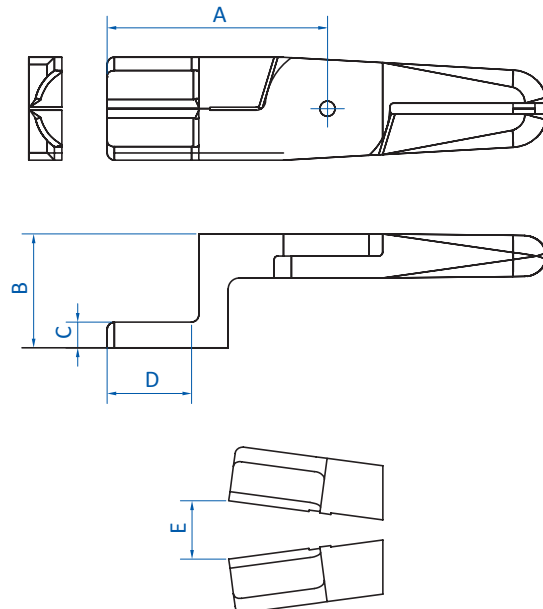

Item no.	A [mm]	B [mm]	C [mm]	D [mm]	E [mm]
<b>N20AH</b>	60	31	7	23	16
<b>N30AH</b>	80	65	8	34	22