

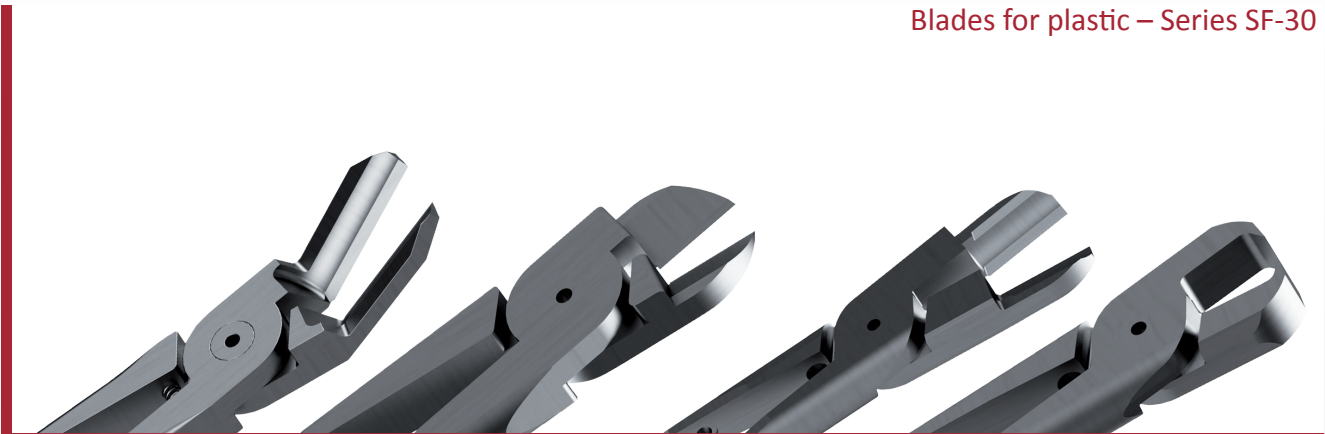

### Blades for plastic – Series SF-30



#### Product notes

- > Forged blades from high alloy steel and heat surface treated
- > Suitable for all nippers of the size 30

#### Technical data

Item no.	Plug design	Max. opening width [mm]	Max. sprue diameter [mm]	Material	Weight [g]	Air nippers
<b>SF30.A30.76</b>	30° angle	18.5	9	Ferrous alloy	378	GT-N30 GT-NR30 GT-NS30
<b>SF30.I53</b>	Inline	12.5	9	Ferrous alloy	365	GT-N30 GT-NR30 GT-NS30
<b>SF30.I74</b>	Inline	19	9	Ferrous alloy	464	GT-N30 GT-NR30 GT-NS30
<b>SF30.P45</b>	Perpendicular	10	9	Ferrous alloy	374	GT-N30 GT-NR30 GT-NS30

#### Dimensions

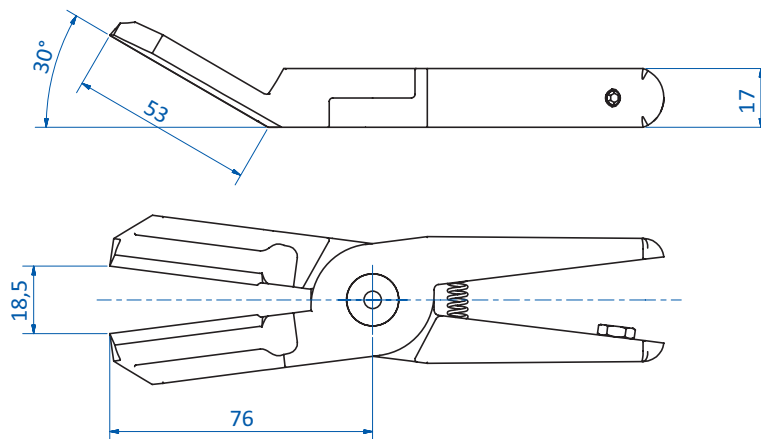

SF30.A30.76



# Nipper technology | Air nippers – manual and automatic operation

Blades for plastic – Series SF-30

## Dimensions

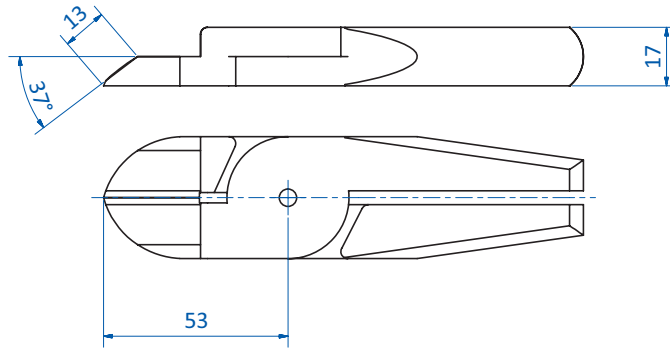

SF30.I53

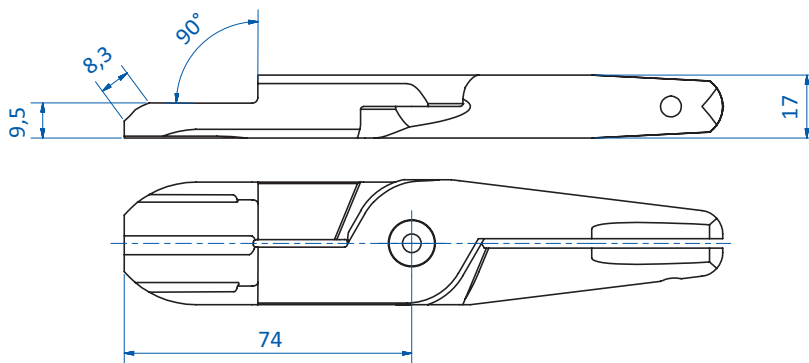

SF30.I74

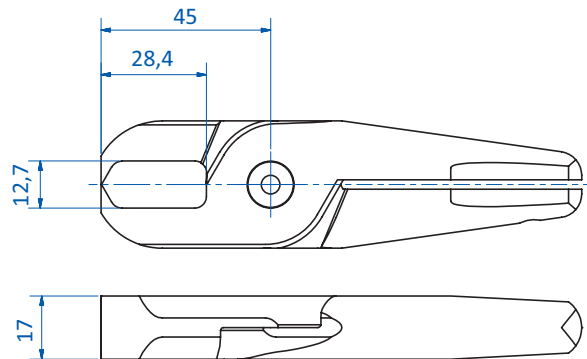

SF30.P45