



Quick-change systems | R Series

Quick-change systems rectangle, gripper side

Quick-change systems rectangle, gripper side

COMPATIBLE WITH STAR SYSTEMS

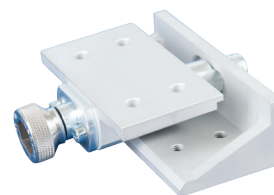

Product notes

- > Manual interface between robot and gripper system
- > Minimized downtime due to fast gripper change
- > Robot side not included in scope of delivery

Technical data

Item no.	Lifting force [N]	Weight [g]	Suitable robot side
GR05.122	150	171	GR05.121

Dimensions

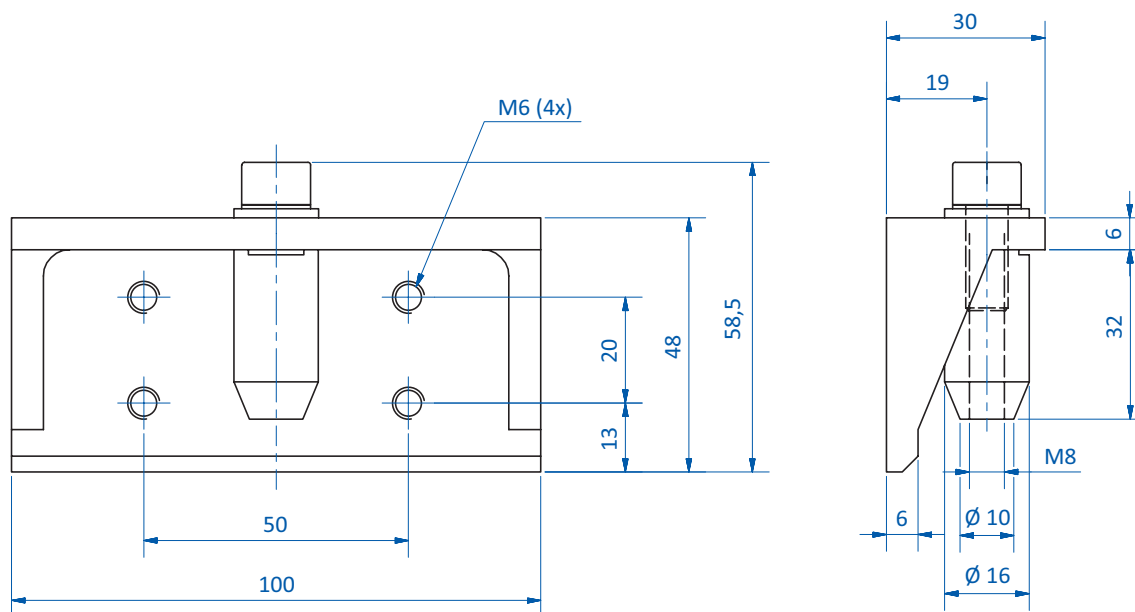



Dimensions for quick-change system robot side incl. gripper side

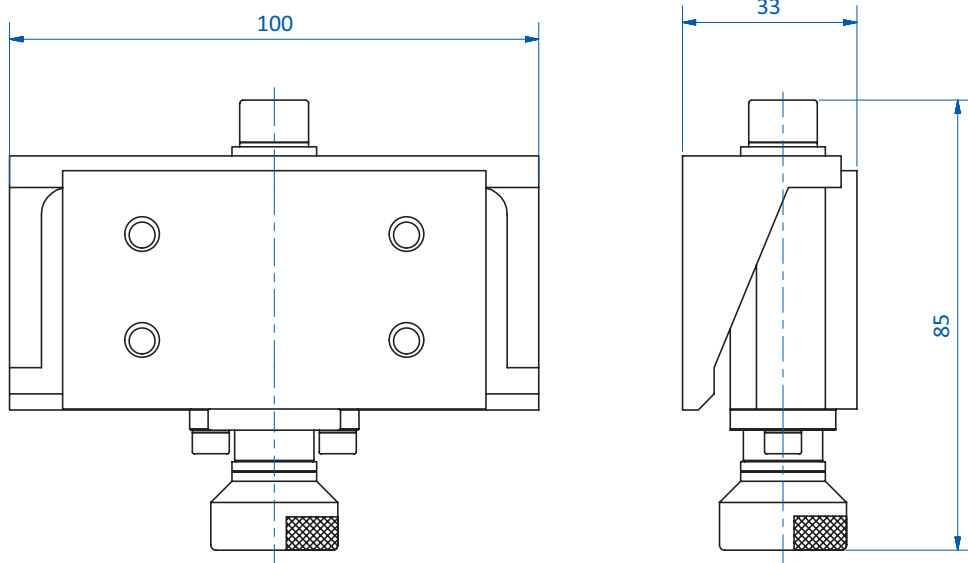



Quick-change systems rectangle, robot side

COMPATIBLE WITH STAR SYSTEMS

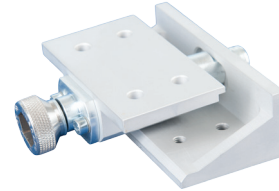
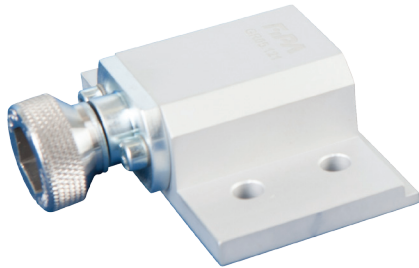

Product notes

- > Manual interface between robot and gripper system
- > Minimized downtime due to fast gripper change
- > Gripper side not included in scope of delivery

Technical data

Item no.	Lifting force [N]	Weight [g]	Suitable gripper side
GR05.121	150	168	GR05.122

Dimensions

