



Series 100 – sprue grippers, clamping diameter 10 mm – double-acting



Product notes

- > Grippers with wide jaw opening for large gates
- > Gap-free closing for flat gates
- > Dual-action for short cycle times; opening and closing separately controllable
- > Housings and gripper jaws consist of an anodized, high-strength aluminum alloy
- > Spring-assisted opening
- > Double-acting
- > Medium: filtered and oiled/non-oiled air
- > Ambient air temperature: -20°C to +80°C (-4 °F to 176 °F)

Technical data

Item no.	Jaw	Operating pressure [bar (psi)]	Sensor	Closing force at 6 bar (87 psi) [N]	Weight [g]
GR04.102	Standard	2.5 - 8 (36.3 - 116)	without	20	51

Dimensions

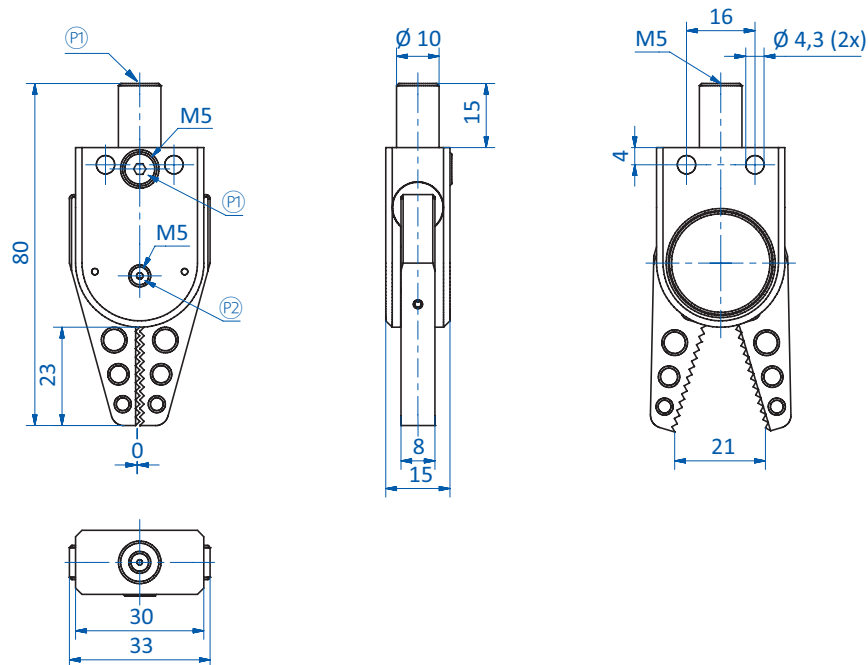

Ⓟ = Compressed air supply (close) Ⓠ = Compressed air supply (open)