



# Extrusion systems | Special elements

Pneumatic centering units, single acting

## Pneumatic centering units, single acting



**STRONG HOLDING FORCE**

### Product notes

- > Single-acting centering element for docking with the mold
- > Use for locking the gripper in place while placing inserts or demolding with high force
- > Optional Sensors can be used to detect locking and/or unlocking
- > Bushing can be mounted from either side in the mold

### Technical data

Item no.	Suitable guiding sleeve	Clamping $\varnothing$ [mm]	Holding force at 6 bar (87 psi) [N]	Accessories
<b>GR07.520-14</b>	GR07.521-14	14	400	Sensor: GR04.198 Sensor: GR04.198/NPN Sensor mounting bracket: GR04.038S
<b>GR07.520</b>	GR07.521	20	750	Sensor: GR04.198 Sensor: GR04.198/NPN Sensor mounting bracket: GR07.520S



## Dimensions

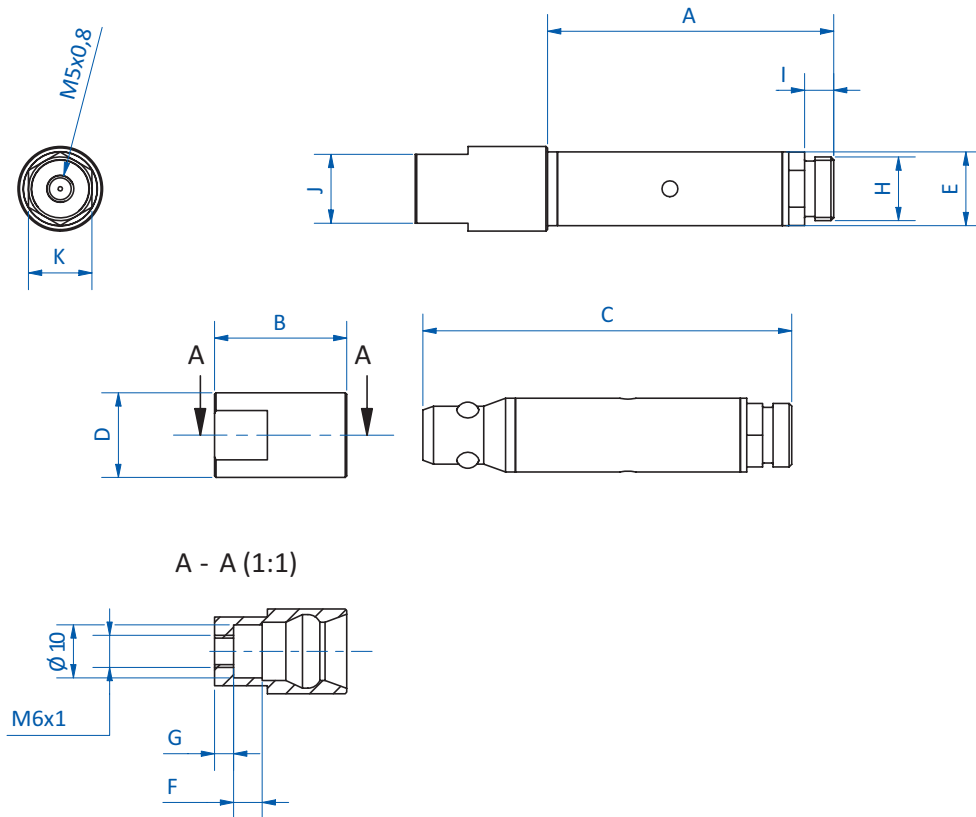

Item no.	A [mm]	B [mm]	C [mm]	Ø D [mm]	E [mm]	F [mm]	G [mm]	H	I [mm]	J [mm]	K [mm]
<b>GR07.520-14</b>	54	25	70	16	14	5.4	4	M12	5.5	13	12
<b>GR07.520</b>	75	33	96	26	20	5.4	4.6	M17	8	--	17