



Series | Oval vacuum cups SO

High temperature HNBR oval cups – SKH-O

High temperature HNBR oval cups – SKH-O

UP TO 160 °C (320 °F) & MINIMUM MARKING



Product description

Oval vacuum cups for smooth surfaces suitable for removing hot plastic parts to be painted from an injection molding machine. Connection via plug-in nipple.

Advantage

- > Free of silicone and other paint-wetting-impairment substances (PWIS)
- > Minimum-marking
- > Significantly increased suction force compared to round vacuum cups of the same width
- > Soft sealing lip also allows adhesion to curved products

Ordering notes:

From size 15x5 mm upward, a gripper clamp (available separately) is recommended to prevent inadvertent rotation

Technical data

Item no.	Model / Lip dimensions		Material / Colour	Usage temperature [°C (°F)]
132.4x2.031.*	SKH-O-4x2A	0.5	HNBR (ge)	0 - 160 (32 - 320)
132.7x4.034.*	SKH-O-7x4	0.8	HNBR (ge)	0 - 160 (32 - 320)
132.15x5.067.*	SKH-O-15x5	1	HNBR (ge)	--
132.24x8.066.*	SKH-O-24x8	1	HNBR (ge)	--
132.36x12.068.*	SKH-O-36x12	2	HNBR (ge)	--
132.45x15.064.*	SKH-O-45x15	3	HNBR (ge)	--

Accessories

Clamp:

--
--
78.030
78.032
78.032
78.033

Accessories

Item no.	 Suitable fittings					
	M3-male	M4-male	M5-male	G1/8-male	G1/4-male	G1/4-female
132.4x2.031.*	270.014	270.111	270.300	--	--	--
132.7x4.034.*	270.014	270.111	270.300	--	--	--
132.15x5.067.*	--	--	--	270.431	--	--
132.24x8.066.*	--	--	--	270.431	--	--
132.36x12.068.*	--	--	--	270.431	--	--
132.45x15.064.*	--	--	--	--	270.097	270.098

* When ordering please add the appropriate material code to item no. You will find it on www.fipa.com.



Dimensions

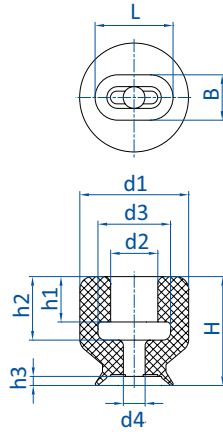

Drawing A

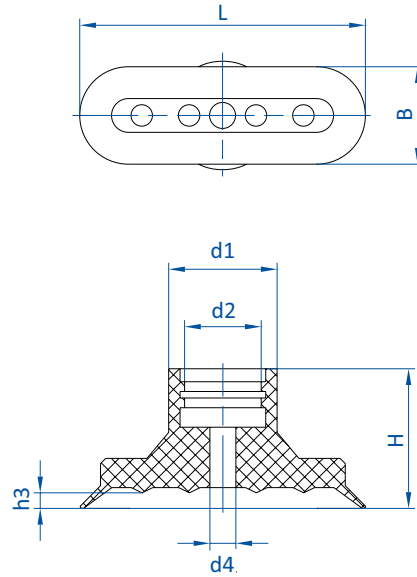

Drawing B

Item no.	Drawing	L [mm]	B [mm]	Ø d1 [mm]	Ø d2 [mm]	Ø d3 [mm]	Ø d4 [mm]	H [mm]	h1 [mm]	h2 [mm]	h3 [mm]
132.4x2.031._*	A	4.3	2.5	6	2.6	4	1.2	6	2.5	3.5	0.5
132.7x4.034._*	A	7.5	4	6	2.4	3	1.4	6	2.3	3	0.7
132.15x5.067._*	B	15	5	9	5	--	2	12	--	--	0.8
132.24x8.066._*	B	24	8.5	12.5	5	--	3	13	--	--	1.5
132.36x12.068._*	B	36	12	12	5	--	4	12	--	--	1.6
132.45x15.064._*	B	44	15	16.5	12	--	4	22	--	--	2.4

* When ordering please add the appropriate material code to item no. You will find it on www.fipa.com.