



Electric plug connectors for SR50, SR90 and SR150



Product notes

- > Electrical interface between robot and gripper
- > 9 pin SUB-D plug and 15 pin SUB-D plug
- > Max. cable cross section 0.14 mm² based on 16 - 18-wire cable
- > Order connectors separately D-SUB 25 (male): 20.505
- > 20.537 and 20.538: with pre-assembled and soldered cable

Technical data

Item no.	Suitable quick-change systems	Type	Number of pins	Operating voltage [VDC]	Weight [g]	Suitable plug
20.535	SR90-A, SR150-A, SR90-A-SL, SR150-A-SL, SR90-A-SL-MV	female (robot)	15	24	42	20.505
20.536	SR90-B, SR150-B	male (gripper)	15	24	41	20.505
20.537	SR50-A, SR50-A-SL, SR50-A-MV, SR50-A-SL-MV	female (robot)	9	24	42	20.505
20.538	SR50-B	male (gripper)	9	24	41	20.505

Wiring diagram for 20.537

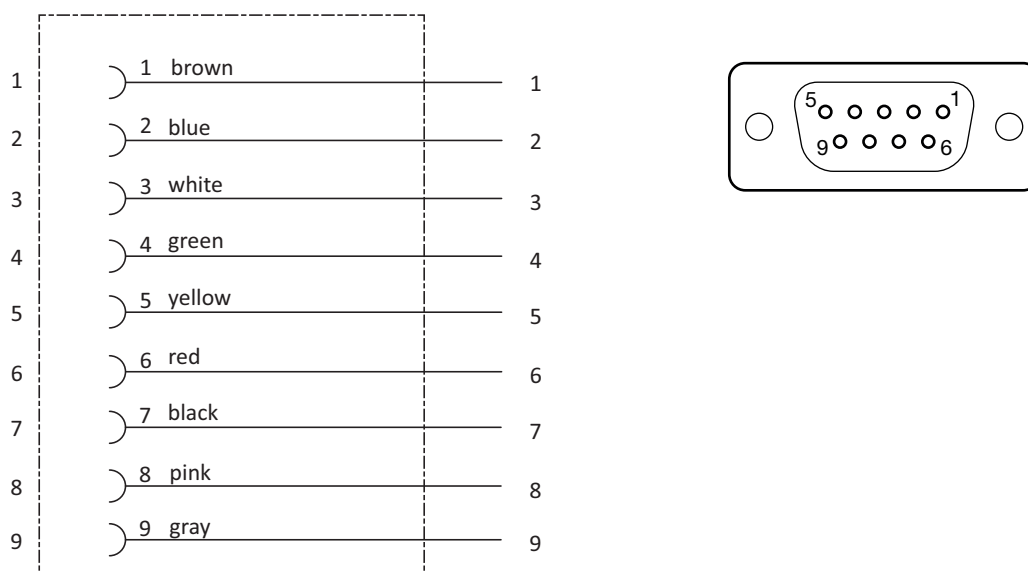



Wiring diagram for 20.538

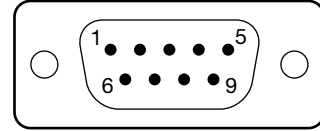
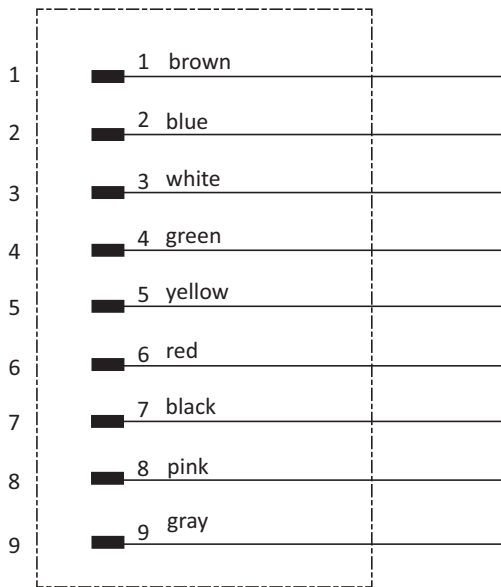

Application example: SR Series with electric connectors 20.536



Dimensions

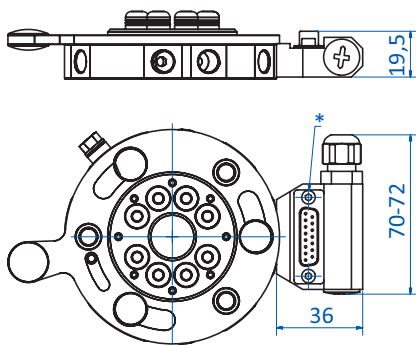

20.535 | 20.536

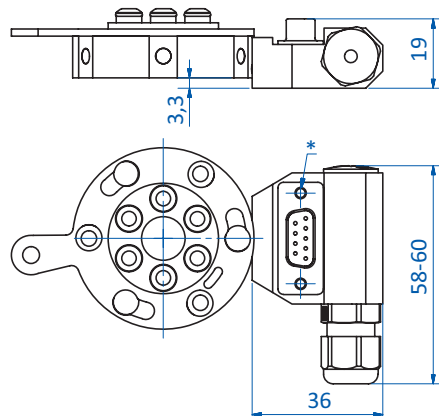

20.537 | 20.538

* = Remove plug connection for cable installation