

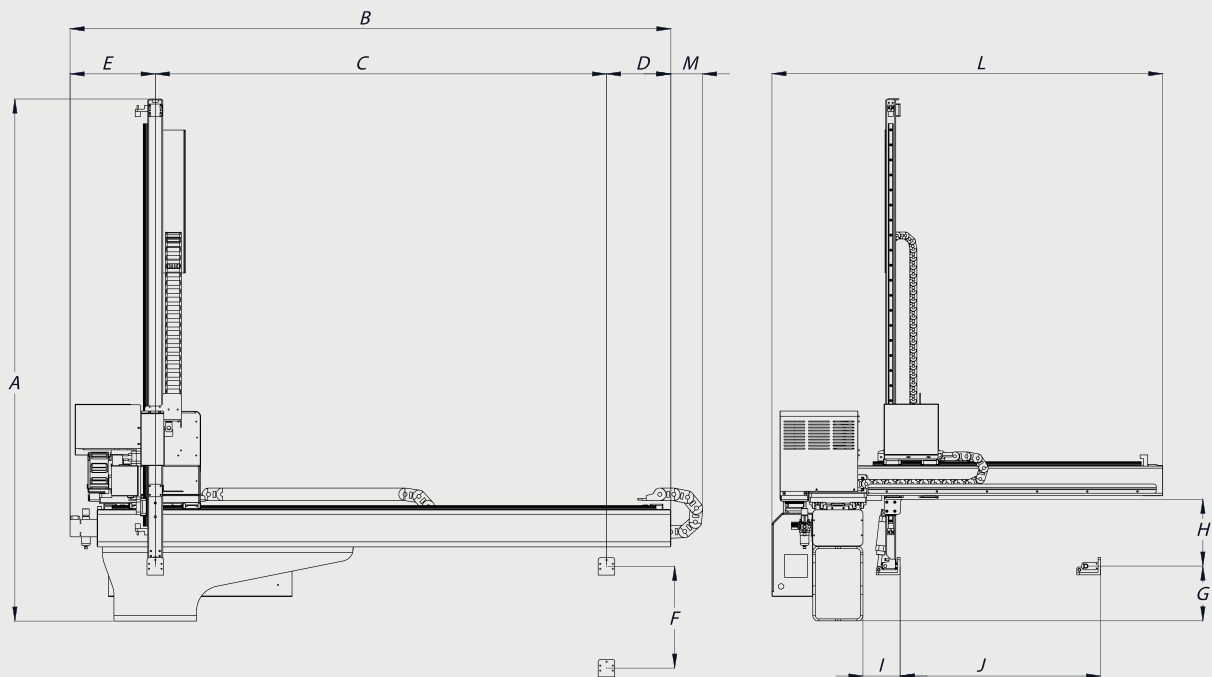

► FUNDAMENTAL MECHANICAL SPECIFICATIONS

Model	Axis Strokes (mm)			Injection Clamping Force Range (Ton)	Driving Method	Lineer Position Repeatability (mm)	C Axis Posture ↘ 90°		Net Weight (kg)
	Vertical	Crosswise	Traverse				Maximum Payload (kg)	C Axis Posture Torque (Nm)	Main Body
eMW1000	1000	660	1500	100 - 380	AC Servo Motor	±0.1	(*) 6	25	280

(*) Weight of Robotic Hand is Included.



► DIMENSIONS (mm)

A	Height	1885	G	Vertical Wait	215
B	Length	2100	H	Gripper Assembly Position under Crosswise Axis	265
C	Traverse Axis Stroke	1500	I	Minimum Crosswise Wait	150
D	Traverse Axis Stroke Excluded Distance (Product Place Region)	260	J	Maximum Crosswise Stroke	660
E	Traverse Axis Stroke Excluded Distance (Product Pick Up Region)	340	I+J	Maximum Crosswise Reach	810
F	Vertical Axis Stroke	1000	L	Width	1420
M	Traverse Axis Cable Carrier Overflow	130			

Power Supply	Maximum Power (kW)	Air Pressure (Bar)	Air Consumption (NI/Cycle)
Three-phase AC 380V ± %10 (50Hz/60 Hz)	1.3	4 - 6 (*2)	3.5

(*2) Need for Pressurized Air Purified (Dried) from Oil and Humidity Exists.

► GENERAL FEATURES

- Vacuum Line
- Blow Line
- Sprue Gripper Line
- Product Pickup from Fixed and Moving Platens
- Selection of Operator / Non-operator Working Direction
- Vacuum Level Adjustment on the Control Panel
- Product Sorting and Stacking
- Product Sorting in Matrix Form
- Soft Sorting / Separation
- Y Axis Free
- Eco Mode (Automatic Energy Saving Cycle Feature)
- Product Extraction from Core in the Mold
- Sprue Separation
- Sample Separation
- Crosswise J (Pass) Motion
- Defective Product Separation (Machine Feature Compatibility Support)
- Message Support on the Control Panel
- IMM Door Open Permission during Pause
- Pause during Operation
- C Axis Rotation Control
- 90° Soft Stop
- Connection Adapter between Robot and Injection Machine
- Mode Operation Function Control
- Extra Mold Safety Sensor (Optional)
- Overload Protection
- Conveyor Control
- Multi Language Support
- Operation Record Feature
- Alarm Record Feature
- USB Memory Connection
- Memory of upto 50 Molds
- Ejector Control
- Euromap 12/67 Robot Interface
- Economic Vacuum Feature (Optional)