



Telescopic
Vertical
Axis



Vertical Axis
Balance
Cylinder



Manual
Central
Lubrication



Easy Position
(Location)
Teaching



Fast
Cycle

FUNDAMENTAL MECHANICAL SPECIFICATIONS

Model	Axis Strokes (mm)			Injection Clamping Force Range (Ton)	Driving Method	Lineer Position Repeatability (mm)	C Axis Posture ↘ 90°		Net Weight (kg)
	Vertical	Crosswise	Traverse				Maximum Payload (kg)	C Axis Posture Torque (Nm)	Main Body
MW1800II	1800	1300	2500 [3000]	650 - 1300	AC Servo Motor	±0.1	(*) 25	65	656 [690]

(*1) Weight of Robotic Hand is Included.

([]) Optional Dimensions.

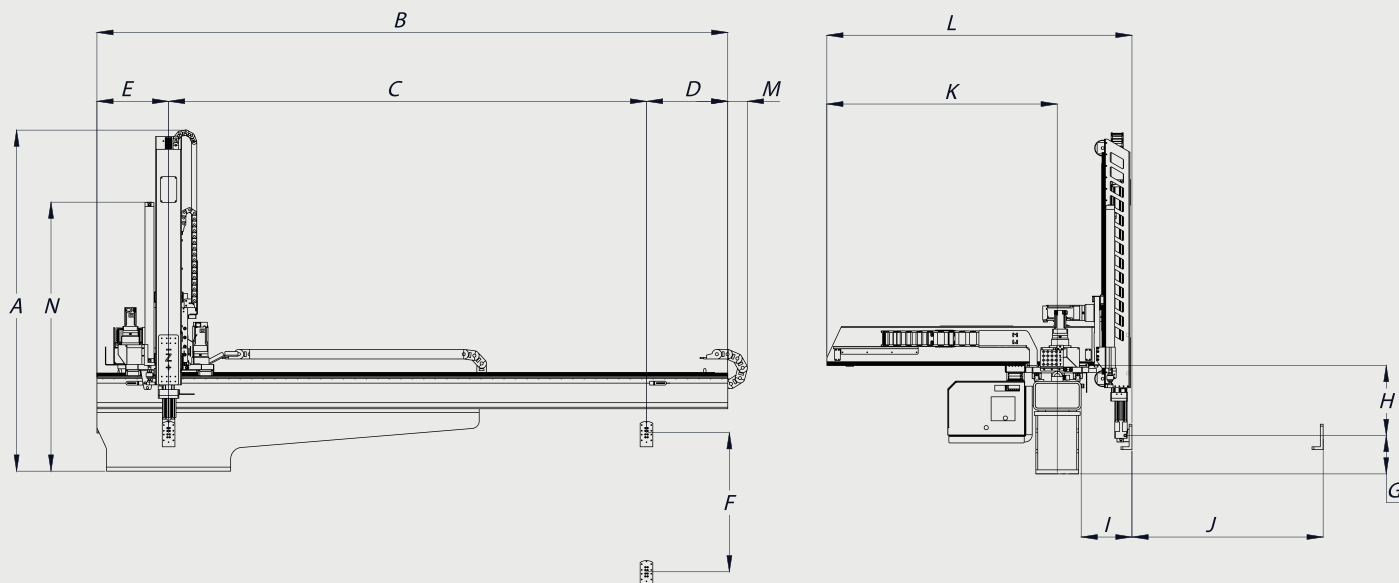

DIMENSIONS (mm)

A	Height	2060
B	Length	3300 - [3800]
C	Traverse Axis Stroke	2500 - [3000]
D	Traverse Axis Stroke Excluded Distance (Product Place Region)	425
E	Traverse Axis Stroke Excluded Distance (Product Pick Up Region)	375
F	Vertical Axis Stroke	1800
M	Traverse Axis Cable Carrier Overflow	100
N	Balance Cylinder Height	1607

G	Vertical Wait	200
H	Gripper Assembly Position under Crosswise Axis	366
I	Minimum Crosswise Wait	266
J	Maximum Crosswise Stroke	1300
I+J	Maximum Crosswise Reach	1566
L	Width	1900
K	Crosswise Start Distance	1503

Power Supply	Maximum Power (kW)	Air Pressure (Bar)	Air Consumption (NI/Cycle)
Three-phase AC 380V ± %10 (50Hz/60 Hz)	1.9	(*) 4 - 6	13.0 [26.0]

(*2) Need for Pressurized Air Purified (Dried) from Oil and Humidity Exists.

([]) Optional Dimensions.

GENERAL FEATURES

- Vacuum Line
- Blow Line
- Sprue Gripper Line
- Product Pickup from Fixed and Moving Platens
- Selection of Operator / Non-operator Working Direction
- Vacuum Level Adjustment on the Control Panel
- Product Sorting and Stacking
- Product Sorting in Matrix Form
- Soft Sorting / Separation
- Y Axis Free
- Eco Mode (Automatic Energy Saving Cycle Feature)
- Product Extraction from Core in the Mold
- Sprue Separation
- Sample Separation
- Crosswise J (Pass) Motion
- Defective Product Separation (Machine Feature Compatibility Support)
- Message Support on the Control Panel
- IMM Door Open Permission during Pause
- Pause during Operation
- C Axis Rotation Control
- 90° Soft Stop
- Connection Adapter between Robot and Injection Machine
- Mode Operation Function Control
- Extra Mold Safety Sensor (Optional)
- Overload Protection
- Conveyor Control
- Multi Language Support
- Operation Record Feature
- Alarm Record Feature
- USB Memory Connection
- Memory of upto 999 Molds
- Ejector Control
- Euromap 12/67 Robot Interface
- Economic Vacuum Feature (Optional)