



## Round quick-changers $\varnothing$ 150 mm, 10 air inlets – gripper side



### Product notes

- > Manual interface between robot and gripper system
- > Air connections always correctly aligned
- > Body made of anodized aluminum alloy

### Technical data

<b>Item no.</b>	<b>SR150-B-2</b>
<b>Number of pneumatic connections</b>	10xG1/8
<b>Working pressure [bar (psi)]</b>	0 - 6 (0 - 87)
<b>Max. axial force F [N]</b>	1,000
<b>Max. torque Mt [Nm]</b>	250
<b>Max. torque Mb [Nm]</b>	100
<b>Max. recommended handling weight [kg]</b>	40
<b>Weight [g]</b>	850
<b>Suitable electrical connectors</b>	20.536

### Lifting force / torque

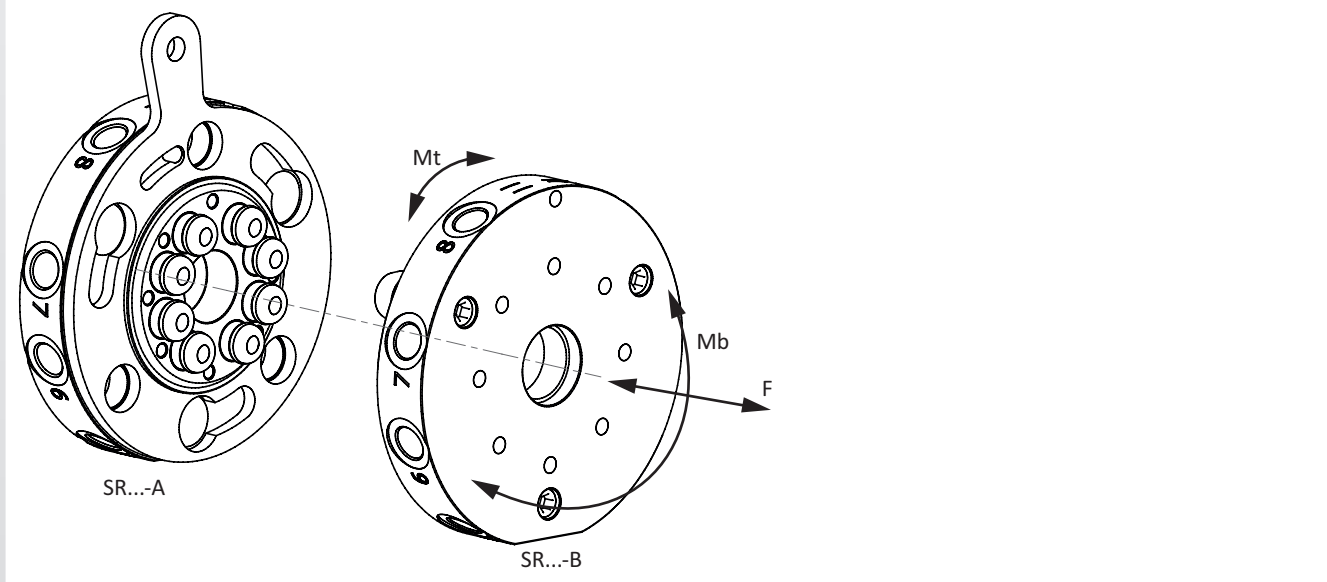



# Quick-change systems | SR Series

Round quick-changers  $\varnothing$  150 mm, 10 air inlets – gripper side

## Dimensions

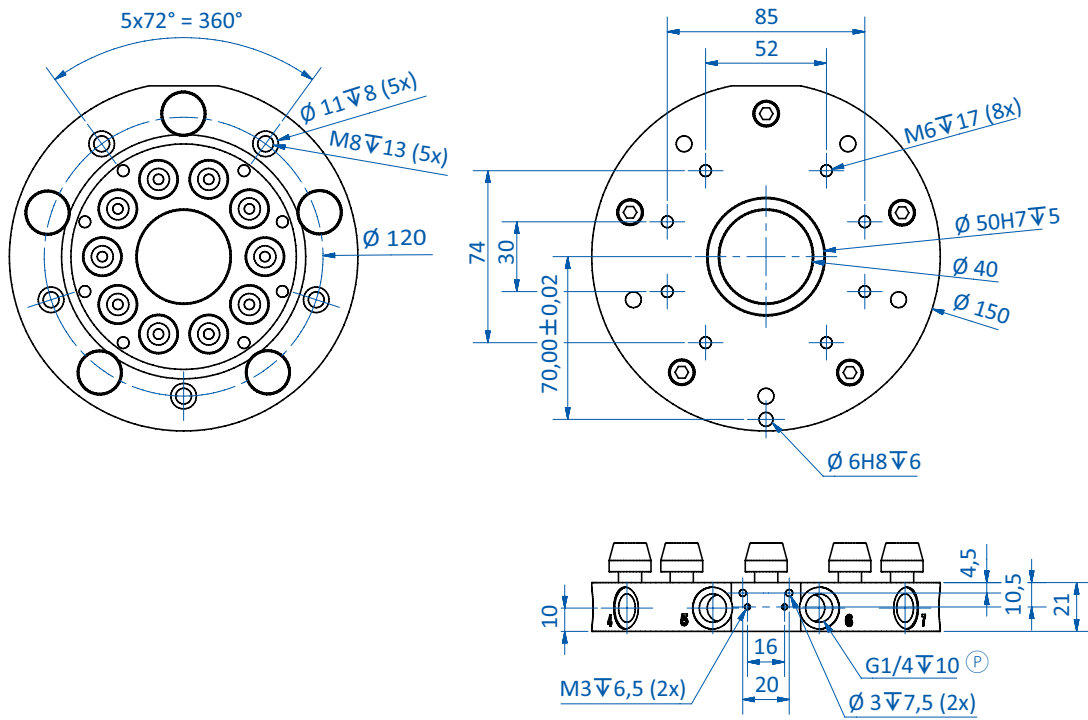

Ⓟ = Pneumatic connection