



# EVERYTHING FROM ONE SOURCE

Advice – Planning – Realisation



vacuum • gripping • lifting

**FIPA**

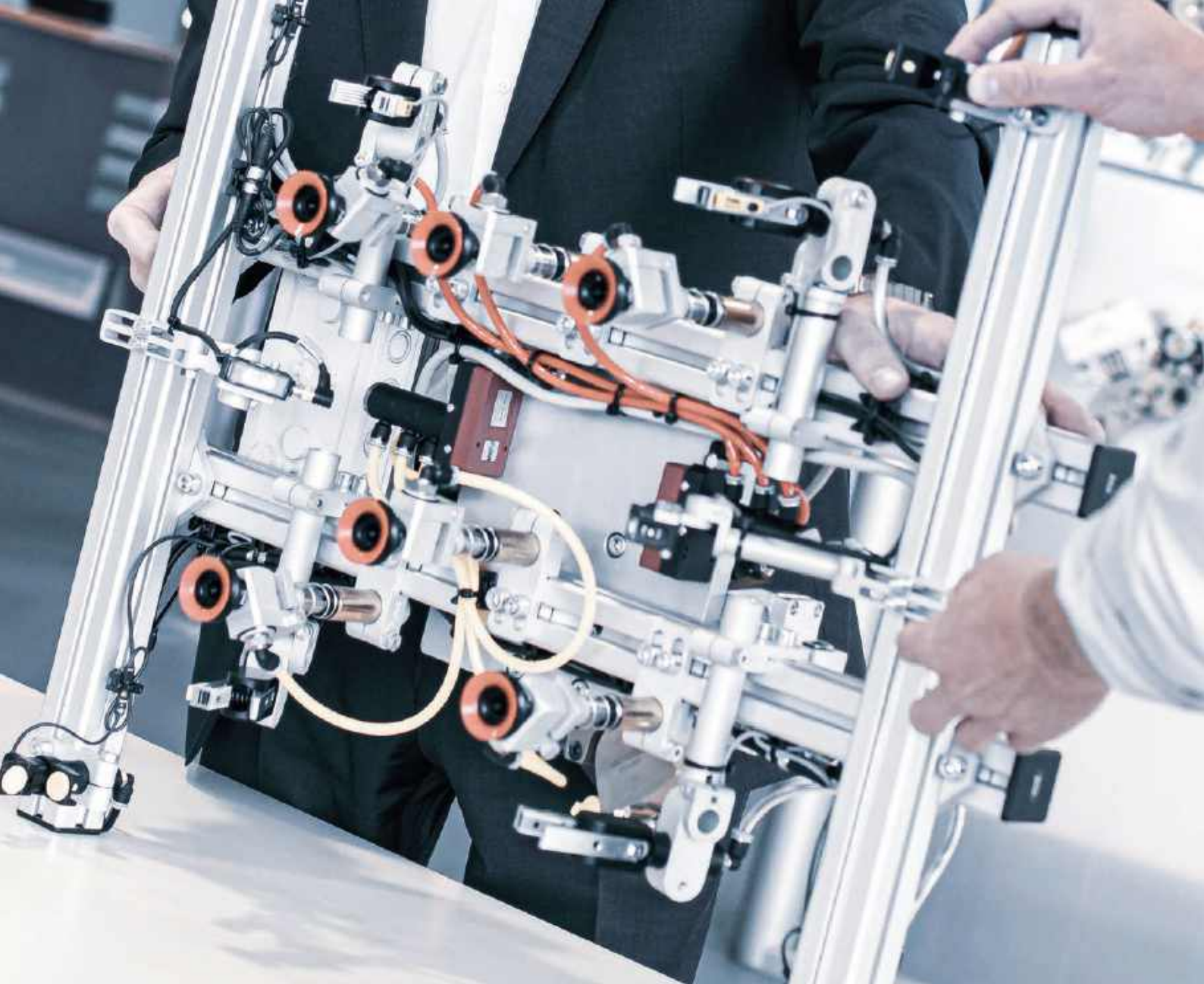

About us 3

---

End-of-Arm-Tooling 6

---

Vacuum cups 16

---

Area grippers 28

---

Vacuum components 30

---

Ergonomic Handling 38

---

Imprint 43

---

# AUTOMATION SOLUTIONS ACCORDING TO **YOUR** NEEDS

We are your global partner for all requirements in the industrial automation industry. Thanks to our many years of experience, reliability and flexibility, we always find the right solution to maximise your process reliability.

Production and logistics mean movement. In most industries, products are picked up, held, deposited, turned, turned over, positioned and lifted.

Vacuum technology can be used to move workpieces safely and quickly, but above all to handle them gently and without causing damage. We have a comprehensive range of innovative and high-quality products for all these applications. With our customer-specific solutions, you can optimise your production processes while supporting your employees in their daily work.

## **Are you looking for an automation approach and want to improve your processes?**

We are more than just a supplier of components. With our expertise, application know-how and professional project management, we provide the optimum solution for your handling task in vacuum, gripping and lifting technology.

## **Do you want to increase efficiency and productivity at the same time as working ergonomically?**

We work closely with our customers and therefore always find an answer - from standard solutions to customised designs of the gripper construction.

Our goal: to optimise processes in production and logistics with individual components and customised solutions.

Personal contact, fast response times and expertise are our path to successful projects. We are active for you worldwide through our large partner network.

We keep moving for **you** so that production and logistics run reliably and smoothly.

# WE MOVE

With know-how, expertise, flexibility and professional project management, we guide you to the best solution for your handling task in vacuum, gripping and lifting technology.



## Box

Efficient handling and transportation of cardboard packaging in storage and shipping areas.



## Injection molded parts

Low-marking removal of hot plastic parts, cutting of sprues.



## Sacks

Ergonomic, safe handling and picking of sacks.



## Bags/Pouches

Handling of unstable flowpacks and bags with different textures.



## Sheet metal

Fast cycling times and high process reliability for sheet metal transfer, body car handling and machine loading.



## Wood

Handling of wooden elements with different surfaces, machine loading.



## Glass/bottles

Non-marking, safe handling and assembly of panes, glass and window elements.



## Paper/foils

Precise and reliable handling without soaking in the product.



## Drums

Safe handling of heavy drums, buckets and canisters.



## Food

Flexible and FDA-compliant handling for direct contact with food.



## Pallets

Easy and safe handling of pallets for a smooth material flow.



## Electronic parts

Clean and flexible handling of very small components with maximum precision.

# COMPETENCE IN GRIPPER CONSTRUCTION

Three different paths lead to your customised gripper system.  
Choose the right one for you from the three versions on offer.



## Advice

---

- You get advice from our experts
- You take over the planning and construction of the gripper system yourself
- We supply all required gripper elements
- You benefit from our many years of experience and competence
- Our extensive product range reduces your procurement costs



## Advice + Planning

---

- We take over the detailed planning with 3D-CAD
- We supply all components and detailed assembly instructions
- Customer support throughout the entire project duration and beyond
- The gripper system is assembled by yourself



## Advice + Planning + Realisation

---

- We design according to your requirements
- We implement the complete gripper system according to your specifications
- The system is delivered fully assembled, tested and preset
- Commissioning and fine adjustment on site



## END-OF-ARM-TOOLING

Benefit from our innovative programme of End-of-Arm-Tooling components.

The range includes a comprehensive, modular gripper construction kit with gripping and fastening elements as well as a wide range of accessories - specially tailored to your particular application.

You can find a wide range of gripper technology products online at [www.fipa.com](http://www.fipa.com) or in the digital product catalogue.

- Quick-change systems
- Extrusion and Mounting elements
- Sprue grippers
- Parallel and Angular grippers
- Gripper fingers
- ID grippers
- Needle grippers
- Magnetic grippers
- Nipper technology
- Linear technology
- Sensors and Signal processing



# RELIABLE PROCESS HANDLING

Our modular gripper system consists of a large number of compatible, high-quality automation components whose perfect interaction determines the reliability and productivity of your system.

We support you with durable standard components. In addition, we also offer the option of implementing customised special solutions.



## ACTUATORS FOR FIXING THE WORKPIECE

- ID gripper
- Parallel gripper
- Sprue gripper
- Vacuum cups

## MOUNTING ELEMENTS FOR POSITIONING THE ACTUATORS

- Extrusions
- Profile connectors
- Clamps
- Gripper arms

## INTERFACE TO THE ROBOT

- Quick-change system

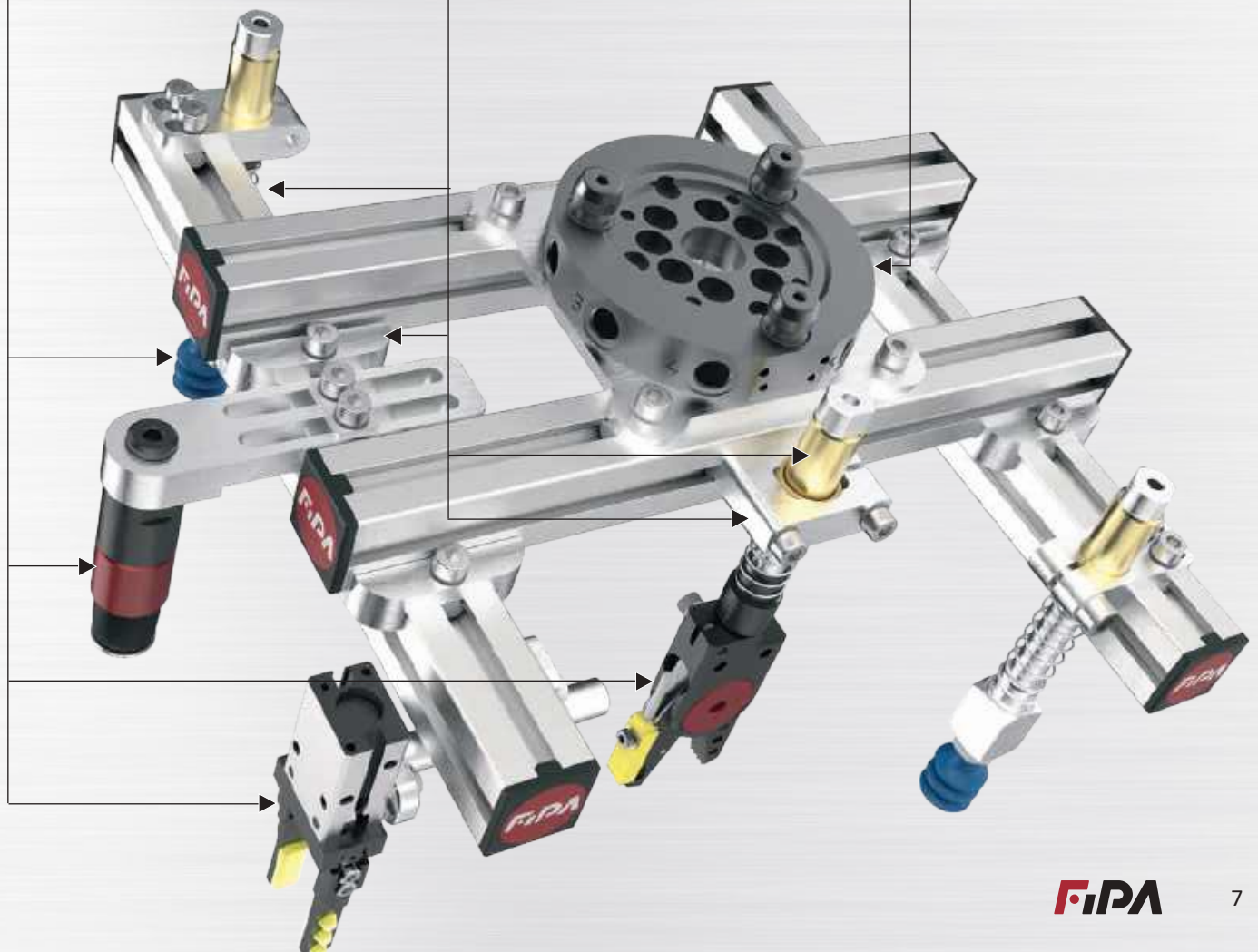

## QUICK-CHANGE SYSTEMS

Interface to the robot

- Series S - square
- SR series - round, optionally with SAFE-LOCK and valves
- MPS series - for automatic mould change
- In standardised sizes for common industrial robot flanges



## Gripper arms

Mounting and integrating vacuum and gripper components in gripper systems

- Spring-loaded models with anti-twist protection ensure gentle and reliable handling of the workpiece
- Spring-loaded versions absorb the stroke during the ejection movement of the injection moulding machine
- Gripper arms in rigid and swivelling versions available
- Clamping diameters 10, 14, 20 and 30 mm





## Extrusions

The base for gripper systems

- Aluminium profiles
- Special lengths over 2,000 mm on request
- Low weight, high stability
- Standard groove sizes and shapes



## Profile connectors

Ensure solid holding

- Fixed connection of two profile sections
- Cross connector for 90° connection of profiles
- Variable angle connectors with fixed or adjustable angle available



## Angle clamps

Flexible mounting options for actuators in gripper systems

- For connecting gripper arms
- Various versions and clamping diameters available
- Versions with selectable angle adjustment available



## Sprue grippers

The industry standard for gripping sprues

- Various gripper sizes for any space conditions and gripping forces
- Wide range of different jaw shapes and materials
- Optionally with direct or indirect sensor monitoring
- Housing and gripper jaws made of anodised, high-strength aluminium alloy



Series 60  
Miniature gripper

## Power grippers

With a very high closing force

- For demoulding large components
- With and without stroke
- Various jaw shapes and materials
- Optionally with direct sensor monitoring



Power gripper  
without stroke  
Series 332

## Grippers for direct mounting

Space-saving mounting

- Single and double-acting versions
- Gap-free closing for secure gripping of small or flat sprues
- Optionally with direct or indirect sensor monitoring



## 3-finger, parallel and angular grippers

Accurately positioned gripping, lifting and depositing of components

- 2-finger parallel gripper - the all-round talent for internal and external gripping of workpieces
- 3-finger parallel gripper for precise handling of round components
- Angular grippers for gripping on undercuts or for clamping components
- Single-acting and for short cycle times double-acting versions available



## Gripper fingers

Removal of complex components with undercuts

- 35° and 95° angle stroke
- Single-action with return spring
- Gentle gripping with HNBR elastomer pads
- Housing and jaws made of an anodised aluminium alloy



## Compact gripper fingers

Gentle clamping of workpieces

- Wide range of contact materials: HNBR, NBR, FKM, silicone
- Simple replacement of the elastomers
- Position monitoring with sensor possible



## ID grippers

For gripping workpieces with holes and recesses with an expanding elastomer gripper

- Compact design
- Gripper heads in 3-10 mm available in food-safe materials
- High holding force
- Elastomer bellows made of EPDM or silicone
- Simple and non-destructive change of the gripper heads or of the elastomer bellows



## Needle grippers

Handling of dimensionally unstable goods, such as fabric

- Control via compressed air
- Double-acting for short cycle times
- Optional monitoring of the piston position
- Versions with customisable penetration depth of the needles



## Magnetic grippers

Handling of ferromagnetic workpieces

- Powerful permanent magnets with high holding force
- Handling without pneumatics
- Energy supply only necessary for depositing
- Holding the workpiece in the event of a power failure



## Air nippers

Separating and cutting of plastic sprues or metal wires

- A large selection of cutting inserts provide individual options for applications
- Integration directly into the gripper, into trimming stations or for manual actuation



Cutting inserts for plastic,  
L-shape



Cutting inserts for plastic,  
lateral cutting edge



Cutting inserts for plastic,  
Z-shape



Cutting inserts for plastic  
and metal, straight shape

## Linear technology

### Double-acting linear components

- Precise positioning of gripper components and vacuum cups possible
- Corresponding sensors for monitoring the operating position can be provided as an option

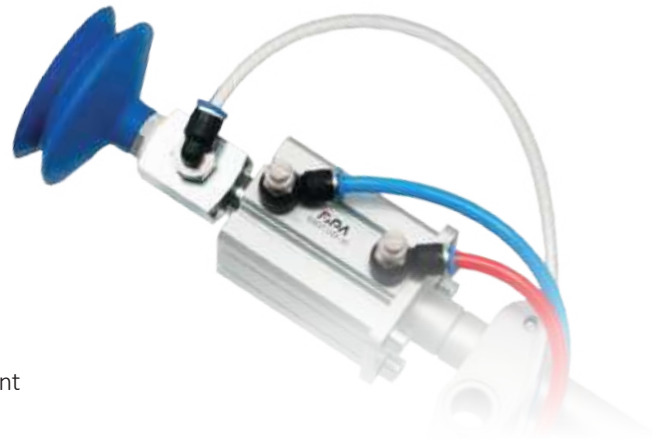

Double piston cylinder for moving the gripper component precisely to the workpiece

Short-stroke cylinder to compensate for the height difference



Guide carriages for the precise positioning of gripper elements

## Rotary units

### Process reliable thanks to optional position monitoring

- Versatile use thanks to adjustable rotation range from 0°-190°
- Compact installation due to centre feed-through for cables/tubes
- Extended service life of the rotating components thanks to optional shock absorbers
- Possible position monitoring with sensors



## Sensors

Component monitoring and monitoring of the operating position

- Magnetic-field and inductive sensors for active gripper elements, such as grippers, parallel grippers and gripper fingers
- Optical sensors for direct component inspection
- Wide range of cables and adapters available for signal forwarding



## Signal processing

As a link to the control unit



T-coupler  
with AND/OR logic link



Sensor relay switch box for bundling  
and logic linking (AND) of sensor  
signals, since signal inputs  
on the robot control system  
are usually limited



Signal converter M8 /  
signal inverter M8  
Conversion of sensor signals  
independently of the  
robot control system



## VACUUM CUPS

In the pick and place sector, all vacuum cups have the same task: lifting parts and moving them without causing damage. Different vacuum cups are used depending on the shape, size and material of the goods to be handled.

You can find the extensive range online at [www.fipa.com](http://www.fipa.com) or in the digital product catalogue.

- Flat vacuum cups
- Bellows vacuum cups
- Oval vacuum cups
- Bell shaped vacuum cups
- Bernoulli vacuum cup
- Lifting cylinders
- Spring levelers





## REPRESENTED IN MANY INDUSTRIES

- Wide range of vacuum cups: Flat vacuum cups for flat surfaces, bellows vacuum cups for sensitive and three-dimensionally shaped workpieces, oval vacuum cups for narrow components
- Lip diameters from 1 mm to 600 mm
- Numerous materials and special materials for a wide range of requirements
- Possible specific properties: PWIS-free, temperature-resistance, food suitability, wear-resistance, flexibility



### Plastic

- Temperature-resistant vacuum cups materials for removing hot plastic parts from the injection moulding machine
- Silicone- and PWIS-free, low-marking vacuum cups that enable subsequent painting of the products
- Excellent service life thanks to wear-resistant materials



### Sheet metal

- For the dynamic handling of sheet metal, preferably wear-resistant and oil-resistant materials are used
- Process-safe, slip-free handling thanks to „anti-slip“ support ribs
- Silicone- and PWIS-free, low-marking vacuum cups that enable subsequent painting of the products



### Packaging

- From handling packaged food to handling a wide variety of cardboard packaging
- Preferably wear-resistant vacuum cup materials that are elastic as well as flexible and have a long service life
- Fast, reliable pick and place when handling pouch packaging



### Food, paper, wood, glass and much more

- Use of low-marking, robust materials
- Rough and uneven surfaces are sealed without leaks
- High process reliability when handling and installing panes, glass and window elements
- FDA-compliant vacuum cups for the food industry

## Universal vacuum cups made of NBR and silicone

Various application possibilities

- NBR: wear-resistant and oil-resistant
- Silicone: adaptable, heat-resistant and usually FDA-approved



### Flat vacuum cups

- Flat product surfaces and sheet goods
- Positioning accuracy when depositing
- With and without support ribs



### Bellows vacuum cups

- 1.5 to 8.5 folds: the more folds, the greater the height and angle compensation
- Optimum adaptation to curved surfaces
- Vertical applications
- With and without support ribs



### Oval vacuum cups

- For elongated or cylindrical workpieces with limited space (e.g. mouldings, profiles, tubes, bolts)
- For curved workpieces and products with webs
- Offer a significantly higher suction force compared to round vacuum cups of the same width

## SP-BX series made of Varioflex® – the All-rounder

2K-Polyurethane – two different hardnesses in one vacuum cup

- Bellows vacuum cups with a very long service life
- Short cycle times thanks to stable body and quick resetting
- Excellent holding force on dry component surfaces



• **Dimensionally stable body**  
60° Shore A

• **Flexible, mark-free sealing lip**  
30° Shore A

Uneven and curved surfaces



Dry sheet metal



Processed or coated surfaces



Abrasive products



## SKT series made of Thermalon® – Handling of plastics

High-quality material mixture, up to 160 °C (360 °F)

- Flat, bellows and oval vacuum cups
- Mark-free material made of Thermalon®
- Free of paint-wetting-impairment substances (PWIS)
- Silicone-free
- High temperature-resistance
- Bellows vacuum cups also available with non-marking flock coating



**Flock coating**

Polyamide layer PA6.6 black



## SM series made of NBR – Dynamic handling of oily sheets

Anti-slip cleats

- Flat, bellows, oval and bell shaped vacuum cups
- Very high shear force absorption
- Long service life even when deployed in highly dynamic processes
- Short set-up times and maintenance intervals
- No slippage in the dynamic handling of metal sheets



• **Flexible sealing lip** for high holding forces even on curved sheets

• **Anti-slip** supports for absorbing lateral forces and preventing deformations



## SV-BG series made of 2K-Silicone – Film packaging

Handling of filled bags and a wide variety of film packaging

- Best possible sealing, even on bags with heavy creasing
- Ideal stability and hold with short cycle times and high acceleration
- 3.5 folds: Used for handling filled pouches
- 5.5 folds: Use for handling liquid or powdery filled bags
- 5.5 folds absorb shocks and vibrations and adapt perfectly to inclined surfaces
- Anti-intrusion protection prevents film from being drawn in



---

## SV-BGX series made of Varioflex® – Bag handling

Packaging industry, online business and logistics

- Allows low vacuum level (energy-saving)
- Flexibility also enables gripping of less filled bags
- Ideal stability and hold with short cycle times and high acceleration
- Wear-resistant material for a long service life



## SBV series made of Vinyl – Handling of packaging

Gripping flexible or curved goods

- Bellows and oval vacuum cups
- Long service life even in the case of abrasive product surfaces such as cardboard packaging
- Durable bellows vacuum cup with a long stroke
- Conformable sealing lip thanks to flexible material



## SV-TB series made of TPU – Handling cardboard packaging

Handling of cardboard packaging and flexible products

- Wear-resistant thermoplastic polyurethane
- 1.5 folds: Dynamic handling of cardboard packaging, e.g. in carton and tray erectors
- 2.5 folds: Large suction stroke enables palletising processes; dynamic handling of cardboard packaging and flexible products, e.g. filled cartons
- Long service life even with heavy-duty use
- High suction power thanks to large active suction surface and good sealing



## SL series made of Silicone – Food industry

FDA and EU1935/2004 compliant

- Flat and bellows vacuum cups
- For direct and indirect contact with foodstuffs
- Vacuum cups for handling baked goods or chocolates
- Vacuum cups for various primary packaging
- FDA-conformity
- Vacuum cups comply with American and European requirements for products with direct food contact
- Customised solutions are also possible



## SD series – Foils and paper

With and without cleats stabilisation

- Flat and bellows vacuum cups
- Support ribs prevent film and paper from being sucked in and creased
- Soft and flexible sealing lip for optimum sealing
- High cycle times possible



## Antistatic vacuum cups

Handling of electronic components

- Flat, bellows and oval vacuum cups
- Antistatic material (silicone AS or NBR AS)
- Prevents damage to electronic components due to uncontrolled electrostatic discharge
- For mounting electronic components





## Series SFU-R | SFU-RT | SOPL-R – Wood handling

Handling rough or structured surfaces

- Flat and oval vacuum cups
- Fine and flexible sealing lip
- Inner secondary sealing lip prevents dropping in the event of leakage due to product irregularities



## Bernoulli vacuum cups

Non-contact, deformation-resistant transport

- Also suitable for porous workpieces
- The gentlest handling
- When handling larger or heavier products, several Bernoulli vacuum cups can easily be combined



---

## Lifting cylinders

For stacking and destacking objects of all kinds

- Operated with vacuum or compressed air
- The top workpiece is lifted without the suction effect being exerted on the workpieces below
- Perfectly suited for short cycle times



## Spring levelers

Compensates for differences in height or the ejector stroke in injection moulding

- For fast cycle times in highly dynamic applications
- With no additional expense in control technology
- Non-rotating designs allow the use of oval vacuum cups



Spring levelers, secured against rotating by internal spring



Spring levelers with internal spring



Spring levelers Standard



Spring levelers Heavy-Duty



Spring levelers for direct vacuum cup mounting



## AREA GRIPPERS

### **Compact, lightweight and energy-saving - especially for use with cobots**

Three versions enable an infinite number of possible applications and always offer an optimum solution depending on the product and surface. The version with internal electric vacuum pump is a technical evolution in the field of energy efficiency and paves the way for compressed air-free production.

Cobots enable direct collaboration with team members and can be used flexibly and in a space-saving manner, especially for monotonous and physically demanding work steps. As a result, the goals of process improvement, cost savings and employee wellbeing can be achieved in parallel. An important consideration in the use of cobots is a suitable gripper which should be lightweight, universally usable and quick to integrate.

### **The Cobot Smart Gripper at a glance:**

- Smart handling: surface gripper for cobots and small industrial robots
- Cost-efficient: maximising efficiency and cost-effectiveness
- Solution-oriented: variable use and customer-oriented solution thanks to three product versions
- Compressed air-free production: version with internal electric vacuum pump
- Intelligent control with automatic energy saving
- Low dead weight: optimum utilisation of the robot payload
- Flexible use: pick and place in production and logistics
- Plug and play: gripper can be set up quickly and easily
- High compatibility: compatible with a wide range of cobots and industrial robots



## AREA GRIPPERS

### Solutions for automated handling

Grip and move individual products or product layers dynamically and reliably without changing grippers: Our FSG series area grippers can be used almost anywhere where the handling of larger parts is required. Typical applications can be found in the packaging industry.

And if the standard widths are not enough: the SBX-F is the premium area gripper for very high demands and complicated applications. It is characterised by maximum gripping reliability with maximum efficiency and minimum occupancy at the same time.

### Area grippers FSG at a glance:

- Low weight: the use of aluminum ensures high energy efficiency and saves operating costs
- Flexible vacuum supply: versions with integrated ejectors or with connection to central vacuum supply
- Process-safe function: flow reduction or check valves reduce leakage
- Versatile: customisation possible for any application

### Area grippers SBX-F at a glance:

- Secure gripping: vacuum level stays high even in case of low coverage
- High flexibility: free grid division of suction cells/ vacuum cups for optimum adaptation to the application
- Energy-efficient operation: fully closing valves minimise compressed air consumption
- Short cycle times: internal vacuum reservoir ensures fast vacuum build-up on the workpiece
- Optimal availability: all components required for operation can be quickly replaced



## VACUUM COMPONENTS

Our vacuum technology services range from individual components to the planning and delivery of complete systems. We cover the entire process chain – from vacuum generation and system peripherals to the active gripping elements at the interface to the goods to be handled.

You can find a wide range of vacuum components online at [www.fipa.com](http://www.fipa.com) or in the digital product catalogue.

- Ejectors
- Rotary vane vacuum pumps
- Vacuum filters
- Valve technology
- Vacuum and pressure switches
- Vacuum and pressure regulators
- Tubing
- Connecting elements



# HIGHEST PROFESSIONALISM

- It is crucial for the function of automation systems that all vacuum components work together optimally
- Screw fittings, plug-in connections and hoses connect the individual components
- Our vacuum components are designed for efficiency, space-saving and robustness and are consistently developed further in close cooperation with our customers and partners, on the basis of comprehensive test series and by constantly monitoring market requirements



## Generate

- The base of every vacuum system is vacuum generation
- Whether vacuum pump or ejector: a wide range of generators and technical solutions is available
- With different suction power and functionality, they cover different areas of application in the handling of goods



## Regulation

- Our control technology ensures a smooth, reliable vacuum cycle
- With our pressure and vacuum regulators, the operating pressure and vacuum level can be freely adjusted using rotary controls and can also be kept constant in automation applications with workpieces of varying porosity



## Control

- Our valve technology is optimised for vacuum and compressed air applications in automation and handling systems
- The range includes valves in many different designs, technologies and sizes



## Monitor

- We offer a range of high-performance components for controlling and monitoring system parameters in vacuum systems for automation and handling systems
- Components for system monitoring, such as vacuum and pressure switches, increase process reliability and enhance the dynamics of handling systems

## Ejectors

Working according to the Venturi-principle

- Inline ejectors: compact and light
- Heavy-duty ejectors: for harsh operating conditions
- Basic ejectors: for direct installation on the vacuum cup or solenoid valve
- Multi-chamber ejectors: require little compressed air and provide high suction capacity
- Compact ejectors: take up little space and provide a wide variety of functions



FGS Series  
Efficient and  
space-saving



FMC Series  
Hercules among the  
ejectors



FBM Series  
Small and quiet



MFE Series  
with automatic  
air-saving

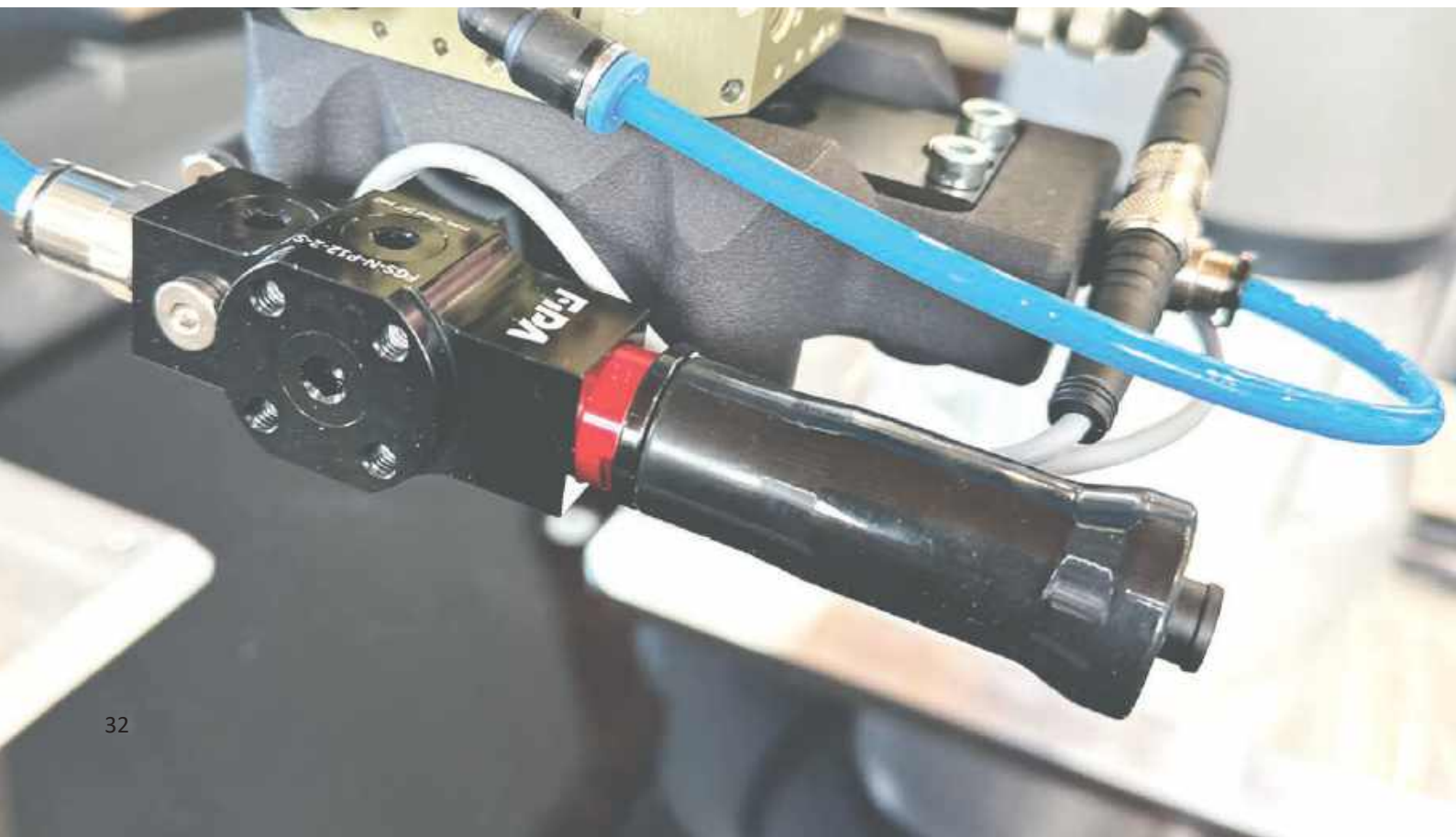



## Vacuum pumps

Compact vacuum generator

- Dry-running vacuum pumps are preferred in plants in the pharmaceutical, packaging and food industry
- Oil-lubricated vacuum pumps can be used both in dry and wet areas
- Uniform volume flow



---

## Side channel blowers

Vacuum generators for very high volume flows

- Safe handling of air-permeable workpieces, such as cardboard packaging or untreated softwood
- Two-stage design ensures a significantly higher vacuum level with the same high volume flow rate
- Side channel blowers are practically maintenance-free and suitable for continuous operation



## Vacuum filters

Protect systems from damage

- Vacuum filters protect vacuum generators against contamination, damage or moisture
- Pre-filter with paper insert for the dry area
- Universal filter for dry and wet areas
- Condensate separator for removing moisture contamination



## Valve technology

To control vacuum and compressed-air applications

- The 2/2-way and 3/2-way valves can control processes such as suctioning, venting and ventilation
- Directly controlled, internally vacuum-controlled, or compressed air-driven versions available
- Flow-control and touch valves for a wide array of handling applications



## Pneumatic vacuum switch

Control and monitoring of system parameters

- No electrical connection required
- Switching point can be freely adjusted via an adjusting screw
- Hysteresis permanently pre-set to 120 mbar (rel.)



## Electromagnetic vacuum switch

Control and monitoring of system parameters

- Max. switching capacity (DC to 28 V, AC to 250 V) 2 A
- Switching point can be freely adjusted via an adjusting screw
- Hysteresis fixed at 6 % from switching point



## Digital and analog vacuum and pressure switches

Control and monitoring of system parameters

- Digital PNP- or NPN-signal
- Analog voltage signal 1-5 V
- Switching point and hysteresis freely adjustable via 7-segment LED



## Vacuum and pressure regulators

Enable a constant vacuum level or pressure

- Pressure regulators for the defined reduction of the operating pressure when activating linear cylinders, guide carriages, etc.
- Vacuum regulators with external leakage are suitable for application with a generous control range
- Precision vacuum regulators for meticulous processes



### Pressure regulators

- Pressure adjustment by knurled screw
- Integrated overpressure protection
- Limiting of the holding force of grippers during End-of-Arm-Tooling



### Vacuum regulators with external leakage

- Adjustment by knurled screw
- Use as a safety valve
- Can also be used in dusty environments



### Precision vacuum regulators

- Highly precise, continuous vacuum adjustment via a rotary knob with locking mechanism
- Suitable for measuring or testing purposes



### Vacuum regulators

- Precise adjustment via induction regulator
- Installation of a vacuum gauge recommended
- Suitable for measuring or testing purposes

## Tubing and connecting elements

Use in various industries and applications

- Tubing in various diameters, colours and with different technical properties, versatile and robust
- Large assortment of threaded connectors
- Connecting elements for vacuum and compressed air circuits in automation and handling systems





## VACUUM TUBE LIFTER – FIPALIFTswift

### Move loads effortlessly

Intuitive, powerful, simple: Processes become faster and safer while at the same time relieving the strain on employees. The FIPALIFTswift is a particularly ergonomic tube lifter with a lifting capacity of up to 40 kg. It is designed for the rapid and frequent transfer of heavy loads. Whether parcels or crates, canisters or barrels. Even suitcases or bags in baggage handling at airports are no problem.

### FIPALIFTswift at a glance:

- Up to 40 kg load capacity \*
- Intuitive one-handed operation
- Ergonomic and efficient
- Working without effort
- Robust and durable
- For applications in all industries

\* Higher load capacity if required





## VACUUM TUBE LIFTER – FIPALIFTmax

### Universal use

The FIPALIFTmax with a lifting capacity of up to 160 kg is a flexible and durable solution to remove the risk for injury from lifting heavy objects. Suitable for handling everything from heavy sheets and plates to sacks, boxes and crates. All lifted with ease, enhancing wellbeing in the workplace. Its robust, yet attractive design allows it to be used in harsh production environments.

### FIPALIFTmax at a glance:

- Up to 160 kg load capacity \*
- Simple operation with rotary handle

\* Higher load capacity if required





## VACUUM LIFTER – FIPA Spider

Vacuum lifters are superior to classic lifting devices with slings due to their faster and easier handling. Place the vacuum cup, press the manual slide valve and wait two to three seconds until the vacuum is generated. Working with the FIPA Spider vacuum lifter is so easy!

The vacuum lifter FIPA Spider is a vacuum traverse that was developed with “plug and play” for use on a chain hoist. Vacuum traverses, also called vacuum lifters in general, are used for handling plates, panes and sheets. Vacuum lifters are especially used in the wood, sheet metal and glass processing industries. They make the loading of processing machines and the storage of various goods much easier.

### Vacuum lifters at a glance:

- For load capacities up to 250 kg and 500 kg as standard
- Quick and easy development of special versions thanks to modular design
- Holder for the crane ball for attaching the chain control to the operating handle
- Signal light for visual warning in noisy working environments
- Hinge for a flexible control panel ensures an upright position, even at low working heights
- Additional crossbars provide a larger suction surface and improve support for sagging materials
- Variable selection of vacuum cups, depending on the application





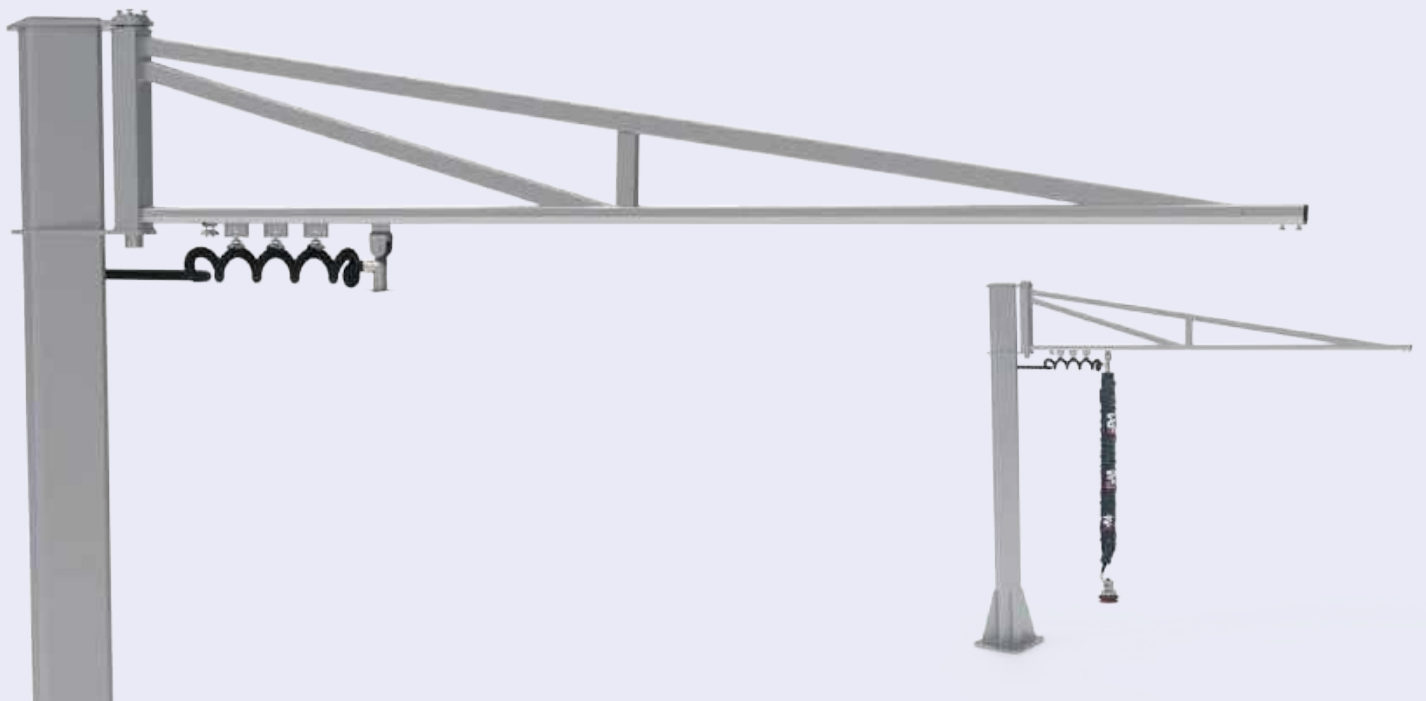

## CRANE TECHNOLOGY

From personalised advice, planning and design through to professional assembly, we also offer you complete crane systems. With the help of a competent and experienced design team, numerous customised solutions are possible in our crane projects to meet the individual requirements of your production environment.

Our crane systems are characterised by particularly smooth running, which is essential for ergonomic and energy-saving work. In this way, heavy loads can be transported from A to B gently and without high starting resistance using just one hand. Our crane technology is therefore the logical addition to the FIPALIFT tube lifters.

### Our crane technology range at a glance:

- Column mounted jib cranes
- Wall mounted jib cranes
- Overhead crane systems with aluminium rails
- Elevated crane systems
- Installation, service and crane inspections





Your global partner for

# VACUUM, GRIPPING AND LIFTING TECHNOLOGY

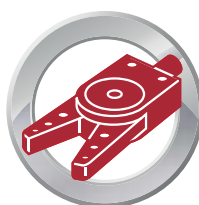

Our general terms and conditions apply, which you can find on the Internet at [www.fipa.com](http://www.fipa.com) or by phone at +49 89 962489-0 on request.

#### Copyright

All pages and their components are protected by copyright (all rights reserved). The designations, trademarks, logos, texts and images are the property of their respective owners and are to be as such.

Realisation: FIPA GmbH, Ismaning | 2024

#### Disclaimer

This brochure was created with the greatest possible care. Nevertheless FIPA cannot guarantee the correctness and accuracy of the information contained. FIPA excludes any liability for damages arising directly or indirectly from the use of the FIPA brochure, insofar as damage is not caused by intent or gross negligence on the part of FIPA.

FIPA shall not be liable for damage caused by finished assemblies already pre-assembled by FIPA if these have not been tested by the customer for their suitability for the respective application prior to commissioning.

FIPA GmbH  
Freisinger Strasse 30  
85737 Ismaning, Germany  
Phone +49 89 962489-0  
Fax +49 89 962489-11  
[info@fipa.com](mailto:info@fipa.com) | [www.fipa.com](http://www.fipa.com)

CEO: Rainer Mehrer  
Headquarters: Ismaning  
Commercial Register:  
Munich, HRB 104 684  
Sales Tax ID No: DE161864784



[www.fipa.com](http://www.fipa.com)