

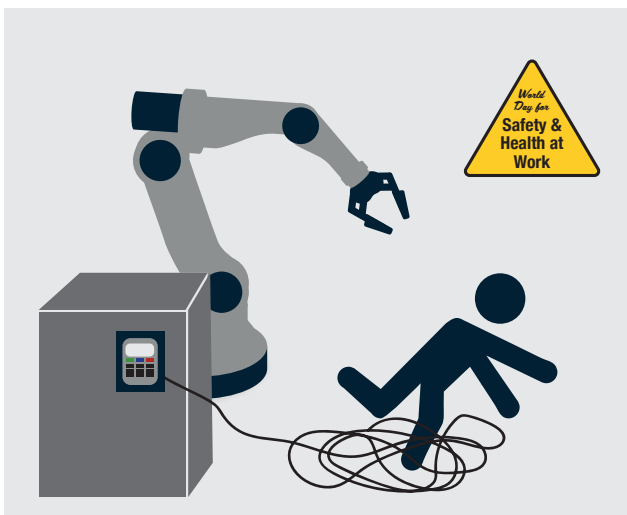

MTPReel-O™

The automatic cable reel for enhanced workplace safety



Safety First

The connecting cable can be extended to the desired length via a catch system and automatically retracted after use. The rewinding speed is reduced via an integrated brake module, which also ensures that the cable is rewound in a safe and orderly manner. So, hazardous situations, such as trip hazards or cable damage, are now a thing of the past.



Time saving

Time is an essential success factor within the industrial sector and the MTPReel™ helps to save time due to its intuitive operation. The rapid but careful rewinding of the connector cable saves time, which your employees can dedicate to other things.



Operating error avoidance

Using the MTPReel™ will ensure that the operating device is assigned unambiguously to the operator. Lengthy searches for the correct plug-in piece and potential operating errors due to incorrect combinations are avoided.



Plant safety optimisation

Properly storing the connector cable in the MTPReel™ protects it from dirt and accidental damage, which significantly increases its service life and improves safety within the operational facility.



Patented and tested system – made in Italy

Our partner company in Italy manufactures the MTPReel™ to the highest quality standards.

Technical specifications

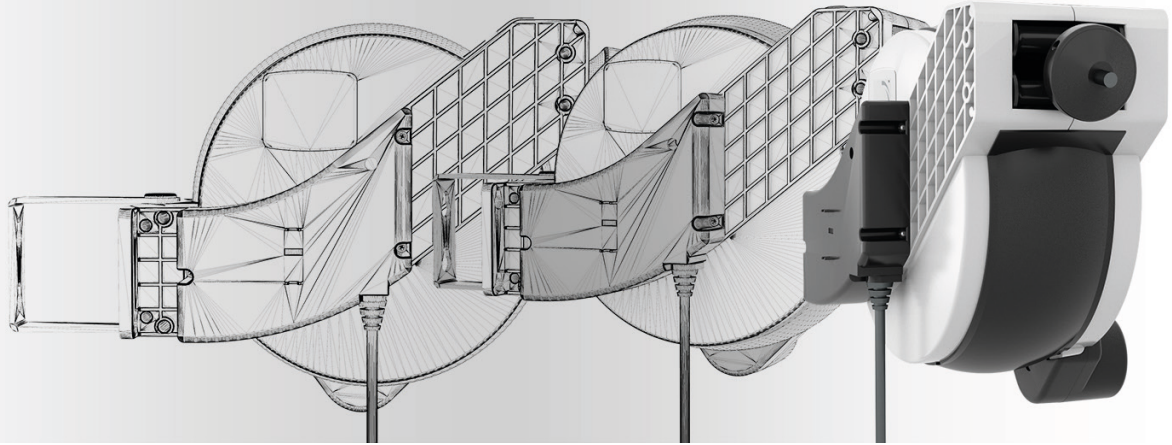

Robot-control	Model	Length of the extendible cable to the handheld operator panell	Length of power cable to the switch cabinet
Stäubli ENGEL KEBA KUKA KUKA INDUSTRIES	MTPReel-O™*	Up to max. 20 m	2,5 m bis 7,0 m

Additional Box Sizes, cable lengths and controller systems available upon request.

MTPReel-O™ - Installation Guide



1 Feed the original SmartPAD cable through the guide rollers



2 Plug the male cable end into the built-in female connector



3 Adjust the strain relief cleat to suit



4 Fasten the cable tie around the outer sheath of the cable



5 Trim off the excess cable tie



6 Insert the plug cover



7 Lock the cover in place by applying pressure



8 The cable as finally installed



9 Attach the cable retraction stopper to the connector cable about 1 - 1.5 m from the SmartPAD



10



11 Undo the locking bolt on the pretensioned drum coil



12 Be careful when removing the locking bolt!



13 Manually wind the connector cable onto coil the first time



14 Place the cover on the attached cover guides at the rear



15 Insert the central guide pins by tilting the cover to the side and then pressing it into place