



**领航换枪盘**

---

**AUTOMATIC TOOL CHANGERS**

# LT Factory



Linghang Robot specializes in production and sales of tool changing devices, flexible end clamps, automatic connection technology, and related products for worldwide market. We provide excellent production solutions for all manufacturers, to make them achieve high capacity, lower costs, more stable quality and automatic. Assist manufacturers to develop their business better.

As the top manufacturer in China for Robot tool changer, we always give top priority to product quality, through technology and product innovation, we committed to providing customers with better solutions. Now our products have been widely used in palletizing, transportation, vacuum, polishing, welding, laser, stamping, gluing, Ethernet, data acquisition and other industries. Due to the modular design, it can be adjusted unlimited for robot application and adapt to different production processes and new technologies. Based on tens of thousands of application cases, LT has more than 1000 different types of products, which can easily solve all kinds of robot applications. Headquartered in Zhengzhou, China, the company has a production plant of 25,000 square meters, and a team of 120 people.

# LT Factory

## Automatic production workshop



CNC



Mazak machining center



CNC lathe



Fully stocked

- ◆ R&D team 20 persons, Production workshop 25 persons, warehouse 5 persons ,QC 10 persons,Sale man more than 30 persons.
- ◆ The annual output about 100,000 sets, full sotcked of common models.
- ◆ Full range of models, OEM accepted.



# LT Company



Zhengzhou R&D, operation center



LT Team



Leadership care



Leadership care



Leadership care



Leadership care

# TIMELINE

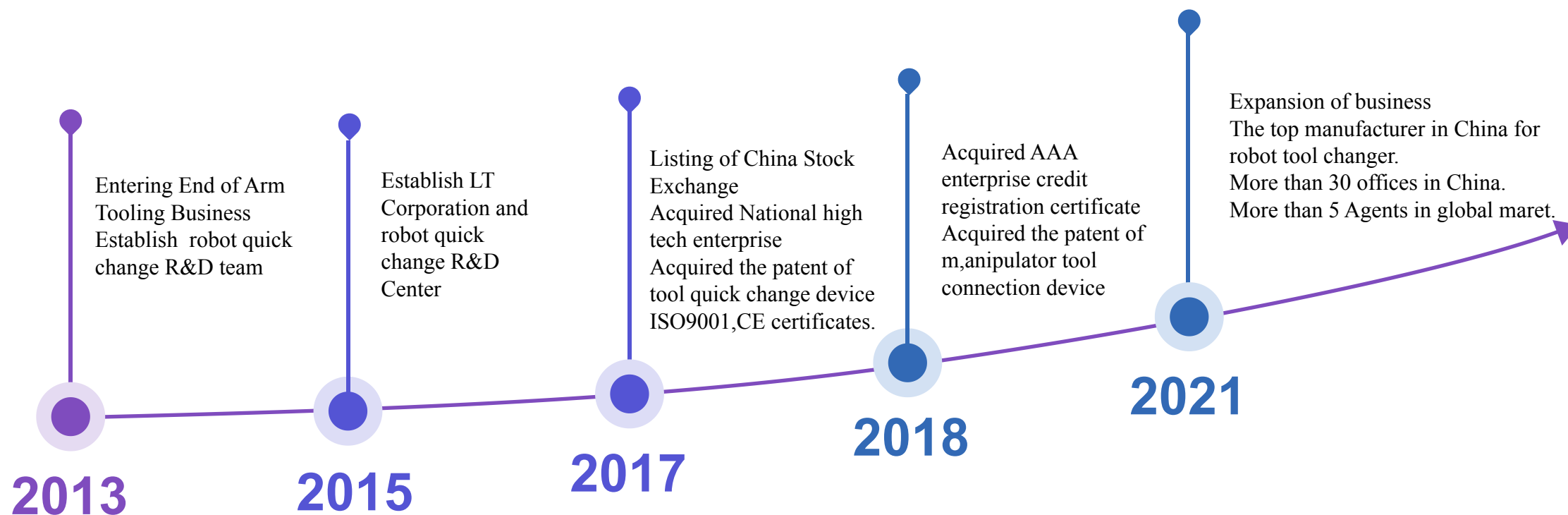



# Exhibition



The 22nd CIIF 2020



GERMAN HANNOVER MESSE



The 13th Vietnam INT'L Exhibition



AMTS auto equipment exhibition in 2019

## Exhibition Activities

# GLOBAL SERVICE NETWORK

390 DISTRIBUTORS

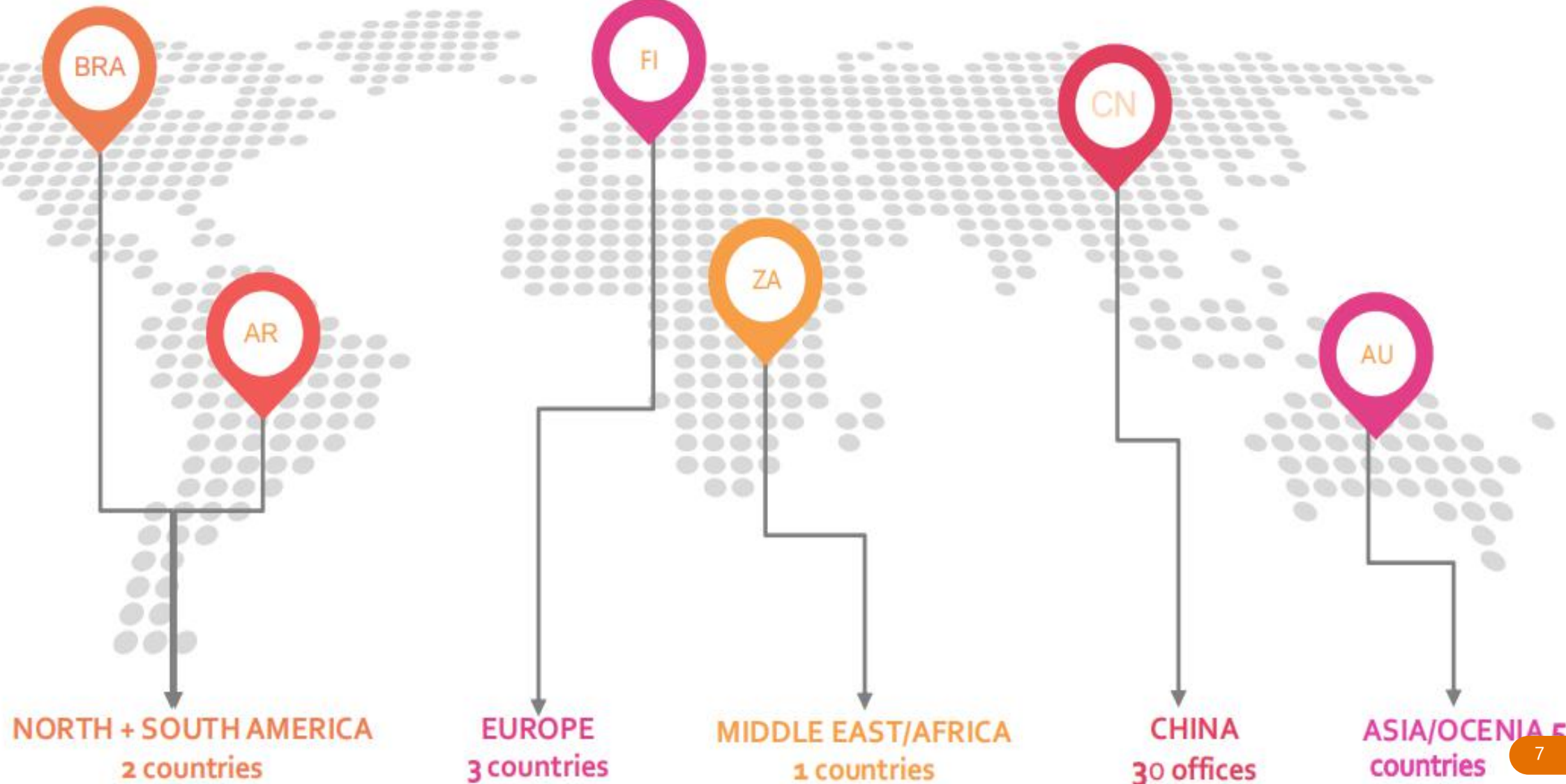

# COOPERATIVE PARTNER





# Certificates

Qualification and honor

High-tech enterprise

National honor

20 patents ,5 software copyrights



EU CE certificate



... ISO45001



ISO9001



ISO14001

# Main products



## Robot Tool Changers

The payload from 5kg to 2300kg for choose, support more applications with plenty of optional modules



## Floating energy coupler

Provide energy connection between master station and slave station, With X, y, Z, R direction floating performance, eliminate docking error, Docking includes power, data, i/o, air, liquid and other media

# Robot Tool Changer

Application : stamping workshop, engine manufacturing, auto parts

Payload 5kg~2300kg , more than 30 plate models、 more than 200 Electrical modules





## 2.3 Moduels



### IO Signal module

outgoing module ;  
aviation connector module ;  
Redundancy design makes signal  
transmission more stable



### Servo motor module

1000W、 2000W、 3000Wservo  
motor for choose



### Bus communication module

Support Ethernet、  
EtherNetIP、 EtherCAT、  
PROFINET、 DEVICENET、  
PROFIBUS、 CC-LINK ,etc



### AC 390V Module

5A、 20A、 150A Power module



### Gas and liquid module

all kind open gas module ;  
self sealing gas module ;  
Cooling water module



### High-frequency module

Single,Double  
outgoing, aviation connector  
etc for choose

( more than 200 models for choose )

# Characteristics :

- Quality
- Safety
- Easy to debug

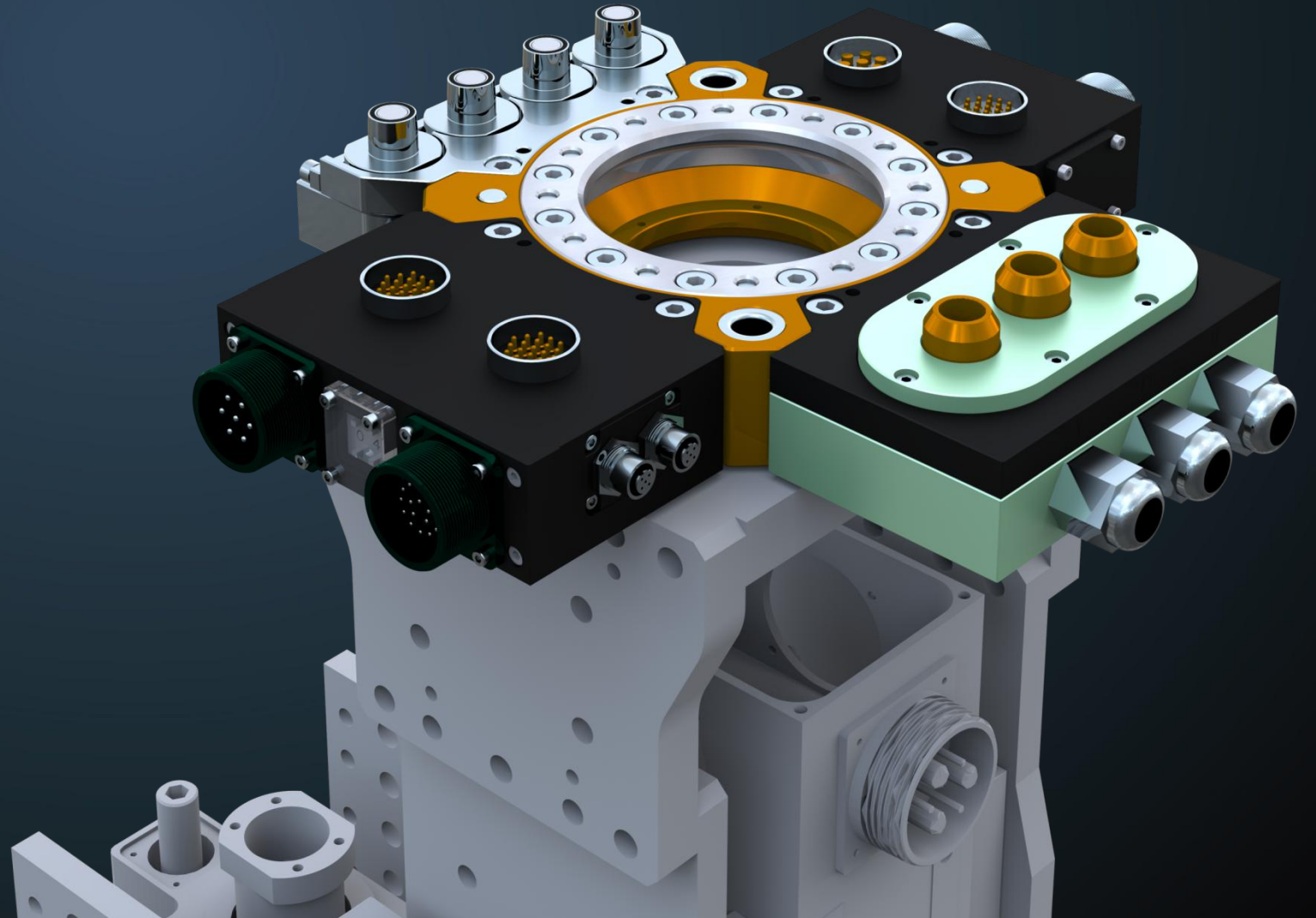

## 2.4 Strict quality control



Full test of seals :  
**5** indicators

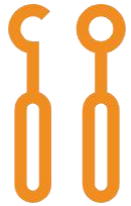

The probe test :  
**5** indicators



Force of locking mechanism :  
**5** indicators



Full function test before delivery :  
**12** indicators



module solder joint :  
**12** indicators



Test of mechanical parts :  
**16** indicators



production Process HACCP : **22**



Product production process traceability:  
information archiving



## 2.5 Product features1 : technological quality

### 3 million times

--Locking force and repeat precision guarantee

- Rockwell hardness : HRC58
- More stable metal structure
- Excellent anti rust performance
- High chromium steel ball and magnesium aluminum alloy shell, 12.9 Grade a high strength bolt



## 2.6 Product features2 : Safety

### 1、 Mechanical self-locking structure

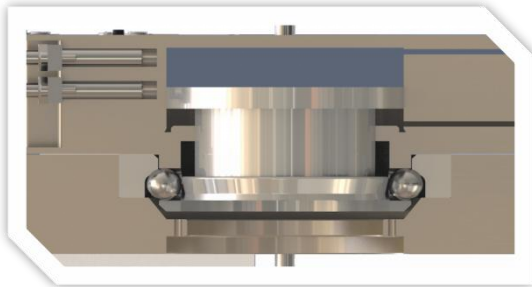

locked positions



Unlocked positions

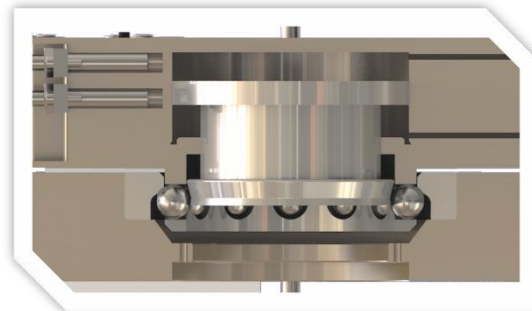

Loss of pressure quto lock

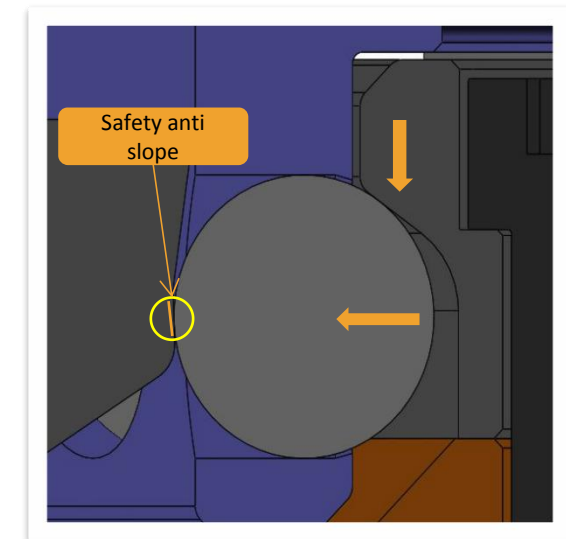
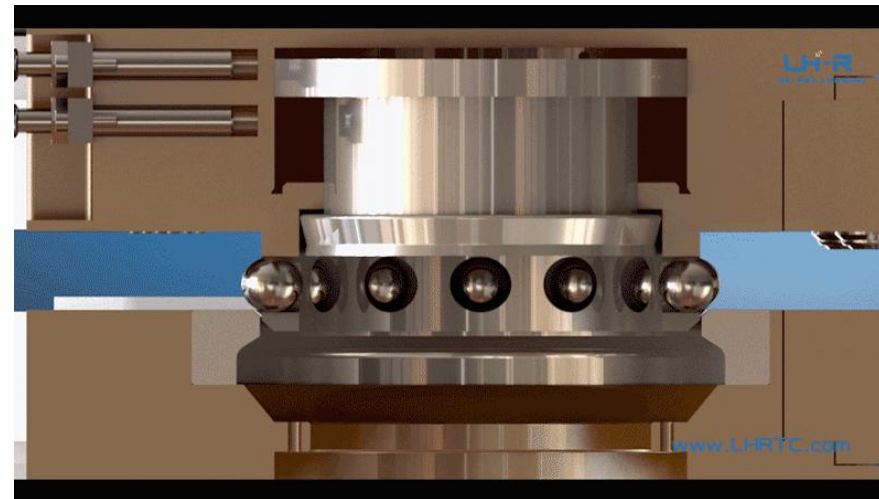

## 2.7 Product features2 : Safety

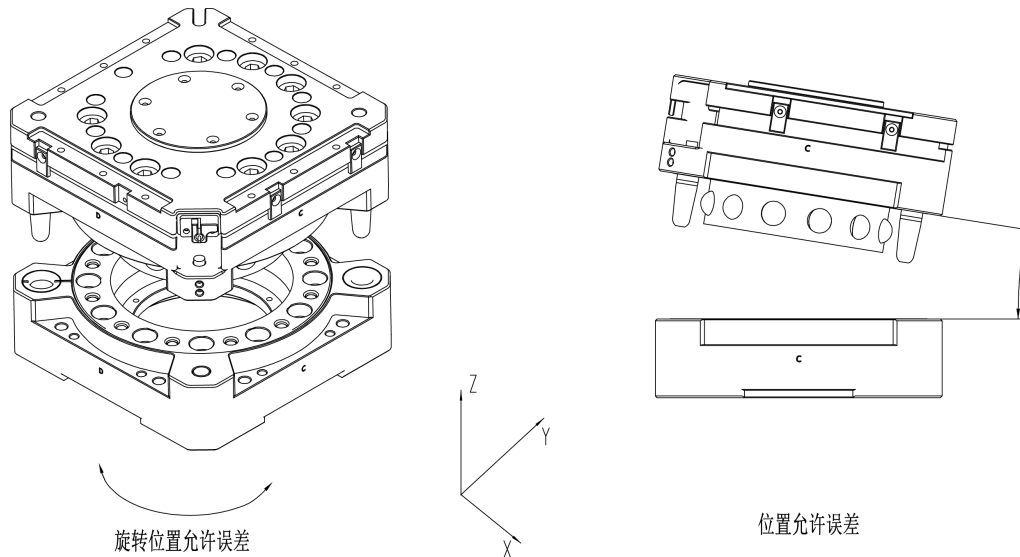

Allowable horizontal position deviation	2mm
Allowable rotational position deviation	1deg
Allowable position deviation	0.7deg

- Non contact locking technology allows locking operation when the spacing is 2.5mm ;
- Connecting flange based on ISO9409-2 standard,directly installed on Fanuc , ABB , Motoman etc, popular robot models , No transition flange is required
- Two ready to lock sensors send ready to lock signal when the distance between master side and tool side is 1.5mm ;  
The tool changes of sensor detection tool is in the position of locking, opening and no tool locking ;  
Sensor choose is PNP or NPN



# 2.8

## Product features2 : Safety

# 2、 Safe Parking system

- The patented tool bracket interlock function, when the tool changer works normally, even if the industrial robot mistakenly outputs the opening instruction to the solenoid valve module, the tool changers will not implement the opening operation.



Program interlock

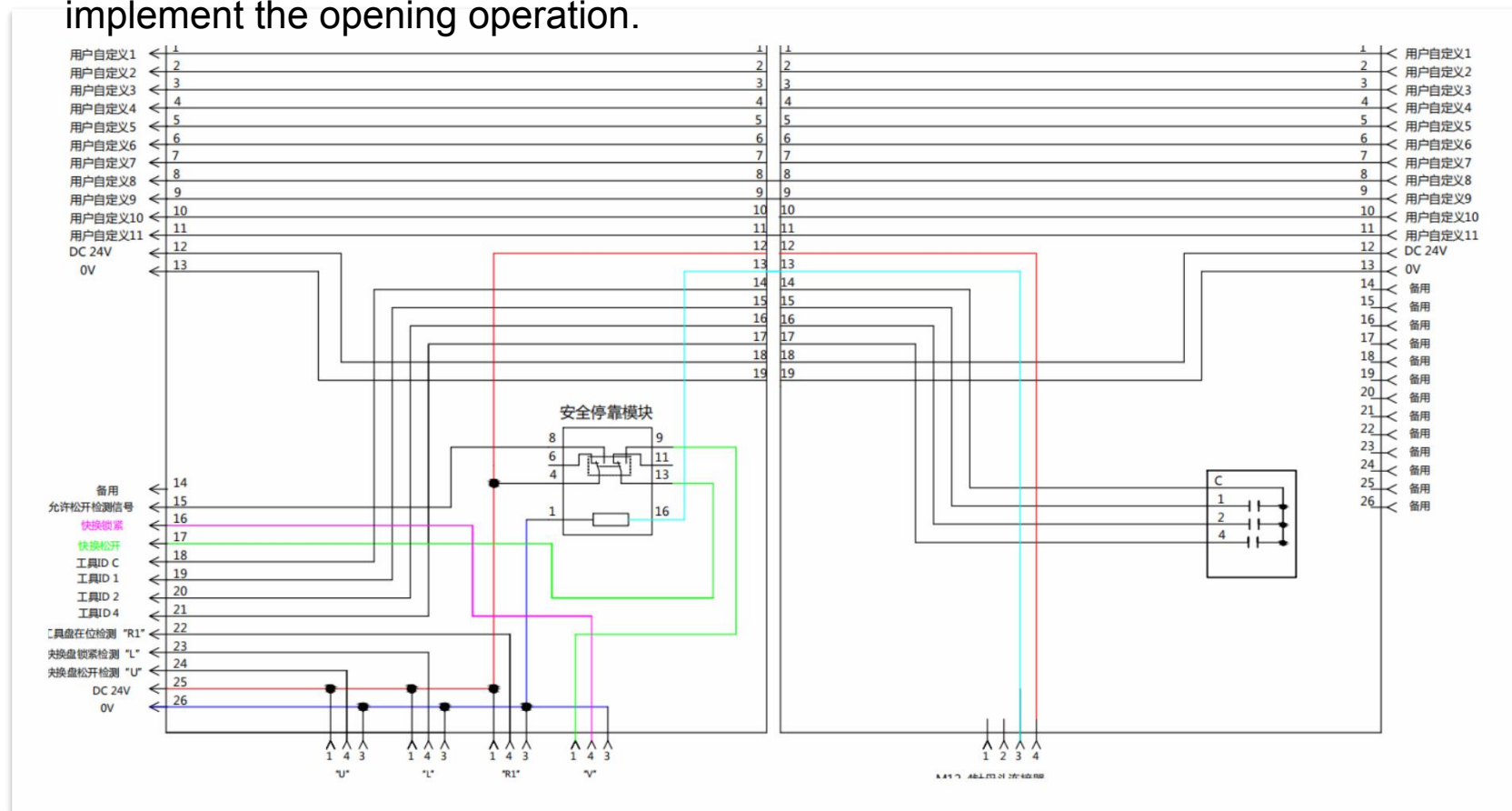

## 2.9 Product features3 : Easy to debug



### Locating pin

Anti jamming locating pin structure  
Locking and separation are more smooth and easy to debug



### Tool identification

It is more convenient to automatically identify the address of the tool tray and execute the corresponding process



### LED status visible

LED status display, convenient for debugging personnel  
External connection of M12, convenient for maintenance or replacement of after-sales personnel

## 2.10 Product features4 :

### Redundant signal --- improve the connection stability

Redundancy design is an important method for system or equipment to obtain high reliability. By adding more functional channels in the product, the system can operate normally when a channel fails.

LT electrical signal module adopts the design method of active static redundancy to ensure the high quality and reliability of signal transmission.

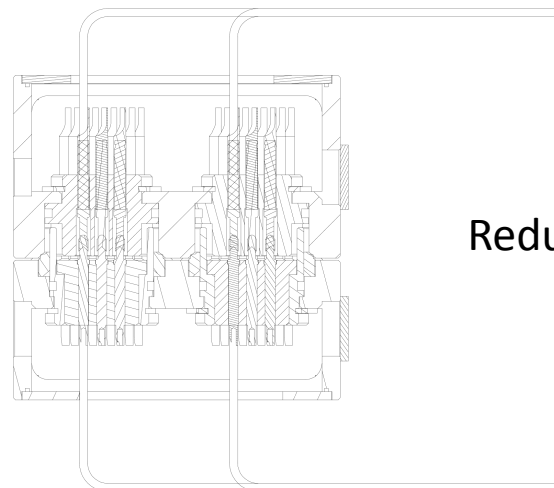

Redundancy dynamic diagram



3.Zero voltage high needle, contact first and then separate, protect electrical components

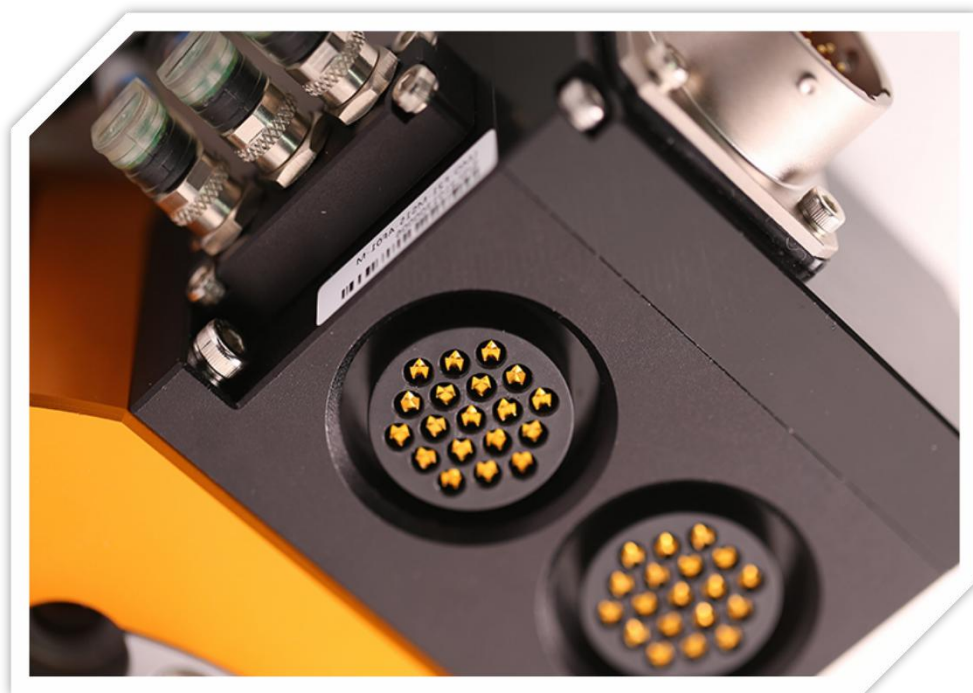

# 3

## Water vapor module

Service life of more than one million times

Self cleaning scale function, not afraid of water quality impact

Stainless steel material, more durable

Constant micro hanging liquid quantity

More convenient maintenance mode and lower maintenance cost





# Automobile industry Applications



BYD engine production line

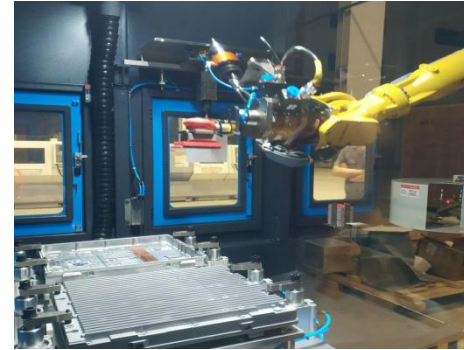

Tesla motor shell processing



SANY heavy industry



Boyi bumper production line



Welding of exhaust pipe of Jinfeng automobile



Zhengguang automobile headlamp production line



Wuhan Changhua Auto Parts



Dongfeng Nissan Zhengzhou factory



Welding workshop of SAIC passenger car



# General industry Applications



Handling



Warehouse assembly

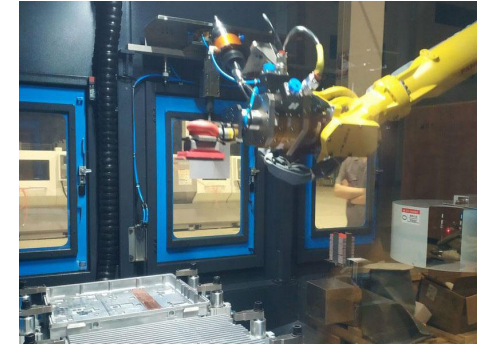

Grinding and deburring

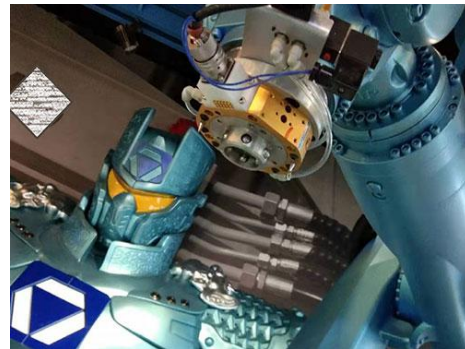

Welding handling



Mineral loading and unloading

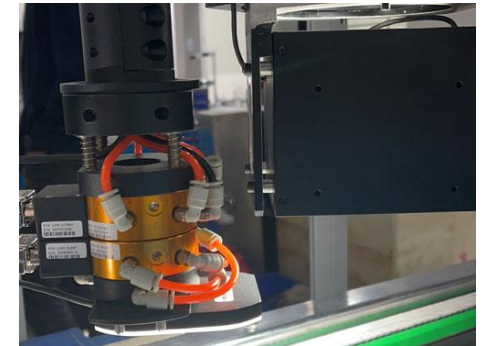

Bolt inspection workstation

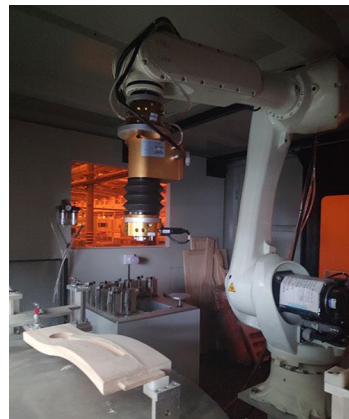

Grinding and deburring of wood furniture

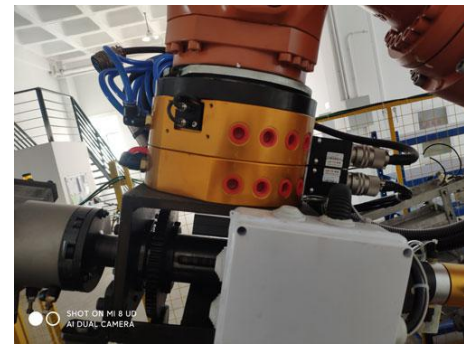

Loading and unloading



High flexibility production line

# Thank you!