



Extrusion systems | Clamps for shafts

Long angle clamps – with ball joint

Long angle clamps – with ball joint

ANGLE CAN BE FREELY ADJUSTED

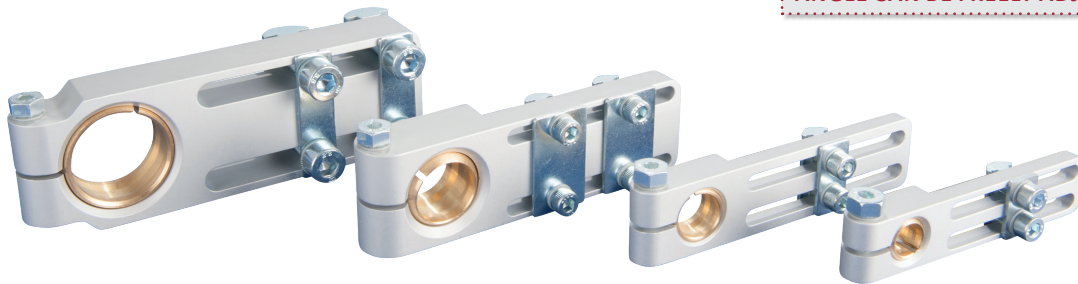

Product notes

- > Ball joint enables variable angular adjustment of gripper components
- > Allows for adjustment parallel and perpendicular to the profile frame

Technical data

Item no.	Suitable for extrusion system	Clamping \varnothing [mm]	Angular adjustment [°]	Weight [g]
GR02.035	SLine / MLine	10	38	48
GR02.036	SLine / MLine	14	33	60
GR02.037	SLine / MLine	20	31	145
GR02.038	SLine / MLine	30	28	238
GR02.420	MLine / JLine	10	38	43
GR02.421	MLine / JLine	14	33	67
GR02.422	MLine / JLine	20	31	153
GR-XL02.038	XLine	30	28	260

Dimensions

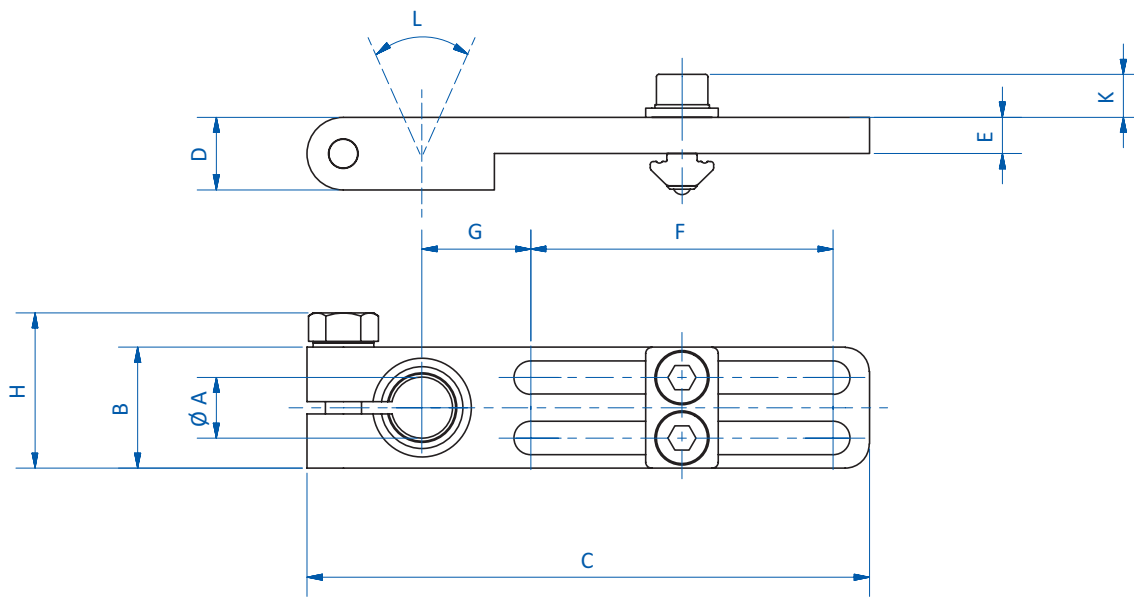

GR02.035 | GR02.036 | GR02.037 | GR02.038 | GR-XL02.038



Dimensions

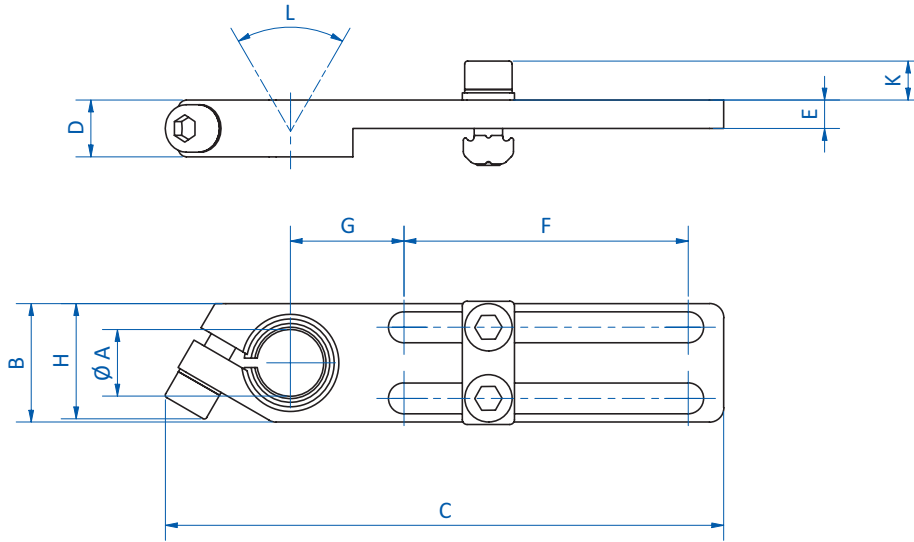

GR02.420 | GR02.421 | GR02.422

Item no.	Ø A [mm]	B [mm]	C [mm]	D [mm]	E [mm]	F [mm]	G [mm]	H [mm]	K [mm]	L [°]
GR02.035	10	20	93	12	6	50	18	25.7	7.1	38
GR02.036	14	25	107	12	6	60	20	30.7	7.1	33
GR02.037	20	35	115	20	10	60	24	40.7	7.1	31
GR02.038	30	45	136	20	17	70	30	45.7	7.1	28
GR02.420	10	20	98	12	6	50	20	20	7.1	38
GR02.421	14	25	118	12	6	60	24	24	8.2	33
GR02.422	20	35	134	20	10	60	29	34	8.2	31
GR-XL02.038	30	45	136	20	20	70	30	45.7	10.3	28