

Control technology at a glance	635
Pressure regulators	636
Vacuum regulators	640

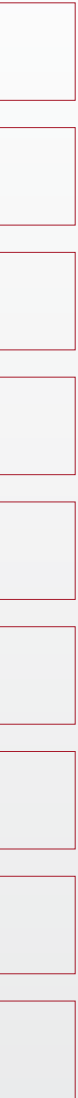

Notes:



Lined area for writing notes, featuring a vertical red line on the left and horizontal lines for text entry.



FIPA control technology

- > Setting defined pressure or vacuum level value in vacuum or gripper systems

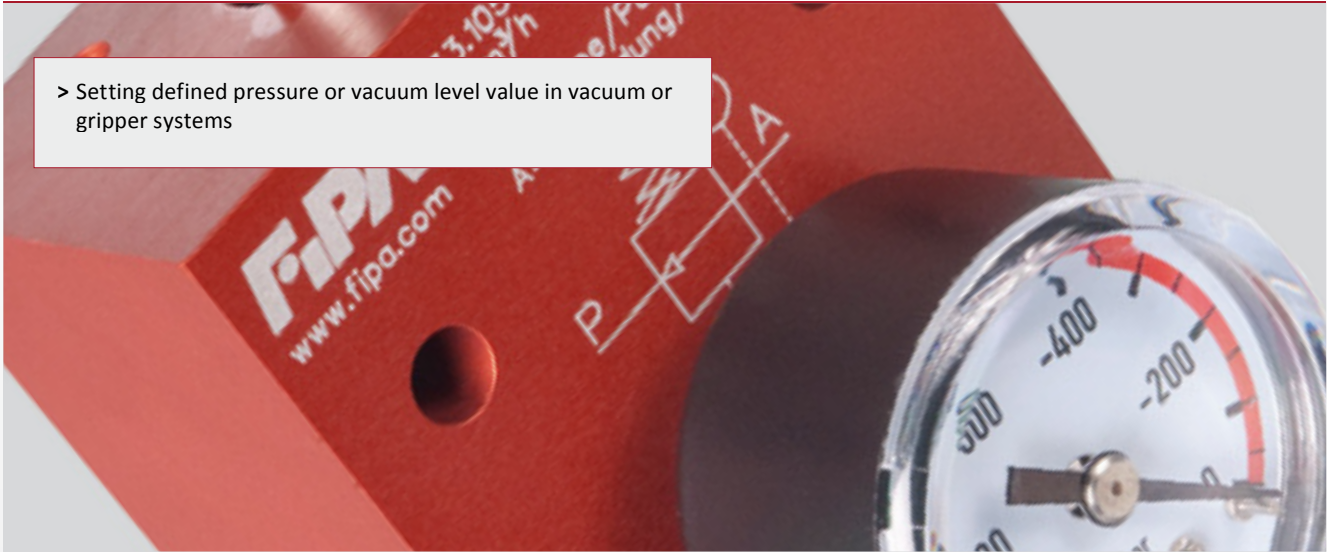
**Pressure regulators**

- > Defined reduction in operating pressure for compressed air-operated vacuum generators (ejectors)
- > Limitation of gripper holding force in End-of-Arm-Tooling
- > Simple adjustment
- > Models for inline installation available

> See page 636

**Vacuum regulators with external leakage**

- > Limitation of vacuum level, e.g. from rotary-vane pumps or vacuum tanks (safety adjustment)
- > Can also be used in dust-contaminated environments
- > Simple adjustment

> See page 640

**Vacuum regulators**

- > Maintenance of system vacuum independently of air-permeability of workpiece and of fluctuations in the vacuum supply
- > Precise adjustment
- > Suitable for measuring or testing purposes

> See page 642



Pressure regulators - screw-in type



Product Description

- > Defined reduction in operating pressure for ejectors, limitation of holding force of grippers
- > Pressure adjustment by means of knurled screw
- > Integrated overpressure protection

Notes

- > Only suitable for compressed air

Technical data

Item no.	Operating pressure [bar]	Regulating range [bar]	Accuracy (\pm) [%]	Operating temperature [$^{\circ}$ C]	Weight [g]
32.570	0 - 9	1 - 8	5	0 - 60	16
32.571	0 - 9	1 - 8	5	0 - 60	36
32.572	0 - 9	1 - 8	5	0 - 60	17
32.573	0 - 9	1 - 8	5	0 - 60	37
32.574	0 - 9	1 - 8	5	0 - 60	59
32.575	0 - 9	1 - 8	5	0 - 60	38
32.576	0 - 9	1 - 8	5	0 - 60	60

Dimensions

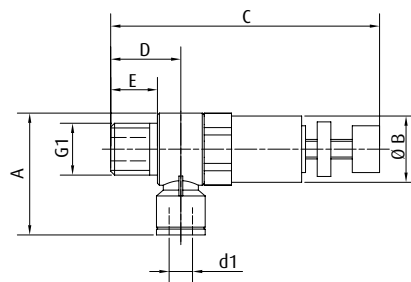

Item no.	G1	d1 [mm]	A [mm]	Ø B [mm]	C [mm]	D [mm]	E [mm]
32.570	M5	4	20.5	10	48.5	9	3.5
32.571	R1/8	4	28.5	14	60	14.5	8
32.572	M5	6	22.5	10	48.5	9.5	3.5
32.573	R1/8	6	30.5	14	60	14.5	8
32.574	R1/4	6	34	17	65	17.5	11
32.575	R1/8	8	34	14	60	15.5	8
32.576	R1/4	8	37	17	65	18.5	11



Pressure regulators - screw-in type, with pressure gauge



Product Description

- > Defined reduction in operating pressure for ejectors, limitation of holding force of grippers
- > Pressure adjustment by means of knurled screw, pressure monitoring by means of gauge (readout in MPa)
- > Integrated overpressure protection

Notes

- > Only suitable for compressed air

Technical data

Item no.	Operating pressure [bar]	Regulating range [bar]	Accuracy (\pm) [%]	Operating temperature [$^{\circ}$ C]	Weight [g]
32.587	0 - 9	1 - 8	5	0 - 60	28
32.588	0 - 9	1 - 8	5	0 - 60	55
32.589	0 - 9	1 - 8	5	0 - 60	28
32.590	0 - 9	1 - 8	5	0 - 60	55
32.591	0 - 9	1 - 8	5	0 - 60	84
32.592	0 - 9	1 - 8	5	0 - 60	55
32.593	0 - 9	1 - 8	5	0 - 60	84

Dimensions

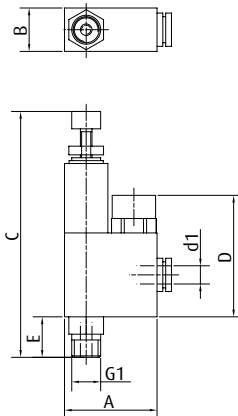

Item no.	G1	d1 [mm]	A [mm]	B [mm]	C [mm]	D [mm]	E [mm]
32.587	M5	4	27.5	15	57.5	42	3.5
32.588	R1/8	4	36	15	81.5	42	8
32.589	M5	6	28	15	57.5	42	3.5
32.590	R1/8	6	36.5	15	81.5	42	8
32.591	R1/4	6	39.5	19	89.5	42	11
32.592	R1/8	8	36.5	15	81.5	42	8
32.593	R1/4	8	39.5	19	89.5	42	11



"Inline" pressure regulators



Product Description

- > Defined reduction in operating pressure for ejectors, limitation of holding force of grippers
- > Pressure adjustment by means of knurled screw
- > Integrated overpressure protection

Notes

- > Only suitable for compressed air

Technical data

Item no.	Operating pressure [bar]	Regulating range [bar]	Accuracy (\pm) [%]	Operating temperature [$^{\circ}$ C]	Weight [g]
32.577	0 - 9	1 - 8	5	0 - 60	36
32.578	0 - 9	1 - 8	5	0 - 60	36
32.579	0 - 9	1 - 8	5	0 - 60	36
32.580	0 - 9	1 - 8	5	0 - 60	60
32.581	0 - 9	1 - 8	5	0 - 60	60

Dimensions

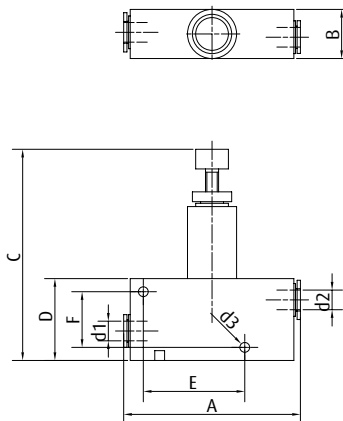

Item no.	d1 [mm]	d2 [mm]	d3 [mm]	A [mm]	B [mm]	C [mm]	D [mm]	E [mm]	F [mm]
32.577	4	4	3.2	44	15	63	25	30	17
32.578	6	4	3.2	44.5	15	63	25	30	17
32.579	6	6	3.2	45	15	63	25	30	17
32.580	8	6	3.2	57	19	68	29	39	21
32.581	8	8	3.2	57	19	68	29	39	21



"Inline" pressure regulators with pressure gauge



Product Description

- > Defined reduction in operating pressure for ejectors, limitation of holding force of grippers
- > Easy installation thanks to vertical and horizontal cross-holes
- > Pressure adjustment by means of knurled screw, pressure monitoring by means of gauge (readout in MPa)
- > Integrated overpressure protection

Notes

- > Only suitable for compressed air

Technical data

Item no.	Operating pressure [bar]	Regulating range [bar]	Accuracy (\pm) [%]	Operating temperature [$^{\circ}$ C]	Weight [g]
32.582	0 - 9	1 - 8	5	0 - 60	48
32.583	0 - 9	1 - 8	5	0 - 60	48
32.584	0 - 9	1 - 8	5	0 - 60	48
32.585	0 - 9	1 - 8	5	0 - 60	73
32.586	0 - 9	1 - 8	5	0 - 60	73

Dimensions

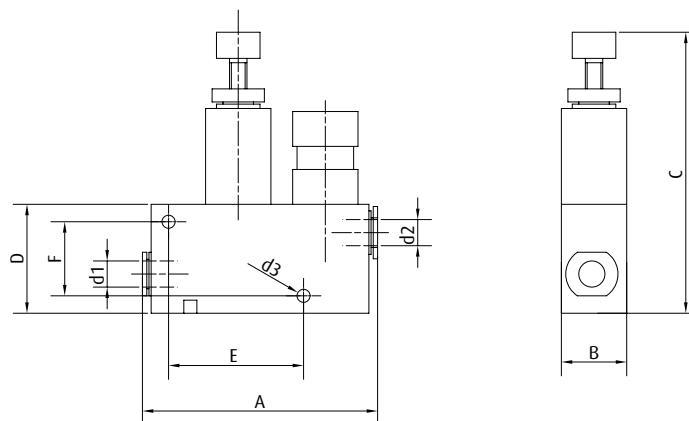

Item no.	d1 [mm]	d2 [mm]	d3 [mm]	A [mm]	B [mm]	C [mm]	D [mm]	E [mm]	F [mm]
32.582	4	4	3.2	55	15	63	25	30	17
32.583	6	4	3.2	55.5	15	63	25	30	17
32.584	6	6	3.2	56	15	63	25	30	17
32.585	8	6	3.2	69	19	67.5	29	39	21
32.586	8	8	3.2	69	19	67.5	29	39	21



Vacuum regulators with external leakage

Safety control valve particularly for oil-free rotary-vane pumps



Product Description

- > Setting a constant vacuum level when handling workpieces with varying porosities or leakage
- > Suitable as safety valve if dry-running rotary-vane pumps are to run continuously at maximum vacuum
- > Control of vacuum through automatic venting when a preset vacuum level is reached
- > Manual adjustment via fine thread, mechanical opening via spring load

Notes

- > Turn the knob towards the (+) to increase the vacuum threshold value at which the regulator will start drawing in outside air. Turn the knob towards the (-) to reduce this value.

Ordering notes

- > On request suitable as safety valve for side channel blowers to limit the max. vacuum level (diameter of regulator and blower inlet should be identical)

Technical data

Item no.	Maximum control volume [m ³ /h]	Regulating range [mbar]	Operating temperature [°C]	Weight [g]
73.002	16	-999 - 0	-20 - 80	270
73.003	40	-999 - 0	-20 - 80	658

Dimensions

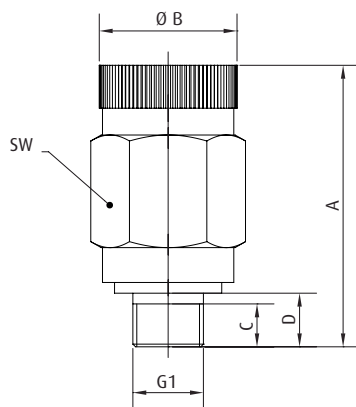

73.002

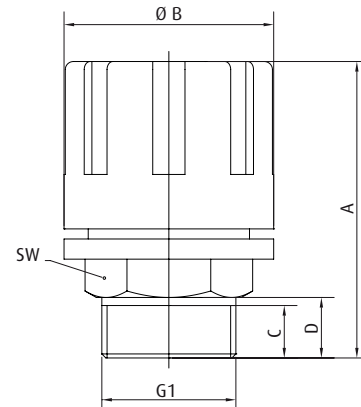

73.003

Item no.	G1	A [mm]	Ø B [mm]	C [mm]	D [mm]	SW
73.002	G1/4	63	26	8	10	25
73.003	G1	82	52	13	15	32



Vacuum regulators



Product Description

- > Vacuum adjustment of consumer loads, such as vacuum cups in handling systems
- > Automatic compensation of fluctuations in vacuum supply
- > Highly precise, continuous vacuum adjustment via a rotary knob with locking mechanism
- > Suitable for conducting leakage tests for inspection / measurement purposes

Notes

- > Turning the rotary knob clockwise increases the vacuum on the consumer side (SET) with the vacuum generator connected (VAC)

Ordering notes

- > Included in scope of delivery: Vacuum gauge incl. connection adapter

Technical data

Item no.	Maximum flow rate [m ³ /h]	Regulating range [mbar]	Accuracy [mbar]	Operating temperature [°C]	Weight [g]	Suitable vacuum gauge
33.220	8.4	-999 - 0	< 1.3	5 - 60	135	91.001-R (p.696)
33.220-G1/4	8.4	-999 - 0	< 1.3	5 - 60	135	91.001-R (p.696)
33.230	14	-999 - 0	< 1.3	5 - 60	250	91.001-R (p.696)
33.230-G1/2	14	-999 - 0	< 1.3	5 - 60	250	91.001-R (p.696)
33.230-G1/4	14	-999 - 0	< 1.3	5 - 60	250	91.001-R (p.696)

Dimensions

G1	d1 [mm]
--	8
G1/4	--
--	8
G1/2	--
G1/4	--

Dimensions

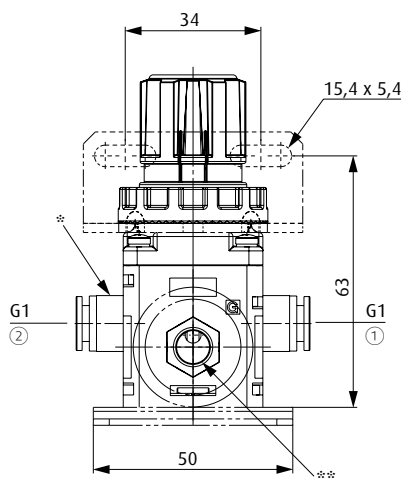

33.220 | 33.220-G1/4

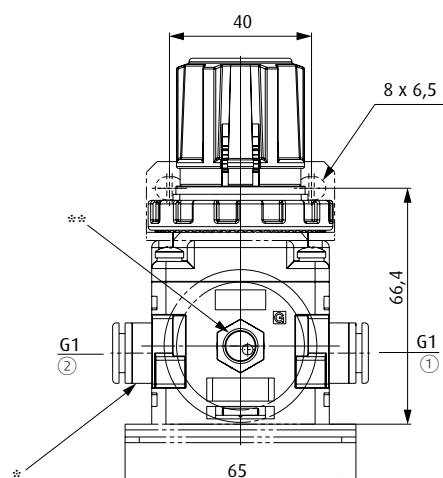

33.230 | 33.230-G1/2 | 33.230-G1/4

① = Connection to the vacuum cup / product side (description SET) ② = Pump connection (description VAC) * = Plug connection
 ** = R1/8 Gauge connection



Vacuum regulators



Vacuum regulator 33.105 with vacuum gauge

Product Description

- > Vacuum adjustment of consumer loads, such as vacuum cups in handling systems
- > Integration of a vacuum gauge recommended
- > Blow-off is possible if vacuum gauge is not connected
- > Any installation position

Technical data

Item no.	Maximum flow rate [m ³ /h]	Regulating range [mbar]	Operating temperature [°C]	Weight [kg]	Suitable vacuum gauge
33.105	10	-200 - -999	-10 - 80	0.6	91.001 (p.696)
33.120	80	-200 - -999	-10 - 80	2.1	91.003 (p.696)

Dimensions

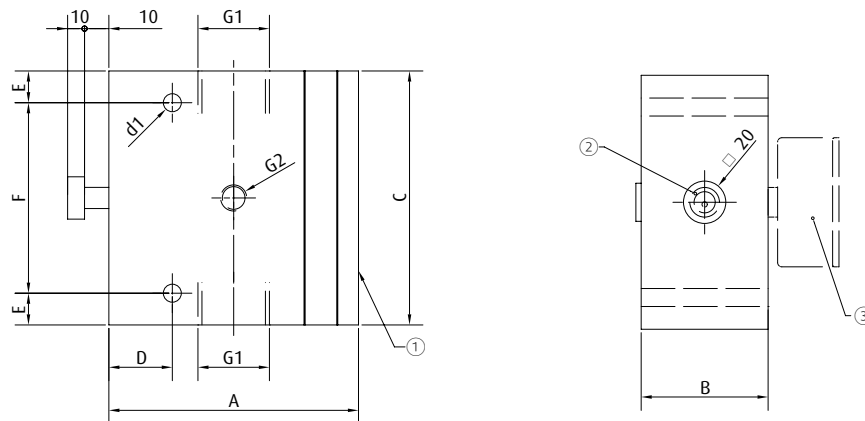

① = The bottom side must not be covered ② = Adjusting screw ③ = Vacuum gauge (optional)

Item no.	G1	G2	A [mm]	B [mm]	C [mm]	D [mm]	d1 [mm]	E [mm]	F [mm]
33.105	G3/8	G1/8	89	40	60	20	6.5	10	40
33.120	G1	G1/4	118	60	120	30	8.5	15	90