

Inline ejectors	513
Base and Heavy-duty ejectors	526
Multi-chamber ejectors	546
Compact ejectors	555
Feed ejectors	569
Silencers for vacuum ejectors	577
Rotary vane vacuum pumps	580
Vacuum units	606
Side channel blowers	614
Accessories	617

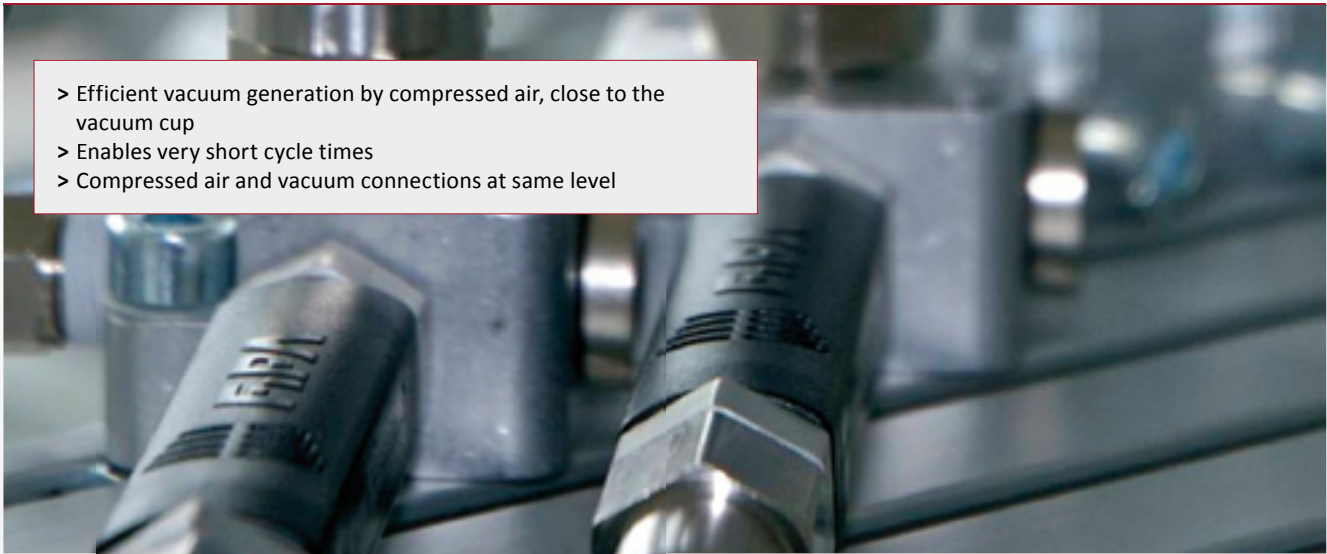

FIPA Inline ejectors



- > Efficient vacuum generation by compressed air, close to the vacuum cup
- > Enables very short cycle times
- > Compressed air and vacuum connections at same level



Inline ejectors EIL

- > Handling of dense workpieces (max. vacuum level 85 % / 90 %): Index H
- > Handling of porous workpieces (higher suction power, max. vacuum level 60 % / 68 %): Index L
- > Compressed air-saving operation at only 3.5 bar (max. vacuum level 90 %) for the handling of dense workpieces: Index P

> See page 514



Inline ejectors EIL expandable

- > Very high mechanical strength
- > Application e.g. directly with vacuum suction plates in the wood industry
- > Direct vacuum monitoring through simple connection of vacuum switches
- > Short cycle times thanks to easy connection with a blow-off unit

> See page 520

Examples of use

- > Handling of lightweight parts
- > Pick & place applications
- > Separation systems in sheet metal or plastic manufacturing
- > Handling of electrical components

Functional principle

Ejectors work according to the Venturi principle and generate vacuum $\square V$ from compressed air $\square P$. Vacuum is created in the subsequent chamber as a result of the high flow speed after the primary nozzle. "Used" compressed air and suctioned air leave the ejector through the secondary nozzle. Either a silencer or an exhaust air duct can be connected to the outlet $\square Ex$.

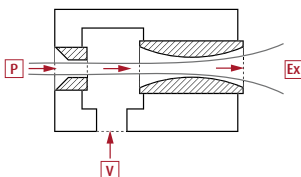



Inline ejectors EIL

Compressed air and vacuum connection via quick fittings, lateral exhaust



Series 1
 Series 2
 V = Vacuum connection P = Compressed air connection Ex = Exhaust outlet

Product Description

- > Easy installation close to the vacuum cup
- > High suction power enables short gripping times

Ordering notes

- > Index H: Ejectors for non air permeable products (max. vacuum degree 85 % / 90 %)
- > Index L: Ejectors for air permeable products, resp. in case of higher leakage (increased suction, max. vacuum degree 60 % / 68 %)
- > Index P: Ejectors designed for lower feed pressure (max. vacuum degree 90 %)

Technical data

Item no.	Series	Nozzle diameter [mm]	Optimal feed pressure [bar]	Suction power at 5 bar [N/min]	Air consumption at 5 bar [N/min]	Final vacuum at 5 bar [%]	Evacuation time 0 to 70 % [s/l]	Evacuation time 0 to 45 % [s/l]	Weight [g]	Suitable accessories
EIL.05H.1	1	0.5	5	8	14	85	13	--	13	Plug-in filter 71.071 (p.628)
EIL.05H.2	1	0.5	5	8	14	85	13	--	15	--
EIL.05H.4	2	0.5	5	7	11.5	90	10	--	18.5	Plug-in filter 71.070 (p.628) Fitting EIL.05-HO (p.524)
EIL.05L.1	1	0.5	5	14	14	60	--	4	13	Plug-in filter 71.071 (p.628)
EIL.05L.2	1	0.5	5	14	14	60	--	4	15	--
EIL.05L.4	2	0.5	5	12	11.5	68	--	3.2	18.5	Plug-in filter 71.070 (p.628) Fitting EIL.05-HO (p.524)
EIL.07H.1	1	0.7	5	13	28	85	7.5	--	13	Plug-in filter 71.071 (p.628)
EIL.07H.2	1	0.7	5	13	28	85	7.5	--	15	--
EIL.07H.4	2	0.7	5	13	23	90	6	--	20	Plug-in filter 71.070 (p.628) Fitting EIL.07-HO (p.524)
EIL.07L.1	1	0.7	5	28	28	60	--	2	13	Plug-in filter 71.071 (p.628)
EIL.07L.2	1	0.7	5	28	28	60	--	2	15	--
EIL.07L.4	2	0.7	5	20	23	68	--	1.6	20	Plug-in filter 71.070 (p.628) Fitting EIL.07-HO (p.524)
EIL.07P.4	2	0.7	3.5	10	17	90	12	--	20.5	Plug-in filter 71.070 (p.628) Fitting EIL.07-HO (p.524)
EIL.07P.1	2	0.7	3.5	10	17	90	12	--	19	Plug-in filter 71.071 (p.628) Fitting EIL.07-HO (p.524)



Dimensions

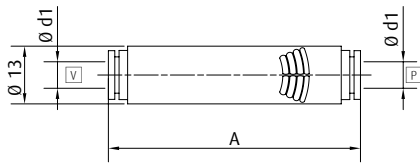

EIL.05H.1 | EIL.05L.1 | EIL.07H.1 | EIL.07L.1

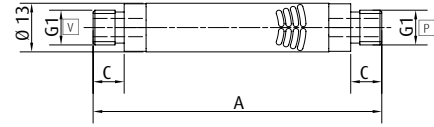

EIL.05H.2 | EIL.05L.2 | EIL.07H.2 | EIL.07L.2

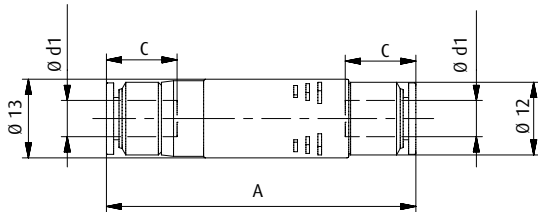

EIL.05H.4 | EIL.05L.4 | EIL.07H.4 | EIL.07L.4 | EIL.07P.4 | EIL.07P.1

V = Vacuum connection P = Compressed air connection

Item no.	G1	d1 [mm]	A [mm]	C [mm]
EIL.05H.1	--	6	61	--
EIL.05H.2	G1/8	--	78	8
EIL.05H.4	--	4	49	11
EIL.05L.1	--	6	61	--
EIL.05L.2	G1/8	--	78	8
EIL.05L.4	--	4	49	11
EIL.07H.1	--	6	61	--
EIL.07H.2	G1/8	--	78	8
EIL.07H.4	--	4	55.5	11
EIL.07L.1	--	6	61	--
EIL.07L.2	G1/8	--	78	8
EIL.07L.4	--	4	55.5	11
EIL.07P.4	--	4	55.5	11
EIL.07P.1	--	6	57	11.5

Diagrams

> Series 1: Suction power and air consumption against feed pressure

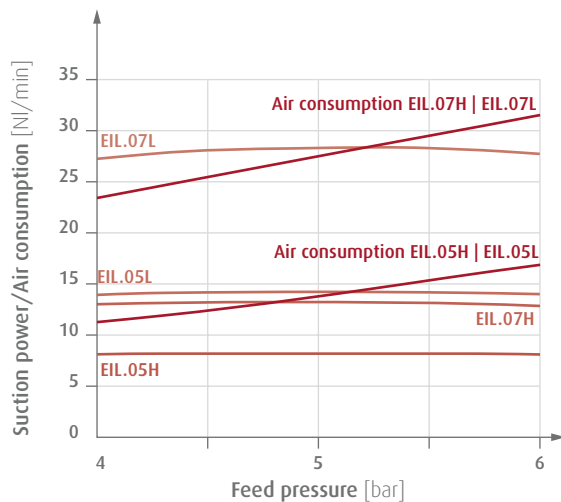

> Series 1: Vacuum level against feed pressure

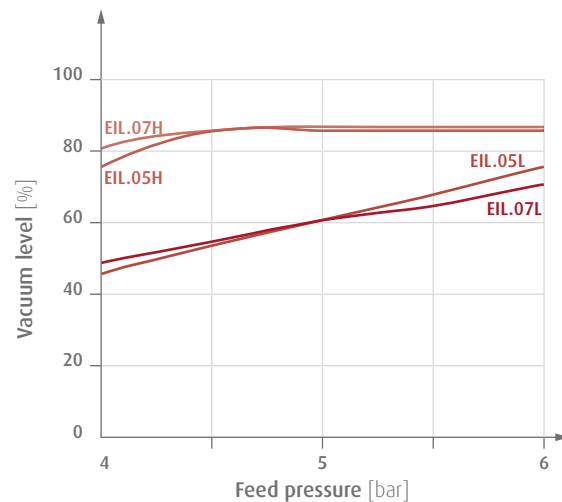

Continued on the next page



Diagrams

> Series 2: Suction power and air consumption against feed pressure

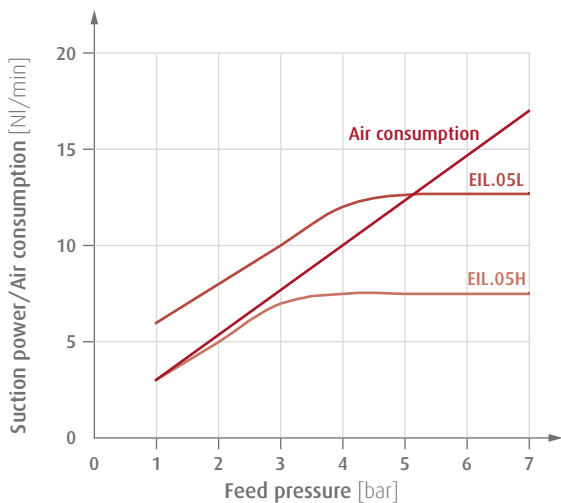

> Series 2: Vacuum level against feed pressure

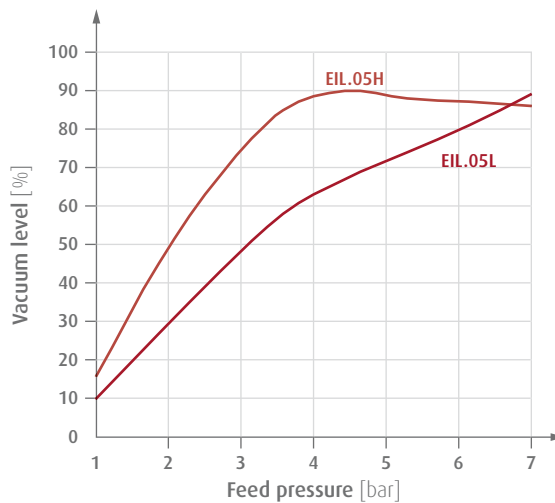

> Series 2: Suction power and air consumption against feed pressure

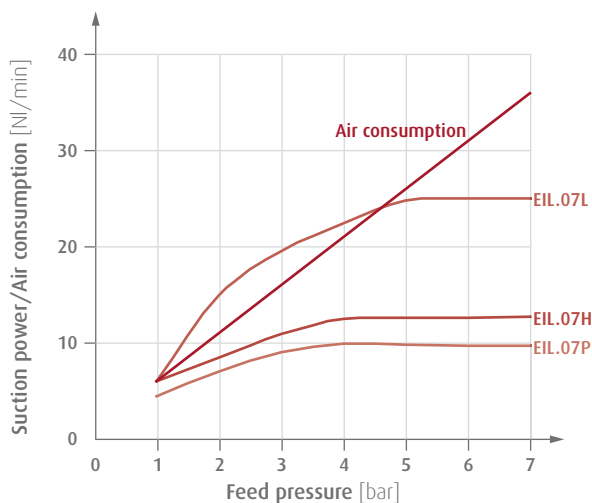

> Series 2: Vacuum level against feed pressure

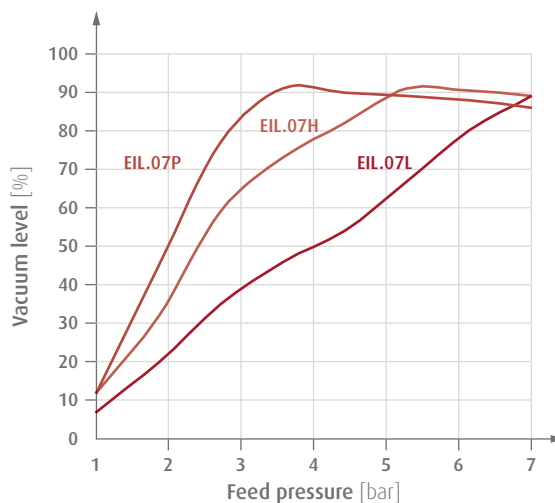

Suction power [NI/min] at vacuum level

Item no.	0 %	10 %	20 %	30 %	40 %	50 %	60 %	70 %	80 %
EIL.05H.1	8	5.3	4.2	3.9	3.3	2.5	1.3	0.4	0.1
EIL.05H.2	8	5.3	4.8	3.9	3.3	2.5	1.3	0.4	0.1
EIL.05H.4	7	6.2	5.4	4.6	3.8	3.1	2.3	1.5	0.7
EIL.05L.1	14	11.9	9	6.8	4.3	2.2	0.1	--	--
EIL.05L.2	14	11.9	9	6.8	4.3	2.2	0.1	--	--
EIL.05L.4	12	10.2	8.3	6.5	4.7	2.9	1.1	--	--
EIL.07H.1	13	10.8	9.2	8.1	7	5.2	4.1	2.7	1.1
EIL.07H.2	13	10.8	9.2	8.1	7	5.2	4.1	2.7	1.1
EIL.07H.4	13	11.5	10.1	8.7	7.2	5.8	4.4	3	1.5
EIL.07L.1	28	26	22.1	17.6	10.8	5.4	1.9	--	--
EIL.07L.2	28	26	22.1	17.6	10.8	5.4	1.9	--	--
EIL.07L.4	22	18.7	15.3	12	8.6	5.3	2	--	--
EIL.07P.4	10	8.9	7.7	6.6	5.5	4.4	3.3	2.2	1.1
EIL.07P.1	10	8.9	7.7	6.6	5.5	4.4	3.3	2.2	1.1



Inline ejectors EIL

Compressed air, vacuum and exhaust via quick fittings, two fixing holes



V = Vacuum connection **P** = Compressed air connection **Ex** = Exhaust outlet

Product Description

- > Easy installation close to the vacuum cup
- > High suction power for short gripping time

Ordering notes

- > Index H: Ejectors for dense products (max. vacuum degree 90 %)
- > Index L: Ejectors for air permeable products, resp. in case of higher leakage (increased suction, max. vacuum degree 68 %)
- > Index P: Ejectors designed for lower feed pressure (max. vacuum degree 90 %)

Technical data

Item no.	Nozzle diameter [mm]	Optimal feed pressure [bar]	Final vacuum at 5 bar [%]	Suction power at 5 bar [Nl/min]	Air consumption at 5 bar [Nl/min]	Evacuation time 0 to 70 % [s/l]	Evacuation time 0 to 45 % [s/l]	Weight [g]	Suitable accessories
EIL.05H.1-B	0.5	5	90	7	11.5	13	--	19.5	Fitting EIL.05-HO (p.524) Filter element FEE8.2x2 Plug-in filter 71.071 (p.628)
EIL.05H.4-B	0.5	5	90	7	11.5	13	--	21	Fitting EIL.05-HO (p.524) Filter element FEE8.2x2 Plug-in filter 71.070 (p.628)
EIL.07H.1-B	0.7	5	90	13	23	7	--	20.5	Fitting EIL.07-HO (p.524) Filter element FEE8.2x2 Plug-in filter 71.071 (p.628)
EIL.07H.4-B	0.7	5	90	13	23	7	--	22.5	Fitting EIL.07-HO (p.524) Filter element FEE8.2x2 Plug-in filter 71.070 (p.628)
EIL.05L.1-B	0.5	5	68	12	11.5	--	4	19.5	Fitting EIL.05-HO (p.524) Filter element FEE8.2x2 Plug-in filter 71.071 (p.628)
EIL.05L.4-B	0.5	5	68	12	11.5	--	4	21	Fitting EIL.05-HO (p.524) Filter element FEE8.2x2 Plug-in filter 71.070 (p.628)
EIL.07L.1-B	0.7	5	68	22	23	--	1.6	20.5	Fitting EIL.07-HO (p.524) Filter element FEE8.2x2 Plug-in filter 71.071 (p.628)
EIL.07L.4-B	0.7	5	68	20	23	--	1.6	22	Fitting EIL.07-HO (p.524) Filter element FEE8.2x2 Plug-in filter 71.070 (p.628)
EIL.07P.1-B	0.7	3.5	90	10	17	7.5	--	20.5	Fitting EIL.07-HO (p.524) Filter element FEE8.2x2 Plug-in filter 71.071 (p.628)
EIL.07P.4-B	0.7	3.5	90	10	17	7.5	--	22	Fitting EIL.07-HO (p.524) Filter element FEE8.2x2 Plug-in filter 71.070 (p.628)

Continued on the next page →



Dimensions

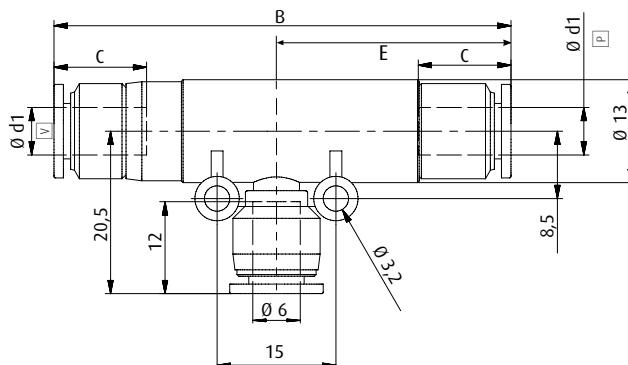

∇ = Vacuum connection P = Compressed air connection

Item no.	Ø d1 [mm]	B [mm]	C [mm]	E [mm]
EIL.05H.1-B	6	50.5	11.5	22.5
EIL.05H.4-B	4	49	11	22
EIL.07H.1-B	6	57	11.5	26
EIL.07H.4-B	4	55.5	11	25.5
EIL.05L.1-B	6	50.5	11.5	22.5
EIL.05L.4-B	4	49	11	22
EIL.07L.1-B	6	57	11.5	26
EIL.07L.4-B	4	55.5	11	25.5
EIL.07P.1-B	6	57	11.5	26
EIL.07P.4-B	4	55.5	11	25.5

Diagrams

> Suction power and air consumption against feed pressure

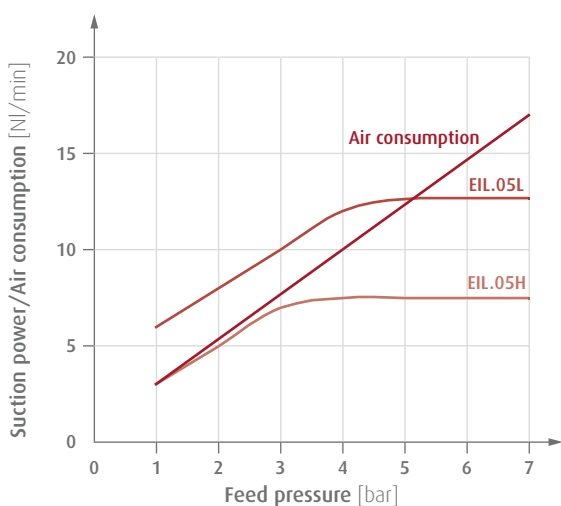

> Vacuum level against feed pressure

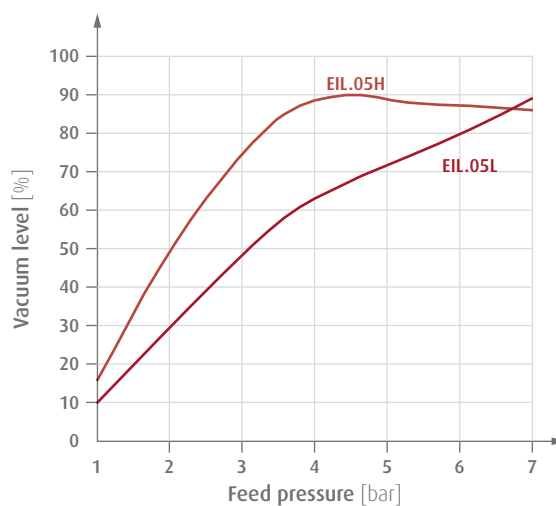



Diagrams

> Suction power and air consumption against feed pressure

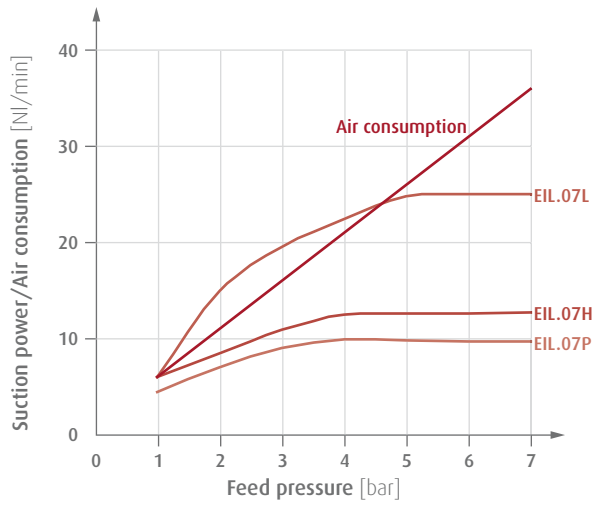

> Vacuum level against feed pressure

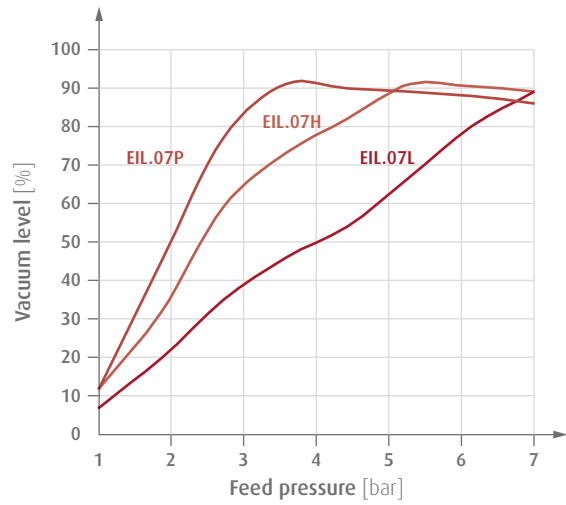

Suction power [Nl/min] at vacuum level

Item no.	0 %	10 %	20 %	30 %	40 %	50 %	60 %	70 %	80 %	90 %
EIL.05H.1-B	7	6.2	5.4	4.6	3.8	3.1	2.3	1.5	0.7	--
EIL.05H.4-B	7	6.2	5.4	4.6	3.8	3.1	2.3	1.5	0.7	--
EIL.07H.1-B	13	11.5	10.1	8.7	7.2	5.8	4.4	3	1.5	0.1
EIL.07H.4-B	13	11.5	10.1	8.7	7.2	5.8	4.4	3	1.5	0.1
EIL.05L.1-B	12	10.2	8.3	6.5	4.7	2.9	1.1	--	--	--
EIL.05L.4-B	12	10.2	8.3	6.5	4.7	2.9	1.1	--	--	--
EIL.07L.1-B	22	18.7	15.3	12	8.6	5.3	2	--	--	--
EIL.07L.4-B	22	18.7	15.3	12	8.6	5.3	2	--	--	--
EIL.07P.1-B	10	8.9	7.7	6.6	5.5	4.4	3.3	2.2	1.1	--
EIL.07P.4-B	10	8.9	7.7	6.6	5.5	4.4	3.3	2.2	1.1	--



Inline ejectors EIL, expandable

Compressed air, vacuum connection and exhaust via G-threads

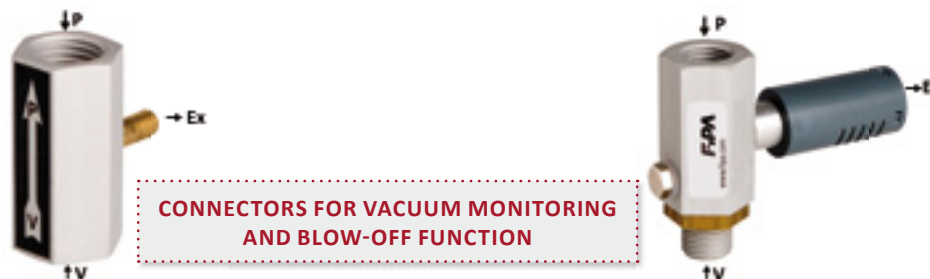

Series EIL.05 - EIL.09

Series EIL.10 - EIL.14 optionally with silencer

TV = Vacuum connection P = Compressed air connection Ex = Exhaust outlet

Product Description

- > High suction power for short gripping time
- > Easy installation directly on the vacuum cup
- > Compact design for installation where space is limited
- > Robust aluminium body
- > Very short cycle time using optional blow-off function
- > Vacuum switch connection for high process reliability
- > Effective noise reduction through open and closed silencers

Ordering notes

Connection blow-off device

- > Connection via M5-female
- > EIL.05-09: with I18 vacuum connection
- > EIL.10-14: always be connected

Connection of check valve with blow-off device 32.638

- > Connection to the vacuum outlet

Silencers

- > EIL.05-09: Closed diffuser silencer (72.045)
- > EIL.10-14: See item number specification

Vacuum monitoring: Connection to the ejector via M5-female

- > EIL.05-09: Vacuum switch connection possible with I18 vacuum connection
- > EIL.10-14: Vacuum switch can always be connected via M5-female

Technical data

Item no.	Nozzle diameter [mm]	Optimal feed pressure [bar]	Final vacuum [%]	Suction power at 5 bar [N/min]	Air consumption at 5 bar [N/min]	Operating temperature [°C]	Weight [g]	Suitable accessories
EIL.05	0.5	5	87	7	12	-10 - 80	20	Vacuum switch 20.040 (p.689), Vacuum switch 20.041 (p.689), Silencer 72.045 (p.578)
EIL.07	0.7	5	90	14	21	-10 - 80	20	Vacuum switch 20.040 (p.689), Vacuum switch 20.041 (p.689), Silencer 72.045 (p.578)
EIL.09	0.9	5	90	21	36	-10 - 80	20	Vacuum switch 20.040 (p.689), Vacuum switch 20.041 (p.689), Silencer 72.045 (p.578)
EIL.10	1	5	90	27	44	-10 - 80	50	Check valve 32.638 (p.674), Blow-off device 32.660 (p.525), Vacuum switch 20.040 (p.689), Vacuum switch 20.041 (p.689), Silencer 72.000 (p.578), Silencer 72.028 (p.577)
EIL.12	1.2	5	90	45	66	-10 - 80	50	Check valve 32.638 (p.674), Blow-off device 32.660 (p.525), Vacuum switch 20.040 (p.689), Vacuum switch 20.041 (p.689), Silencer 72.000 (p.578), Silencer 72.028 (p.577)
EIL.14	1.4	5	90	64	108	-10 - 80	50	Check valve 32.638 (p.674), Blow-off device 32.660 (p.525), Vacuum switch 20.040 (p.689), Vacuum switch 20.041 (p.689), Silencer 72.000 (p.578), Silencer 72.028 (p.577)



When ordering please specify

Type + Nozzle diameter + Vacuum output = Item number

Example: EIL.07-M6

(Mini ejector EIL., nozzle diameter 0.7 mm, with vacuum output M6-female)

1.: Type	2.: Nozzle diameter	3.: Vacuum output		
EIL.	05	Ø 0.5 mm	M6	M6
	07	Ø 0.7 mm	A18	G1/8-male
			A14	G1/4-male
	09	Ø 0.9 mm	I18	G1/8-female
			I14	G1/4-female

Type + Nozzle diameter + Vacuum output + Silencer = Item number

Example: EIL.12-M10G

(Inline ejector EIL, nozzle diameter: 1.2 mm, vacuum output M10x125 male thread with silencer 72.000)

1.: Type	2.: Nozzle diameter	3.: Vacuum output		4.: Silencer	
EIL.	10	Ø 1 mm	A14	G1/4-male	G 72.000 (closed diffusor silencer)
	12	Ø 1.2 mm	M10	M10x125-male	O 72.028 (open silencer)
	14	Ø 1.4 mm			

Handling of wooden plates

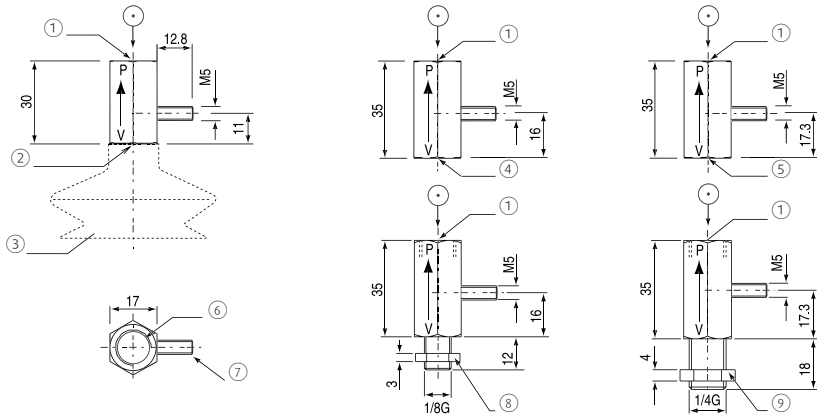

Illustration with check valve 32.638 with blow-off function and vacuum cup 102.070.234.9 for wood handling

Continued on the next page →



Dimensions



EIL.05 | EIL.07 | EIL.09

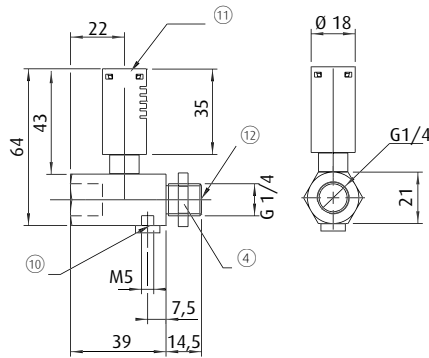

EIL.10 | EIL.12 | EIL.14

- ① = Compressed air input G1/4, depth 10 mm
- ② = Vacuum output M6, depth 6 mm
- ③ = Vacuum cup example
- ④ = Vacuum output G1/4-female, depth 7.5 mm
- ⑤ = Vacuum output G1/8-female, depth 10 mm
- ⑥ = Compressed air
- ⑦ = Exhaust
- ⑧ = Hex nut (SW14)
- ⑨ = Hex nut (SW19)
- ⑩ = Blow-off or vacuum switch connection
- ⑪ = Silencers
- ⑫ = Vacuum

Diagrams

> Vacuum level against feed pressure

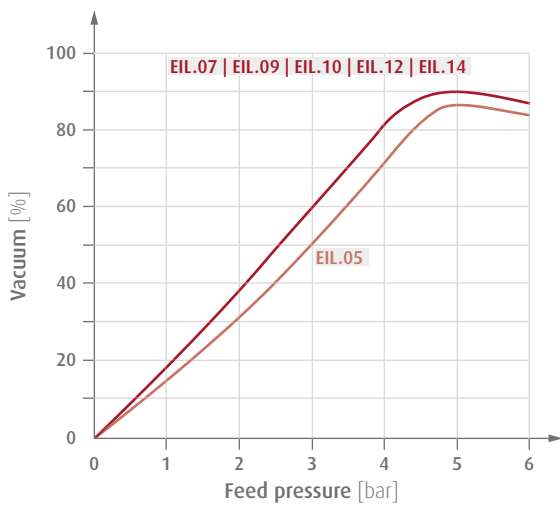

> Air consumption against feed pressure

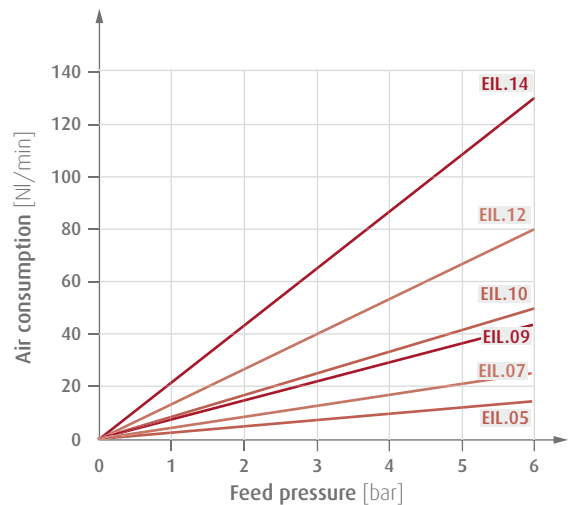



Diagrams

> Suction power against feed pressure

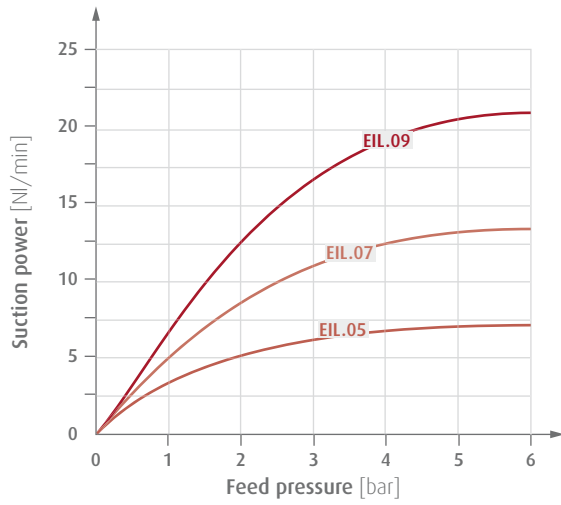

> Suction power against feed pressure

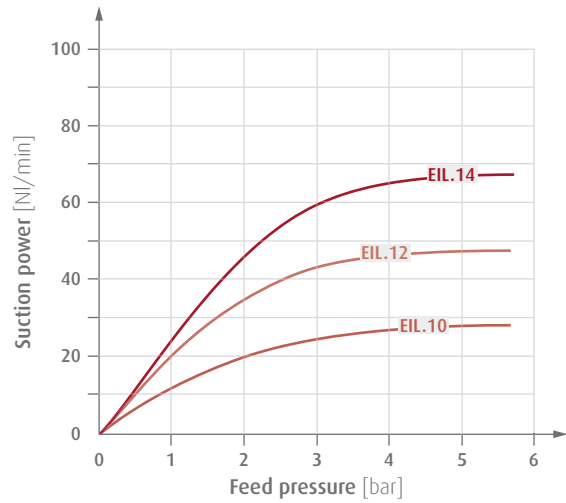

> Suction power against vacuum

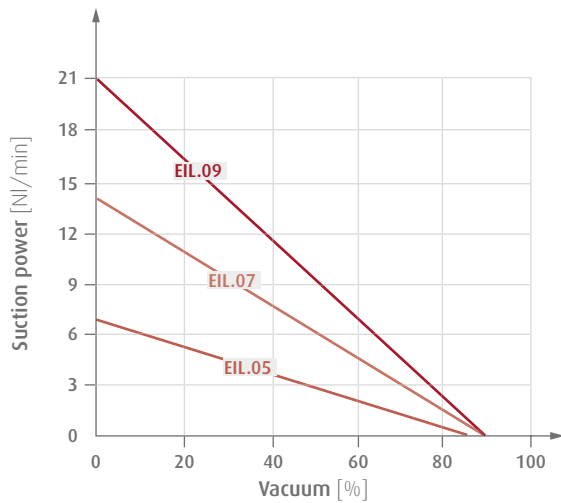

> Suction power against vacuum

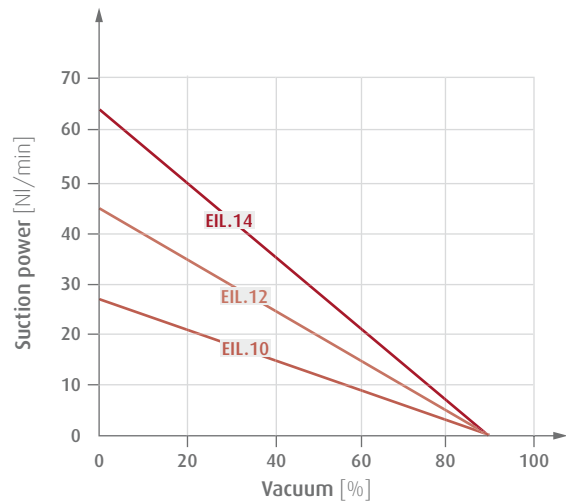

Evacuation time [sec.] for 1 liter at vacuum level

Item no.	10 %	20 %	30 %	40 %	50 %	60 %	70 %	80 %	85 %
EIL.05	0.92	1.96	3.18	4.63	6.38	8.79	12.17	18.96	27.39
EIL.07	0.46	0.98	1.58	2.28	3.13	4.27	5.8	8.55	11.01
EIL.09	0.31	0.65	1.05	1.52	2.09	2.85	3.87	5.7	7.34
EIL.10	0.24	0.51	0.82	1.18	1.62	2.21	3.01	4.43	5.71
EIL.12	0.14	0.3	0.49	0.71	0.97	1.33	1.81	2.66	3.42
EIL.14	0.1	0.21	0.34	0.5	0.68	0.93	1.27	1.85	2.44



Inline ejectors EIL - accessories

Ejector bracket



Technical data

Item no.	Weight [g]
EIL.05-HO	2
EIL.07-HO	2

Dimensions

B [mm]	F [mm]	J [mm]
33	9	15
39	10	20

Dimensions

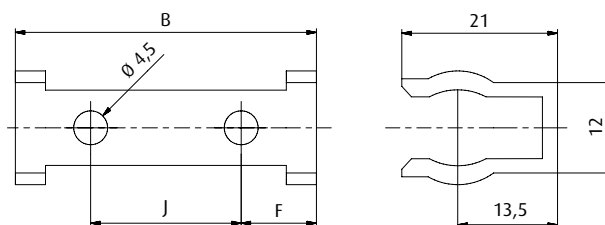



Blow-off device for ejectors



32.660 enables blow-off with check valve 32.638

Product Description

- > Short cycle times thanks to direct connection to ejectors via M5 external thread
- > Suitable e.g. for inline ejectors EIL, expandable

Notes

- > Blow-off device is part of check valve 32.638 with blow-off function

Technical data

Item no.	Plug connection [mm]	Blow-off capacity at 5 bar [NI/min]
32.660	6	100

Dimensions

G	∅ D [mm]	F [mm]	J [mm]	L [mm]
M5	14.2	4.2	16.75	28.1

Dimensions

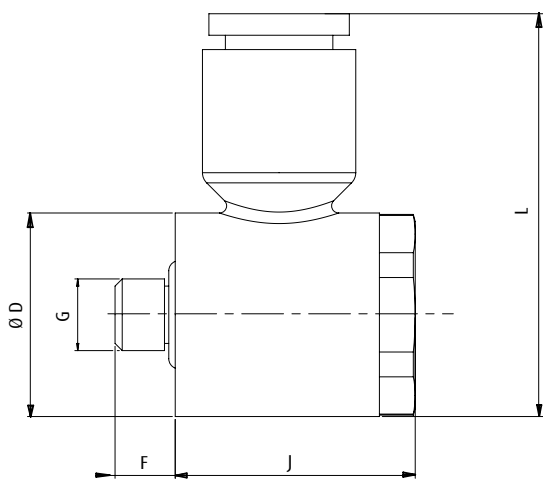

Wiring diagram

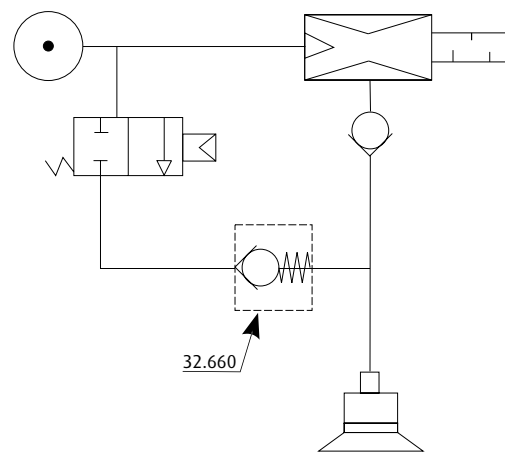



FIPA Basic and Heavy-duty ejectors

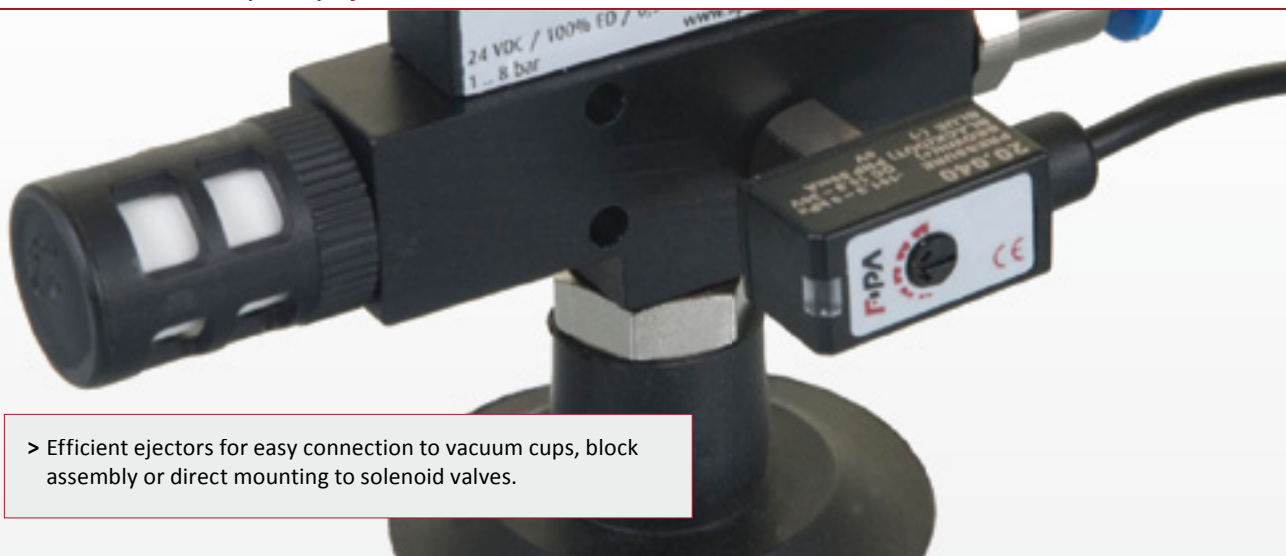

> Efficient ejectors for easy connection to vacuum cups, block assembly or direct mounting to solenoid valves.



Base ejectors with graded blow-off

- > Very short cycle times thanks to fast-reacting micro valve
- > Ideally suited for robotic applications, such as Delta robots (e.g. FlexPickers)

> See page 528



Ejector boxes EBO

- > Rectangular design for space-saving parallel connection in centralised or decentralised vacuum systems
- > For handling dense workpieces (max. vacuum level 93 %): Index H
- > For handling porous workpieces (higher suction power, max. vacuum level 68 %): Index L
- > Special compressed air-saving operation for handling dense workpieces at only 3.5 bar (max. vacuum level 90 %): Index P

> See page 530



Base ejectors EBA

- > For handling dense workpieces (max. vacuum level 93 %): Index H
- > For handling porous workpieces (higher suction power, max. vacuum level 68 %): Index L
- > Special compressed air-saving operation for handling dense workpieces at only 3.5 bar (max. vacuum level 90 %): Index P

> See page 533



Base ejectors EBM

- > Easy installation directly on the vacuum cup
- > Small dimensions for installation where space is limited
- > Miniature silencer that can be dismantled for fast servicing and short downtimes

> See page 541



FIPA Base and Heavy-duty ejectors



Heavy-duty ejectors 65.102A - 65.130

- > Robust and compact aluminium housing
- > Compensation of compressed air fluctuations between 3 to 6 bar
- > Additional inlet for blow-off for short cycle times or vacuum switch connection for process monitoring (65.111, 65.130)
- > Rectangular design for space-saving parallel connection in centralised or decentralised vacuum systems

> See page 544

Examples of use

- > Handling of lightweight parts
- > Pick & place applications
- > Separation systems in sheet metal handling or plastic manufacturing
- > Handling of electrical components

Functional principle

Ejectors work according to the Venturi principle and generate vacuum **V** from compressed air **P**. Vacuum is created in the subsequent chamber as a result of the high flow speed to the primary nozzle. "Used" compressed air and suctioned air leave the ejector through the secondary nozzle **Ex**.

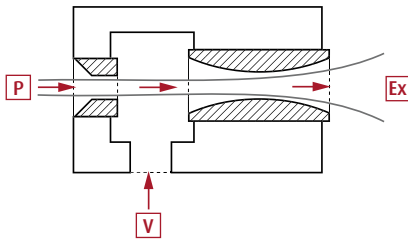



Base ejectors with graded blow-off

NEW

VERY SHORT RESPONSE TIME, SAFE AND GENTLE PRODUCT RELEASE



Example: Ejector EBA.08H.2-A with digital mini vacuum switch 20.040, closed diffusor silencer 72.000 and flat vacuum cup \varnothing 40 mm

Product Description

- > Small and very light for installation directly on vacuum cups for fast vacuum build-up and short gripping times
- > Blow-off pulse from a fast-reacting micro valve enables very short cycle times
- > Graded blow-off boost effect: Initially the blow-off is supported by ambient air, for placement that is both quick and gentle
- > Robust design and long service life of > 100 million switching cycles
- > M5 connection for digital mini vacuum switch to ensure reliable process monitoring
- > Ideally suited for robotic applications with very short cycles such as Delta robots (e.g. FlexPickers)

Ordering notes

- > Included in delivery: control cable 20.550, length 1,5 meter, 2-wire, free end

Technical data

Item no.	EBA.08H.2-A
Nozzle diameter [mm]	0.8
Optimal feed pressure [bar]	5
Max. feed pressure [bar]	8
Final vacuum [%]	85
Suction power at 5 bar [NI/min]	25
Air consumption at 5 bar [NI/min]	30
Flow rate solenoid valve [NI/min]	15
Blow-off volumes of flow [NI/min]	110 - 45
Power-on time solenoid valve (ED) [%]	100
Power-on/ -off time solenoid valve [ms]	5
Power consumption solenoid valve [W]	0.9
Protection class	IP40
Operating temperature [°C]	-10 - 50
Weight [g]	35
Suitable accessories	Connector cable 20.550 (p.717), Vacuum switch 20.040 (p.689), Vacuum switch 20.041 (p.689), Silencer 72.000 (p.578), Silencer 72.028 (p.577)

Control cable 20.550



Cable assignment: red (+), black (-)



Graded blow-off with boost-effect

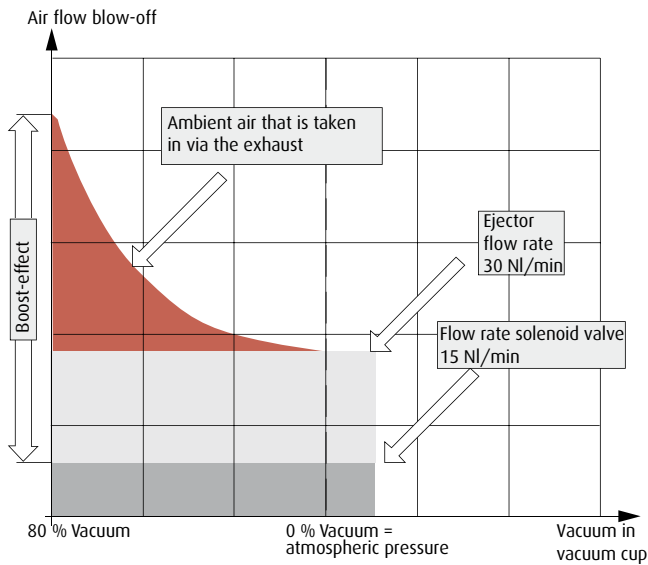

Evacuation / Blow-off time

Evacuation / Blow-off time 1 liter volume up to % vacuum / atmospheric pressure [sec.]			Evacuation / Blow-off time: example with Ø 30 mm flat suction cups, volume 1.7 cm ³ up to % vacuum / atmospheric pressure [ms]		
0 → 50 % / 50 % → 0	0 → 60 % / 60 % → 0	0 → 70 % / 70 % → 0	0 → 50 % / 50 % → 0	0 → 60 % / 60 % → 0	0 → 70 % / 70 % → 0
1.8 / 0.5	2.5 / 0.56	3.9 / 0.61	3 / < 1	4 / < 1	7 / 1

Dimensions

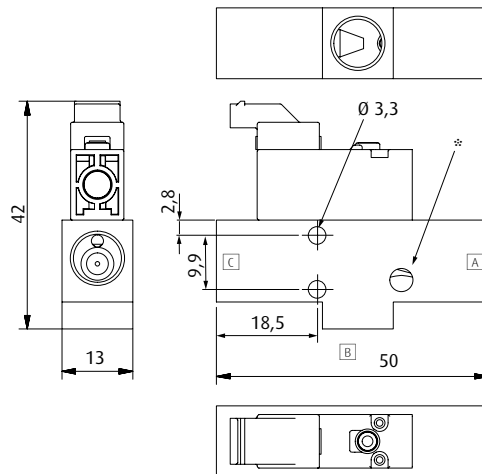

A = Compressed air connection G1/8-female
 B = Vacuum connection G1/8-female
 C = Exhaust outlet G1/8-female
 * = M5 connection for vacuum switches



Ejector boxes EBO

Compressed air and vacuum connection via quick fittings, exhaust via rectangular silencer



Series "-S" with mechanical vacuum switch

V = Vacuum connection
 P = Compressed air connection
 Ex = Exhaust outlet

Product Description

- > High suction power for fast evacuation and short gripping time
- > Easy installation directly in the vacuum line
- > Rectangular design enables space-conserving parallel mounting of several ejector boxes
- > Replaceable silencer filter element
- > "-S" series with mechanical / electrical vacuum switch
 - Monitoring of vacuum circuits for high process reliability
 - NO / NC switching function

Notes

"-S" series with mechanical / electrical vacuum switch:

- > Factory setting: -534 mbar
- > Contact capacity: 3 A at 250 V
- > Regulating range: -200 to -667 mbar
- > Repeat accuracy: ± 50 mbar
- > Hysteresis: -200 mbar

Ordering notes

- > Index H: Ejectors for dense products (max. vacuum degree 90 %)
- > Index L: Ejectors for porous products, resp. in case of higher leakage (increased suction, max. vacuum degree 68 %)
- > Index P: Ejectors designed for lower feed pressure (max. vacuum degree 90 %)

Technical data

Item no.	Nozzle diameter [mm]	Optimal feed pressure [bar]	Final vacuum [%]	Suction power [Nl/min]	Air consumption [Nl/min]	Operating temperature [°C]	Weight [g]	Suitable filter and silencer set
EBO.05H.4	0.5	5	90	7	11.5	0 - 60	18	72.105
EBO.07H.1	0.7	5	93	13	23	0 - 60	18.5	72.105
EBO.10H.1	1	5	93	28	46	0 - 60	18.5	72.105
EBO.12H.1	1.2	5	93	38	70	0 - 60	18	72.105
EBO.05L.4	0.5	5	68	12	11.5	0 - 60	18	72.105
EBO.07L.1	0.7	5	68	26	23	0 - 60	18.5	72.105
EBO.10L.1	1	5	68	42	46	0 - 60	17.5	72.105
EBO.07P.1	0.7	3.5	90	10.5	17	0 - 60	18.5	72.105
EBO.10P.1	1	3.5	90	21	34	0 - 60	18.5	72.105
EBO.12P.1	1.2	3.5	90	27	47	0 - 60	18	72.105
EBO.05H.4-S	0.5	5	90	7	11.5	0 - 60	46.5	72.105
EBO.07H.1-S	0.7	5	93	13	23	0 - 60	46	72.105
EBO.10H.1-S	1	5	93	28	46	0 - 60	47	72.105
EBO.12H.1-S	1.2	5	93	38	70	0 - 60	47.5	72.105
EBO.05L.4-S	0.5	5	68	12	11.5	0 - 60	46.5	72.105
EBO.07L.1-S	0.7	5	68	26	23	0 - 60	48	72.105
EBO.10L.1-S	1	5	68	42	46	0 - 60	46.5	72.105
EBO.07P.1-S	0.7	3.5	90	10.5	17	0 - 60	48.5	72.105
EBO.10P.1-S	1	3.5	90	21	34	0 - 60	48.5	72.105
EBO.12P.1-S	1.2	3.5	90	27	47	0 - 60	47.5	72.105



Dimensions

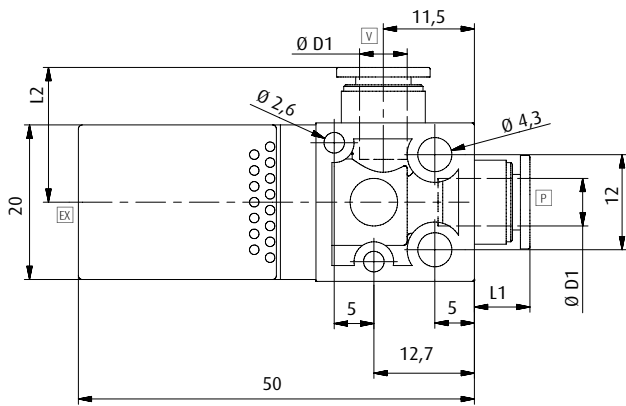

EBO.05H.4 | EBO.07H.1 | EBO.10H.1 | EBO.12H.1 | EBO.05L.4 |
EBO.07L.1 | EBO.10L.1 | EBO.07P.1 | EBO.10P.1 | EBO.12P.1

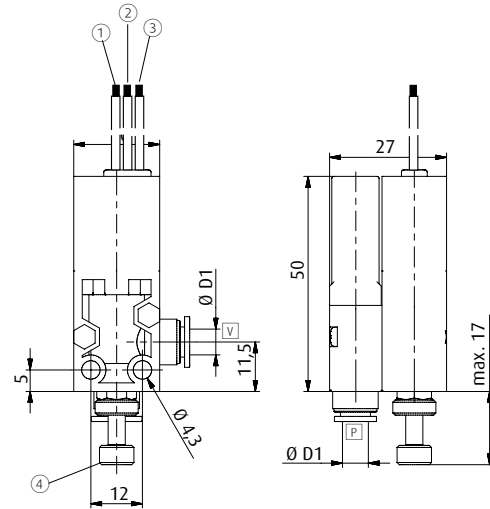

EBO.05H.4-S | EBO.07H.1-S | EBO.10H.1-S | EBO.12H.1-S |
EBO.05L.4-S | EBO.07L.1-S | EBO.10L.1-S | EBO.07P.1-S |
EBO.10P.1-S | EBO.12P.1-S

P = Compressed air side with tubing connection V = Vacuum side with tubing connection EX = Exhaust outlet ① = White ② = Red (NC)
③ = Black (NO) ④ = knurled screw

Item no.	Ø D1 [mm]	L1 [mm]	L2 [mm]
EBO.05H.4	4	6.6	6.6
EBO.07H.1	6	7	7
EBO.10H.1	6	7	7
EBO.12H.1	6	7	7
EBO.05L.4	4	6.6	6.6
EBO.07L.1	6	7	7
EBO.10L.1	6	7	7
EBO.07P.1	6	7	7
EBO.10P.1	6	7	7
EBO.12P.1	6	7	7
EBO.05H.4-S	4	--	--
EBO.07H.1-S	6	--	--
EBO.10H.1-S	6	--	--
EBO.12H.1-S	6	--	--
EBO.05L.4-S	4	--	--
EBO.07L.1-S	6	--	--
EBO.10L.1-S	6	--	--
EBO.07P.1-S	6	--	--
EBO.10P.1-S	6	--	--
EBO.12P.1-S	6	--	--

Continued on the next page →



Suction power [NI/min] at vacuum level

Item no.	0 %	10 %	20 %	30 %	40 %	50 %	60 %	70 %	80 %	90 %
EBO.05H.4	7	6.2	5.4	4.6	3.8	3	2.2	1.5	0.7	--
EBO.07H.1	13	11.6	10.1	8.8	7.5	5.9	4.2	3	1.6	0.4
EBO.10H.1	28	25	22	18.9	15.9	12.9	9.9	6.9	3.9	0.9
EBO.12H.1	38	33.9	29.8	25.7	21.6	17.5	13.4	9.3	5.3	1.2
EBO.05L.4	12	10.8	9	7.5	5.5	4	2.5	0.8	--	--
EBO.07L.1	26	22	18.2	14	10	6.3	2.4	--	--	--
EBO.10L.1	42	35.6	29.3	22.9	16.5	10.2	3.8	--	--	--
EBO.07P.1	10.5	9.3	8.1	7	5.8	4.6	3.5	2.2	1.1	--
EBO.10P.1	21	18.7	16.4	14	11.8	9.5	7.1	4.8	2.5	0.2
EBO.12P.1	27	24	21	18.1	15.1	12	9.2	6.2	3.3	0.3
EBO.05H.4-S	7	6.2	5.4	4.6	3.8	3	2.2	1.5	0.7	--
EBO.07H.1-S	13	11.6	10.1	8.8	7.5	5.9	4.2	3	1.6	0.4
EBO.10H.1-S	28	25	22	18.9	15.9	12.9	9.9	6.9	3.9	0.9
EBO.12H.1-S	38	33.9	29.8	25.7	21.6	17.5	13.4	9.3	5.3	1.2
EBO.05L.4-S	12	10.8	9	7.5	5.5	4	2.5	0.8	--	--
EBO.07L.1-S	26	22	18.2	14	10	6.3	2.4	--	--	--
EBO.10L.1-S	42	35.6	29.3	22.9	16.5	10.2	3.8	--	--	--
EBO.07P.1-S	10.5	9.3	8.1	7	5.8	4.6	3.5	2.2	1.1	--
EBO.10P.1-S	21	18.7	16.4	14	11.8	9.5	7.1	4.8	2.5	0.2
EBO.12P.1-S	27	24	21	18.1	15.1	12	9.2	6.2	3.3	0.3

Diagrams see pages 542 - 543



Base ejectors EBA for vacuum cups

Compressed air connection via quick fittings, vacuum connection via R-threads, exchangeable silencer



Series with fixed air connection



Series with rotatable, angular air connection

☐ = Vacuum connection ☐ = Compressed air connection ☐ = Exhaust outlet

Product Description

- > High suction power for short gripping time
- > Easy installation directly on the vacuum cup
- > Robust aluminium body
- > Replaceable silencer filter element for short downtimes

Ordering notes

- > Index H: Ejectors for dense products (max. vacuum degree 93 %)
- > Index L: Ejectors for porous products, resp. in case of higher leakage (increased suction power, max. vacuum degree 68 %)
- > Index P: Ejectors designed for lower feed pressure (max. vacuum degree 90 %)
- > Index -W: Order code for rotatable, angular air connection

Technical data

Item no.	Nozzle diameter [mm]	Optimal feed pressure [bar]	Final vacuum [%]	Suction power [N/min]	Air consumption [N/min]	Operating temperature [°C]	Weight [g]	Suitable Silencer elements
EBA.07H.1	0.7	5	93	13	23	5 - 50	31.5	72.102
EBA.07H.2	0.7	5	93	13	23	5 - 50	31.5	72.102
EBA.10H.1	1	5	93	28	46	5 - 50	31.5	72.102
EBA.10H.2	1	5	93	28	46	5 - 50	31.5	72.102
EBA.12H.1	1.2	5	93	38	70	5 - 50	31.5	72.102
EBA.12H.2	1.2	5	93	38	70	5 - 50	31.5	72.102
EBA.15H.1	1.5	5	93	63	100	5 - 50	87	72.103
EBA.15H.2	1.5	5	93	63	100	5 - 50	88	72.103
EBA.20H.1	2	5	93	110	200	5 - 50	92.5	72.104
EBA.15L.1	1.5	5	68	95	100	5 - 50	85	72.103
EBA.15L.2	1.5	5	68	95	100	5 - 50	86	72.103
EBA.20L.1	2	5	68	180	200	5 - 50	88	72.104
EBA.07P.1	0.7	5	90	10.5	17	5 - 50	31.5	72.102
EBA.07P.2	0.7	5	90	10.5	17	5 - 50	31.5	72.102
EBA.10P.1	1	5	90	21	34	5 - 50	31.5	72.102
EBA.10P.2	1	5	90	21	34	5 - 50	31.5	72.102
EBA.12P.1	1.2	5	90	27	47	5 - 50	31.5	72.102
EBA.12P.2	1.2	5	90	27	47	5 - 50	31.5	72.102
EBA.15P.1	1.5	5	90	42	70	5 - 50	87.5	72.103
EBA.15P.2	1.5	5	90	42	70	5 - 50	88.5	72.103

Continued on the next page →



Vacuum generation | Base ejectors

Base ejectors EBA for vacuum cups

Technical data

Item no.	Nozzle diameter [mm]	Optimal feed pressure [bar]	Final vacuum [%]	Suction power [Nl/min]	Air consumption [Nl/min]	Operating temperature [°C]	Weight [g]	Suitable Silencer elements
EBA.20P.1	2	5	90	84	150	5 - 50	94	72.104
EBA.07H.1-W	0.7	5	93	13	23	5 - 50	31.5	72.102
EBA.07H.2-W	0.7	5	93	13	23	5 - 50	34	72.102
EBA.10H.1-W	1	5	93	28	46	5 - 50	31.5	72.102
EBA.10H.2-W	1	5	93	28	46	5 - 50	34	72.102
EBA.12H.1-W	1.2	5	93	38	70	5 - 50	31.5	72.102
EBA.12H.2-W	1.2	5	93	38	70	5 - 50	34	72.102
EBA.15H.1-W	1.5	5	93	63	100	5 - 50	85.5	72.103
EBA.15H.2-W	1.5	5	93	63	100	5 - 50	86.5	72.103
EBA.20H.1-W	2	5	93	110	200	5 - 50	95	72.104
EBA.15L.1-W	1.5	5	68	95	100	5 - 50	84	72.103
EBA.15L.2-W	1.5	5	68	95	100	5 - 50	85	72.103
EBA.20L.1-W	2	5	68	180	200	5 - 50	90.5	72.104
EBA.07P.1-W	0.7	5	90	10.5	17	5 - 50	31.5	72.102
EBA.07P.2-W	0.7	5	90	10.5	17	5 - 50	34	72.102
EBA.10P.1-W	1	5	90	21	34	5 - 50	31.5	72.102
EBA.10P.2-W	1	5	90	21	34	5 - 50	34	72.102
EBA.12P.1-W	1.2	5	90	27	47	5 - 50	31.5	72.102
EBA.12P.2-W	1.2	5	90	27	47	5 - 50	34	72.102
EBA.15P.1-W	1.5	5	90	42	70	5 - 50	86.5	72.103
EBA.15P.2-W	1.5	5	90	42	70	5 - 50	87.5	72.103
EBA.20P.1-W	2	5	90	84	150	5 - 50	96.5	72.104

Dimensions

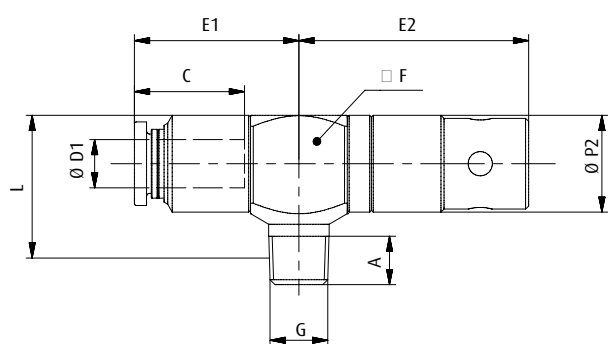

EBA.07H.1 - EBA20P.1

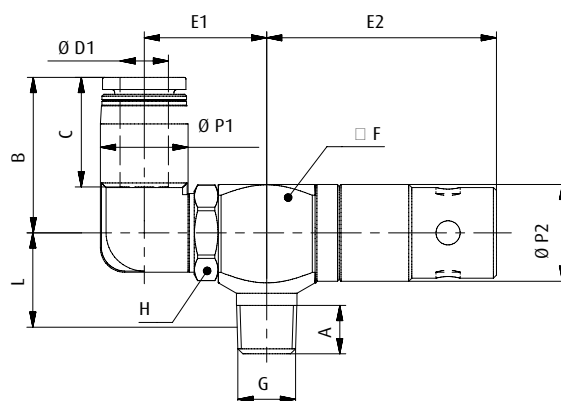

EBA.07H.1-W - EBA20P.1-W



Item no.	G	Ø D1 [mm]	A [mm]	B [mm]	C [mm]	E1 [mm]	E2 [mm]	□ F [mm]	H [mm]	L [mm]	Ø P1 [mm]	Ø P2 [mm]
EBA.07H.1	R1/8	6	8	--	17	24.5	38	16	--	16	--	16
EBA.07H.2	R1/8	8	8	--	18.5	28	38	16	--	16	--	16
EBA.10H.1	R1/8	6	8	--	17	24.5	38	16	--	16	--	16
EBA.10H.2	R1/8	8	8	--	18.5	28	38	16	--	16	--	16
EBA.12H.1	R1/8	6	8	--	17	24.5	38	16	--	16	--	16
EBA.12H.2	R1/8	8	8	--	18.5	28	38	16	--	16	--	16
EBA.15H.1	R1/4	8	11	--	18	29.5	75	22	--	21	--	24
EBA.15H.2	R3/8	8	12	--	18	29.5	75	22	--	20.5	--	24
EBA.20H.1	R1/4	10	11	--	20	31	75	22	--	21	--	24
EBA.15L.1	R1/4	8	11	--	18	29.5	75	22	--	21	--	24
EBA.15L.2	R3/8	8	12	--	18	29.5	75	22	--	20.5	--	24
EBA.20L.1	R1/4	10	11	--	20	31	75	22	--	21	--	24
EBA.07P.1	R1/8	6	8	--	17	24.5	38	16	--	16	--	16
EBA.07P.2	R1/8	8	8	--	18.5	28	38	16	--	16	--	16
EBA.10P.1	R1/8	6	8	--	17	24.5	38	16	--	16	--	16
EBA.10P.2	R1/8	8	8	--	18.5	28	38	16	--	16	--	16
EBA.12P.1	R1/8	6	8	--	17	24.5	38	16	--	16	--	16
EBA.12P.2	R1/8	8	8	--	18.5	28	38	16	--	16	--	16
EBA.15P.1	R1/4	8	11	--	18	29.5	75	22	--	21	--	24
EBA.15P.2	R3/8	8	12	--	18	29.5	75	22	--	20.5	--	24
EBA.20P.1	R1/4	10	11	--	20	31	75	22	--	21	--	24
EBA.07H.1-W	R1/8	6	8	23	17	19	38	16	14	16	12.5	16
EBA.07H.2-W	R1/8	8	8	24	18.5	20	38	16	14	16	14.5	16
EBA.10H.1-W	R1/8	6	8	23	17	19	38	16	14	16	12.5	16
EBA.10H.2-W	R1/8	8	8	24	18.5	20	38	16	14	16	14.5	16
EBA.12H.1-W	R1/8	6	8	23	17	19	38	16	14	16	12.5	16
EBA.12H.2-W	R1/8	8	8	24	18.5	20	38	16	14	16	14.5	16
EBA.15H.1-W	R1/4	8	11	26	18.5	23	75	22	19	21	14.5	24
EBA.15H.2-W	R3/8	8	12	26	18.5	23	75	22	19	20.5	14.5	24
EBA.20H.1-W	R1/4	10	11	30	21	25.5	75	22	19	21	17.5	24
EBA.15L.1-W	R1/4	8	11	26	18.5	23	75	22	19	21	14.5	24
EBA.15L.2-W	R3/8	8	12	26	18.5	23	75	22	19	20.5	14.5	24
EBA.20L.1-W	R1/4	10	11	30	21	25.5	75	22	19	21	17.5	24
EBA.07P.1-W	R1/8	6	8	23	17	19	38	16	14	16	12.5	16
EBA.07P.2-W	R1/8	8	8	24	18.5	20	38	16	14	16	14.5	16
EBA.10P.1-W	R1/8	6	8	23	17	19	38	16	14	16	12.5	16
EBA.10P.2-W	R1/8	8	8	24	18.5	20	38	16	14	16	14.5	16
EBA.12P.1-W	R1/8	6	8	23	17	19	38	16	14	16	12.5	16
EBA.12P.2-W	R1/8	8	8	24	18.5	20	38	16	14	16	14.5	16
EBA.15P.1-W	R1/4	8	11	26	18.5	23	75	22	19	21	14.5	24
EBA.15P.2-W	R3/8	8	12	26	18.5	23	75	22	19	20.5	14.5	24
EBA.20P.1-W	R1/4	10	11	30	21	25.5	75	22	19	21	17.5	24

Continued on the next page →



Vacuum generation | Base ejectors

Base ejectors EBA for vacuum cups

Suction power [NI/min] at vacuum level

Item no.	0 %	10 %	20 %	30 %	40 %	50 %	60 %	70 %	80 %	90 %
EBA.07H.1	13	11.6	10.1	8.8	7.5	5.9	4.2	3	1.6	0.4
EBA.07H.2	13	11.6	10.1	8.8	7.5	5.9	4.2	3	1.6	0.4
EBA.10H.1	28	25	22	18.9	15.9	12.9	9.9	6.9	3.9	0.9
EBA.10H.2	28	25	22	18.9	15.9	12.9	9.9	6.9	3.9	0.9
EBA.12H.1	38	33.9	29.8	25.7	21.6	17.5	13.4	9.3	5.3	1.2
EBA.12H.2	38	33.9	29.8	25.7	21.6	17.5	13.4	9.3	5.3	1.2
EBA.15H.1	63	56.2	49.4	42.6	35.9	29.1	22.3	15.6	8.8	2
EBA.15H.2	63	56.2	49.4	42.6	35.9	29.1	22.3	15.6	8.8	2
EBA.20H.1	110	98.1	86.3	74.5	62.7	50.8	39	27.2	15.3	3.5
EBA.15L.1	95	80.6	66.2	51.8	37.4	23	8.6	--	--	--
EBA.15L.2	95	80.6	66.2	51.8	37.4	23	8.6	--	--	--
EBA.20L.1	180	153.1	126.3	99.4	72.5	45.6	18.8	--	--	--
EBA.07P.1	10.5	9.3	8.1	7	5.8	4.6	3.5	2.2	1.1	--
EBA.07P.2	10.5	9.3	8.1	7	5.8	4.6	3.5	2.2	1.1	--
EBA.10P.1	21	18.7	16.4	14	11.8	9.5	7.1	4.8	2.5	0.2
EBA.10P.2	21	18.7	16.4	14	11.8	9.5	7.1	4.8	2.5	0.2
EBA.12P.1	27	24	21	18.1	15.1	12	9.2	6.2	3.3	0.3
EBA.12P.2	27	24	21	18.1	15.1	12	9.2	6.2	3.3	0.3
EBA.15P.1	37	32.9	28.8	24.8	20.7	16.6	12.6	8.5	4.5	0.4
EBA.15P.2	37	32.9	28.8	24.8	20.7	16.6	12.6	8.5	4.5	0.4
EBA.20P.1	84	74.7	65.5	56.3	47	37.8	28.6	19.4	10.1	0.9
EBA.07H.1-W	13	11.6	10.1	8.8	7.5	5.9	4.2	3	1.6	0.4
EBA.07H.2-W	13	11.6	10.1	8.8	7.5	5.9	4.2	3	1.6	0.4
EBA.10H.1-W	28	25	22	18.9	15.9	12.9	9.9	6.9	3.9	0.9
EBA.10H.2-W	28	25	22	18.9	15.9	12.9	9.9	6.9	3.9	0.9
EBA.12H.1-W	38	33.9	29.8	25.7	21.6	17.5	13.4	9.3	5.3	1.2
EBA.12H.2-W	38	33.9	29.8	25.7	21.6	17.5	13.4	9.3	5.3	1.2
EBA.15H.1-W	63	56.2	49.4	42.6	35.9	29.1	22.3	15.6	8.8	2
EBA.15H.2-W	63	56.2	49.4	42.6	35.9	29.1	22.3	15.6	8.8	2
EBA.20H.1-W	110	98.1	86.3	74.5	62.7	50.8	39	27.2	15.3	3.5
EBA.15L.1-W	95	80.6	66.2	51.8	37.4	23	8.6	--	--	--
EBA.15L.2-W	95	80.6	66.2	51.8	37.4	23	8.6	--	--	--
EBA.20L.1-W	180	153.1	126.3	99.4	72.5	45.6	18.8	--	--	--
EBA.07P.1-W	10.5	9.3	8.1	7	5.8	4.6	3.5	2.2	1.1	--
EBA.07P.2-W	10.5	9.3	8.1	7	5.8	4.6	3.5	2.2	1.1	--
EBA.10P.1-W	21	18.7	16.4	14	11.8	9.5	7.1	4.8	2.5	0.2
EBA.10P.2-W	21	18.7	16.4	14	11.8	9.5	7.1	4.8	2.5	0.2
EBA.12P.1-W	27	24	21	18.1	15.1	12	9.2	6.2	3.3	0.3
EBA.12P.2-W	27	24	21	18.1	15.1	12	9.2	6.2	3.3	0.3
EBA.15P.1-W	37	32.9	28.8	24.8	20.7	16.6	12.6	8.5	4.5	0.4
EBA.15P.2-W	37	32.9	28.8	24.8	20.7	16.6	12.6	8.5	4.5	0.4
EBA.20P.1-W	84	74.7	65.5	56.3	47	37.8	28.6	19.4	10.1	0.9

Diagrams see pages 542 - 543



Base ejectors EBA for solenoid valves

Compressed air connection via R-threads, vacuum connection via quick fittings



Series with exhaust outlet via silencer



Series with exhaust outlet via quick fitting

☑ = Vacuum connection ☐ = Compressed air connection ☒ = Exhaust outlet

Product Description

- > Suitable for direct fitting to solenoid valves
- > High suction power for short gripping times
- > Flexible installation thanks to rotatable, angled vacuum connection
- > Replaceable silencer for fast servicing and short downtimes
- > Avoidance of product contamination with exhaust outlet through quick fitting (index MV-I)

Ordering notes

- > Index H: Ejectors for dense products (max. vacuum degree 93 %)
- > Index L: Ejectors for porous products, resp. in case of higher leakage (increased suction power, max. vacuum degree 68 %)
- > Index P: Ejectors designed for lower feed pressure (max. vacuum degree 90 %)
- > Index MV-I: Order code with exhaust outlet via quick fitting: Example: EBA.10H.1-MV-I

Technical data

Item no.	Nozzle diameter [mm]	Optimal feed pressure [bar]	Final vacuum [%]	Suction power [Nl/min]	Air consumption [Nl/min]	Operating temperature [°C]	Weight [g]	Suitable silencer elements
EBA.05H.1-MV	0.5	5	90	7	11.5	0 - 60	13	SEE0802
EBA.05H.2-MV	0.5	5	90	7	11.5	0 - 60	36.5	SE01
EBA.07H.1-MV	0.7	5	93	13	23	0 - 60	37	SE01
EBA.10H.1-MV	1	5	93	28	46	0 - 60	36.5	SE01
EBA.10H.2-MV	1	5	93	28	46	0 - 60	38	SE01
EBA.12H.1-MV	1.2	5	93	38	70	0 - 60	36.5	SE01
EBA.12H.2-MV	1.2	5	93	38	70	0 - 60	37.5	SE01
EBA.15H.1-MV	1.5	5	93	63	100	0 - 60	77	SE02
EBA.05L.1-MV	0.5	5	65	12	11.5	0 - 60	13	SEE0802
EBA.05L.2-MV	0.5	5	65	11	11.5	0 - 60	36.5	SE01
EBA.07L.1-MV	0.7	5	68	26	23	0 - 60	37	SE01
EBA.07L.2-MV	0.7	5	68	26	23	0 - 60	38.5	SE01
EBA.10L.1-MV	1	5	68	42	46	0 - 60	36	SE01
EBA.10L.2-MV	1	5	68	42	46	0 - 60	37.5	SE01
EBA.15L.1-MV	1.5	5	68	95	100	0 - 60	75	SE02
EBA.07P.1-MV	0.7	3.5	90	10.5	17	0 - 60	36.5	SE01
EBA.10P.1-MV	1	3.5	90	21	34	0 - 60	37	SE01
EBA.10P.2-MV	1	3.5	90	21	34	0 - 60	38.5	SE01

Continued on the next page →



Vacuum generation | Base ejectors

Base ejectors EBA for solenoid valves

Technical data

Item no.	Nozzle diameter [mm]	Optimal feed pressure [bar]	Final vacuum [%]	Suction power [Nl/min]	Air consumption [Nl/min]	Operating temperature [°C]	Weight [g]	Suitable Silencer elements
EBA.12P.1-MV	1.2	3.5	90	27	47	0 - 60	36.5	SE01
EBA.12P.2-MV	1.2	3.5	90	27	47	0 - 60	38	SE01
EBA.15P.1-MV	1.5	3.5	90	37	74	0 - 60	78	SE02
EBA.05H.1-MV-I	0.5	5	90	7	11.5	0 - 60	18	--
EBA.05H.2-MV-I	0.5	5	90	7	11.5	0 - 60	44.5	--
EBA.07H.1-MV-I	0.7	5	90	13	23	0 - 60	45.5	--
EBA.10H.1-MV-I	1	5	93	28	46	0 - 60	44.5	--
EBA.10H.2-MV-I	1	5	93	28	46	0 - 60	45.5	--
EBA.12H.1-MV-I	1.2	5	93	38	70	0 - 60	44	--
EBA.12H.2-MV-I	1.2	5	93	38	70	0 - 60	46	--
EBA.15H.1-MV-I	1.5	5	93	63	100	0 - 60	92	--
EBA.05L.1-MV-I	0.5	5	65	12	11.5	0 - 60	18	--
EBA.05L.2-MV-I	0.5	5	65	11	11.5	0 - 60	44.5	--
EBA.07L.1-MV-I	0.7	5	68	26	23	0 - 60	45	--
EBA.07L.2-MV-I	0.7	5	68	26	23	0 - 60	46	--
EBA.10L.1-MV-I	1	5	68	42	46	0 - 60	44	--
EBA.10L.2-MV-I	1	5	68	42	46	0 - 60	45	--
EBA.15L.1-MV-I	1.5	5	68	95	100	0 - 60	89.4	--
EBA.07P.1-MV-I	0.7	3.5	90	10.5	17	0 - 60	45	--
EBA.10P.1-MV-I	1	3.5	90	23	34	0 - 60	44.5	--
EBA.10P.2-MV-I	1	3.5	90	23	34	0 - 60	46.5	--
EBA.12P.1-MV-I	1.2	3.5	90	27	47	0 - 60	44.5	--
EBA.12P.2-MV-I	1.2	3.5	90	27	47	0 - 60	45.5	--
EBA.15P.1-MV-I	1.5	3.5	90	37	74	0 - 60	92	--

Dimensions

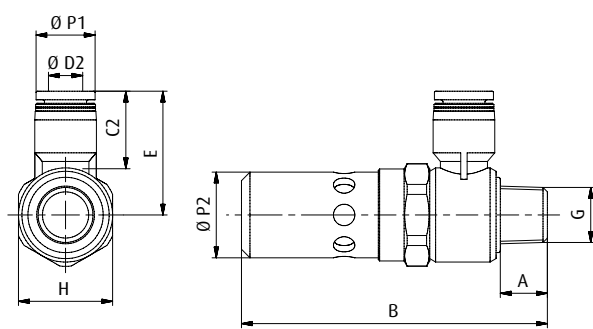

EBA.05H.1-MV - EBA15P.1-MV

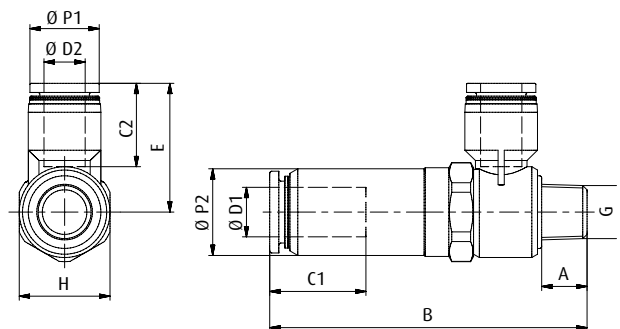

EBA.05H.1-MV-I - EBA15P.1-MV-I



Item no.	G	Ø D1 [mm]	Ø D2 [mm]	A [mm]	B [mm]	C2 [mm]	C1 [mm]	E [mm]	H [mm]	Ø P1 [mm]	Ø P2 [mm]
EBA.05H.1-MV	M5	--	4	4	35	15	--	21.5	8	10	9.5
EBA.05H.2-MV	R1/8	--	6	8	48	16.5	--	25	17	12.5	16
EBA.07H.1-MV	R1/8	--	6	8	48	16.5	--	25	17	12.5	16
EBA.10H.1-MV	R1/8	--	6	8	48	16.5	--	25	17	12.5	16
EBA.10H.2-MV	R1/8	--	8	8	48	17.5	--	28	17	15	16
EBA.12H.1-MV	R1/8	--	6	8	48	16.5	--	25	17	12.5	16
EBA.12H.2-MV	R1/8	--	8	8	48	17.5	--	28	17	15	16
EBA.15H.1-MV	R1/4	--	8	11	72	17.5	--	28	22	14.5	20
EBA.05L.1-MV	M5	--	4	4	35	15	--	21.5	8	10	9.5
EBA.05L.2-MV	R1/8	--	6	8	48	16.5	--	25	17	12.5	16
EBA.07L.1-MV	R1/8	--	6	8	48	16.5	--	25	17	12.5	16
EBA.07L.2-MV	R1/8	--	8	8	48	17.5	--	28	17	15	16
EBA.10L.1-MV	R1/8	--	--	8	48	--	--	25	17	12.5	16
EBA.10L.2-MV	R1/8	--	8	8	48	17.5	--	28	17	15	16
EBA.15L.1-MV	R1/4	--	8	11	72	17.5	--	28	22	14.5	20
EBA.07P.1-MV	R1/8	--	6	8	48	16.5	--	25	17	12.5	16
EBA.10P.1-MV	R1/8	--	6	8	48	16.5	--	25	17	12.5	16
EBA.10P.2-MV	R1/8	--	8	8	48	17.5	--	28	17	15	16
EBA.12P.1-MV	R1/8	--	6	8	48	16.5	--	25	17	12.5	16
EBA.12P.2-MV	R1/8	--	8	8	48	17.5	--	28	17	15	16
EBA.15P.1-MV	R1/4	--	8	11	72	17.5	--	28	22	14.5	20
EBA.05H.1-MV-I	M5	6	4	4	35	15	12.5	21.5	8	9.5	10
EBA.05H.2-MV-I	R1/8	8	6	8	58	16.5	17.5	25	17	16	12.5
EBA.07H.1-MV-I	R1/8	8	6	8	58	16.5	17.5	25	17	16	12.5
EBA.10H.1-MV-I	R1/8	8	6	8	58	16.5	17.5	25	17	16	12.5
EBA.10H.2-MV-I	R1/8	8	8	8	58	17.5	17.5	28	17	16	15
EBA.12H.1-MV-I	R1/8	8	6	8	58	16.5	17.5	25	17	16	12.5
EBA.12H.2-MV-I	R1/8	8	8	8	58	17.5	17.5	28.5	17	16	15
EBA.15H.1-MV-I	R1/4	12	8	11	77	17.5	21.5	28.5	22	20	14.5
EBA.05L.1-MV-I	M5	6	4	4	35	15	12.5	21.5	8	9.5	10
EBA.05L.2-MV-I	R1/8	8	6	8	58	16.5	17.5	25	17	16	12.5
EBA.07L.1-MV-I	R1/8	8	6	8	58	16.5	17.5	25	17	16	12.5
EBA.07L.2-MV-I	R1/8	8	8	8	58	17.5	17.5	28	17	16	15
EBA.10L.1-MV-I	R1/8	8	6	8	58	16.5	17.5	25	17	16	12.5
EBA.10L.2-MV-I	R1/8	8	8	8	58	17.5	17.5	28.5	17	16	15
EBA.15L.1-MV-I	R1/4	12	8	11	77	17.5	21.5	28.5	22	20	14.5
EBA.07P.1-MV-I	R1/8	8	6	8	58	16.5	17.5	25	17	16	12.5
EBA.10P.1-MV-I	R1/8	8	6	8	58	16.5	17.5	25	17	16	12.5
EBA.10P.2-MV-I	R1/8	8	8	8	58	17.5	17.5	28	17	16	15
EBA.12P.1-MV-I	R1/8	8	6	8	58	16.5	17.5	25	17	16	12.5
EBA.12P.2-MV-I	R1/8	8	8	8	58	17.5	17.5	28.5	17	16	15
EBA.15P.1-MV-I	R1/4	12	8	11	77	17.5	21.5	28.5	22	20	14.5

Continued on the next page →



Vacuum generation | Base ejectors

Base ejectors EBA for solenoid valves

Suction power [NI/min] at vacuum level

Item no.	0 %	10 %	20 %	30 %	40 %	50 %	60 %	70 %	80 %	90 %
EBA.05H.1-MV	7	6.2	5.4	4.6	3.8	3	2.2	1.5	0.7	--
EBA.05H.2-MV	7	6.2	5.4	4.6	3.8	3	2.2	1.5	0.7	--
EBA.07H.1-MV	13	11.6	10.1	8.8	7.5	5.9	4.2	3	1.6	0.4
EBA.10H.1-MV	28	25	22	18.9	15.9	12.9	9.9	6.9	3.9	0.9
EBA.10H.2-MV	28	25	22	18.9	15.9	12.9	9.9	6.9	3.9	0.9
EBA.12H.1-MV	38	33.9	29.8	25.7	21.6	17.5	13.4	9.3	5.3	1.2
EBA.12H.2-MV	38	33.9	29.8	25.7	21.6	17.5	13.4	9.3	5.3	1.2
EBA.15H.1-MV	63	56.2	49.4	42.6	35.9	29.1	22.3	15.6	8.8	2
EBA.05L.1-MV	12	10.8	9	7.5	5.5	4	2.5	0.8	--	--
EBA.05L.2-MV	12	10.8	9	7.5	5.5	4	2.5	0.8	--	--
EBA.07L.1-MV	26	22	18.2	14	10	6.3	2.4	--	--	--
EBA.07L.2-MV	26	22	18.2	14	10	6.3	2.4	--	--	--
EBA.10L.1-MV	42	35.6	29.3	22.9	16.5	10.2	3.8	--	--	--
EBA.10L.2-MV	42	35.6	29.3	22.9	16.5	10.2	3.8	--	--	--
EBA.15L.1-MV	95	80.6	66.2	51.8	37.4	23	8.6	--	--	--
EBA.07P.1-MV	10.5	9.3	8.1	7	5.8	4.6	3.5	2.2	1.1	--
EBA.10P.1-MV	21	18.7	16.4	14	11.8	9.5	7.1	4.8	2.5	0.2
EBA.10P.2-MV	21	18.7	16.4	14	11.8	9.5	7.1	4.8	2.5	0.2
EBA.12P.1-MV	27	24	21	18.1	15.1	12	9.2	6.2	3.3	0.3
EBA.12P.2-MV	27	24	21	18.1	15.1	12	9.2	6.2	3.3	0.3
EBA.15P.1-MV	37	32.9	28.8	24.8	20.7	16.6	12.6	8.5	4.5	0.4
EBA.05H.1-MV-I	7	6.2	5.4	4.6	3.8	3	2.2	1.5	0.7	--
EBA.05H.2-MV-I	7	6.2	5.4	4.6	3.8	3	2.2	1.5	0.7	--
EBA.07H.1-MV-I	13	11.6	10.1	8.8	7.5	5.9	4.2	3	1.6	0.4
EBA.10H.1-MV-I	28	25	22	18.9	15.9	12.9	9.9	6.9	3.9	0.9
EBA.10H.2-MV-I	28	25	22	18.9	15.9	12.9	9.9	6.9	3.9	0.9
EBA.12H.1-MV-I	38	33.9	29.8	25.7	21.6	17.5	13.4	9.3	5.3	1.2
EBA.12H.2-MV-I	38	33.9	29.8	25.7	21.6	17.5	13.4	9.3	5.3	1.2
EBA.15H.1-MV-I	63	56.2	49.4	42.6	35.9	29.1	22.3	15.6	8.8	2
EBA.05L.1-MV-I	12	10.8	9	7.5	5.5	4	2.5	0.8	--	--
EBA.05L.2-MV-I	12	10.8	9	7.5	5.5	4	2.5	0.8	--	--
EBA.07L.1-MV-I	26	22	18.2	14	10	6.3	2.4	--	--	--
EBA.07L.2-MV-I	26	22	18.2	14	10	6.3	2.4	--	--	--
EBA.10L.1-MV-I	42	35.6	29.3	22.9	16.5	10.2	3.8	--	--	--
EBA.10L.2-MV-I	42	35.6	29.3	22.9	16.5	10.2	3.8	--	--	--
EBA.15L.1-MV-I	95	80.6	66.2	51.8	37.4	23	8.6	--	--	--
EBA.07P.1-MV-I	10.5	9.3	8.1	7	5.8	4.6	3.5	2.2	1.1	--
EBA.10P.1-MV-I	21	18.7	16.4	14	11.8	9.5	7.1	4.8	2.5	0.2
EBA.10P.2-MV-I	21	18.7	16.4	14	11.8	9.5	7.1	4.8	2.5	0.2
EBA.12P.1-MV-I	27	24	21	18.1	15.1	12	9.2	6.2	3.3	0.3
EBA.12P.2-MV-I	27	24	21	18.1	15.1	12	9.2	6.2	3.3	0.3
EBA.15P.1-MV-I	37	32.9	28.8	24.8	20.7	16.6	12.6	8.5	4.5	0.4

Diagrams see pages 542 - 543



Base ejectors EBM - miniature size

Compressed air connection via quick fittings, vacuum connection via M-threads, exchangeable silencer element

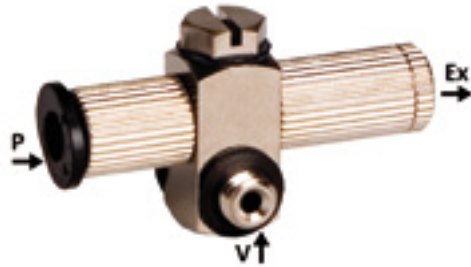
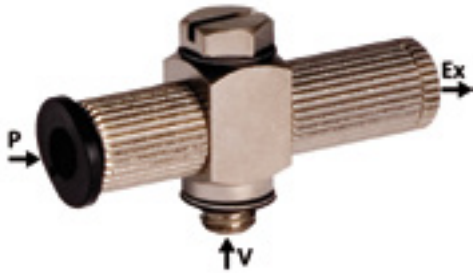

Series with fixed tubing connection

☐ = Vacuum connection ☐ = Compressed air connection ☐ = Exhaust outlet

Product Description

- > High suction power for fast evacuation and short gripping time
- > Easy installation directly on the vacuum cup
- > Small dimensions for installation where space is limited
- > Robust design with nickel-plated brass body
- > Miniature silencer that can be dismantled for fast servicing and short downtimes

Technical data

Item no.	Nozzle diameter [mm]	Optimal feed pressure [bar]	Final vacuum [%]	Suction power [NI/min]	Air consumption at 5 bar [NI/min]	Operating temperature [°C]	Weight [g]	Suitable spare silencer element
EBM.05H.5	0.5	5	90	7	11.5	0 - 60	14.5	EBA.05-S
EBM.05H.6	0.5	5	90	7	11.5	0 - 60	14.5	EBA.05-S
EBM.05H.5-W	0.5	5	90	7	11.5	0 - 60	17	EBA.05-S
EBM.05H.6-W	0.5	5	90	7	11.5	0 - 60	17.5	EBA.05-S

Dimensions

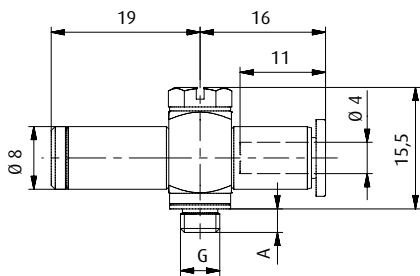

EBM.05H.5 | EBM.05H.6

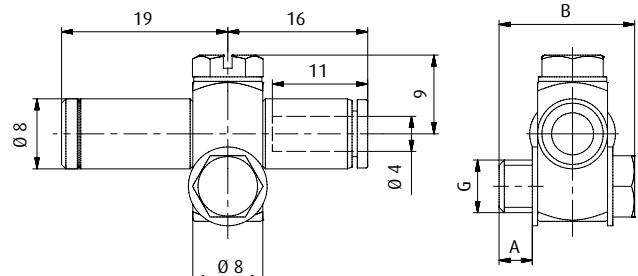

EBM.05H.5-W | EBM.05H.6-W

Item no.	G	A [mm]	B [mm]
EBM.05H.5	M5	3.5	--
EBM.05H.6	M6	4	--
EBM.05H.5-W	M5	4	14.5
EBM.05H.6-W	M6	6	15.5

Suction power [NI/min] at vacuum level

Item no.	0 %	10 %	20 %	30 %	40 %	50 %	60 %	70 %	80 %
EBM.05H.5	7	6.2	5.4	4.6	3.8	3.1	2.3	1.5	0.7
EBM.05H.6	7	6.2	5.4	4.6	3.8	3.1	2.3	1.5	0.7
EBM.05H.5-W	7	6.2	5.4	4.6	3.8	3.1	2.3	1.5	0.7
EBM.05H.6-W	7	6.2	5.4	4.6	3.8	3.1	2.3	1.5	0.7

Diagrams see pages 542 - 543

Diagrams

> Suction power and air consumption against feed pressure

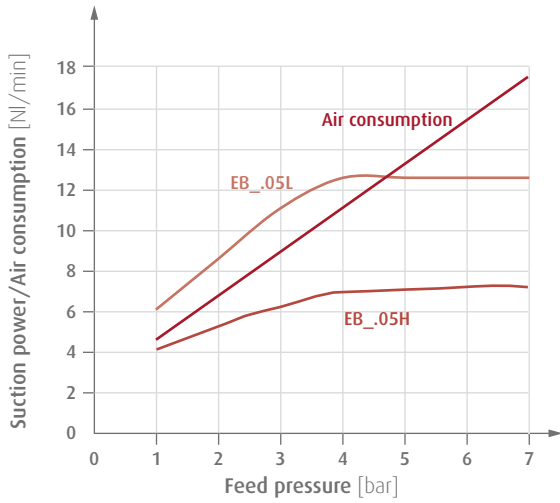

> Vacuum level against feed pressure

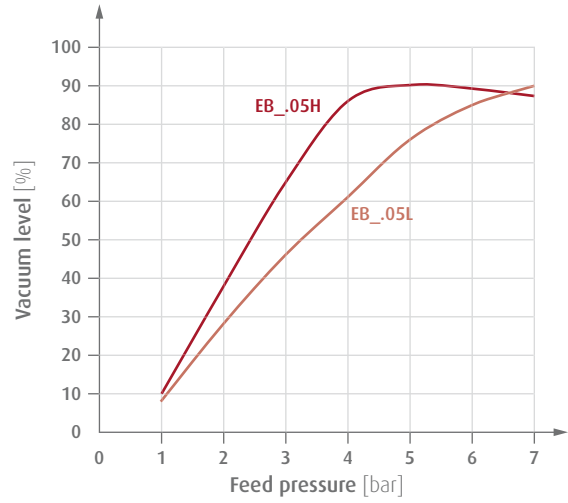

> Suction power and air consumption against feed pressure

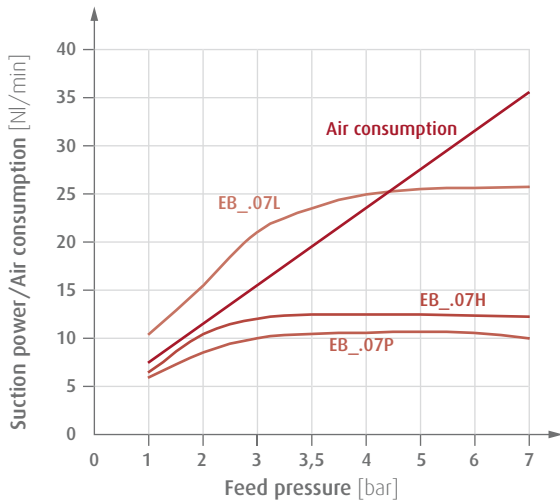

> Vacuum level against feed pressure

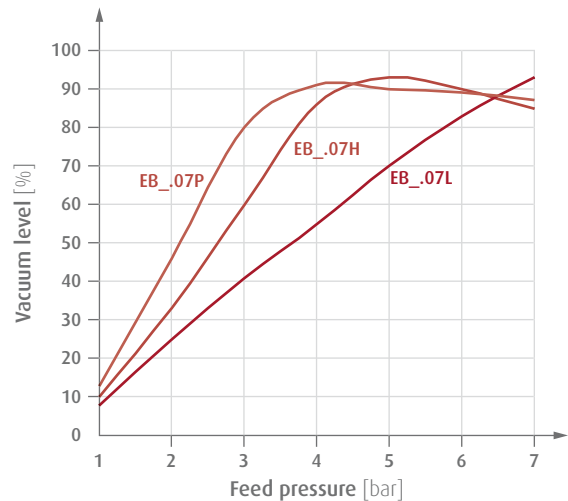

> Suction power and air consumption against feed pressure

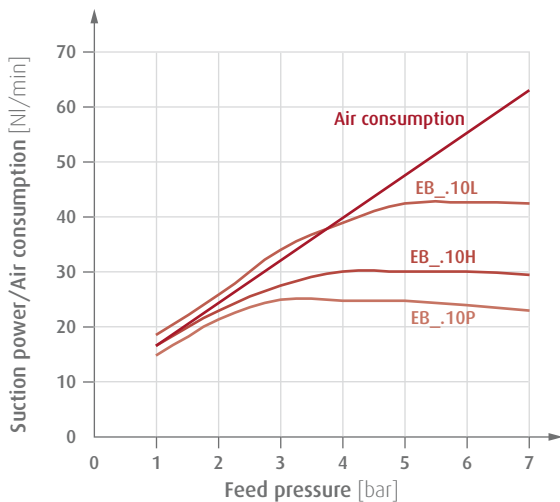

> Vacuum level against feed pressure

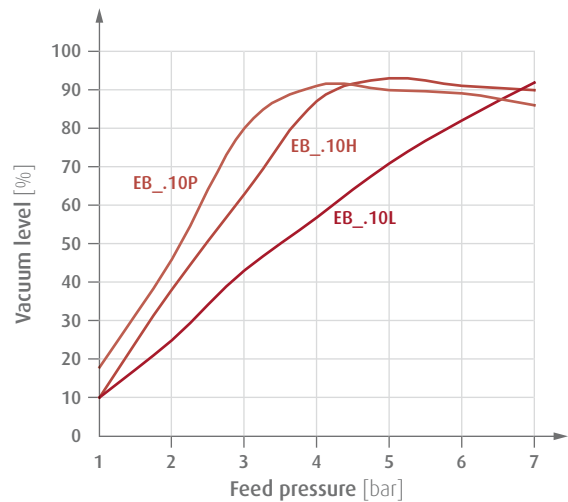



Diagrams

> Suction power and air consumption against feed pressure

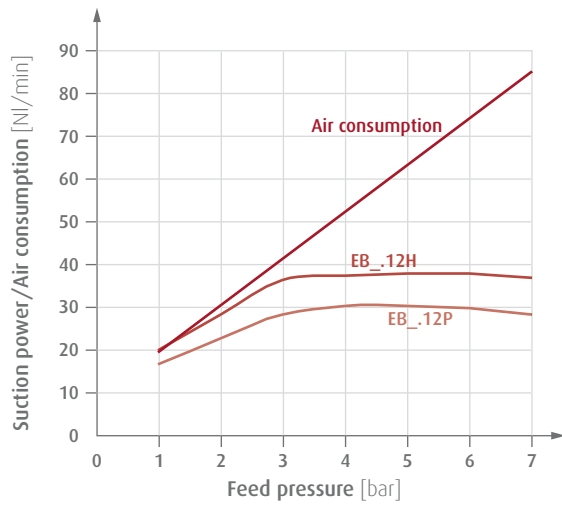

> Vacuum level against feed pressure

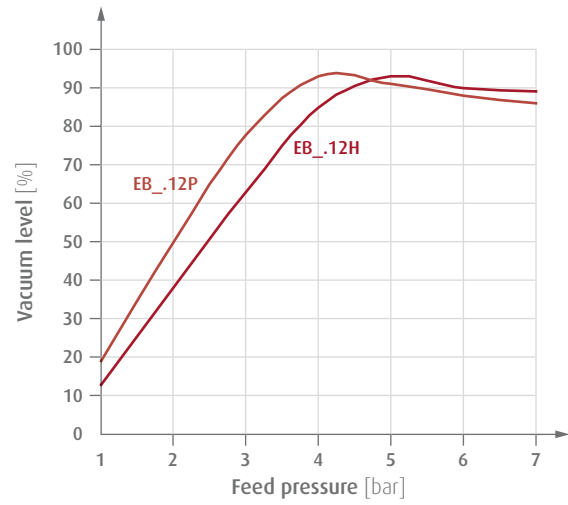

> Suction power and air consumption against feed pressure

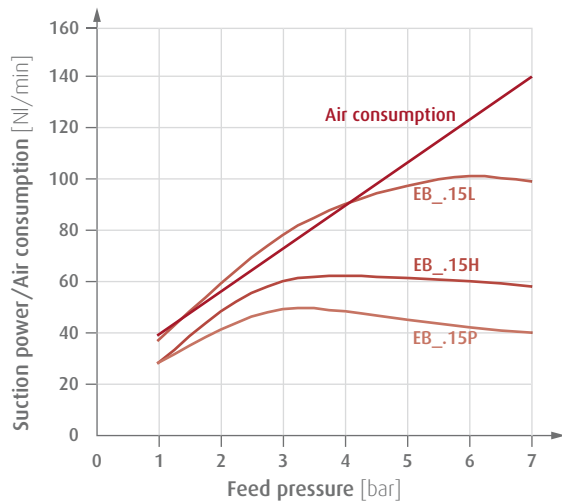

> Vacuum level against feed pressure

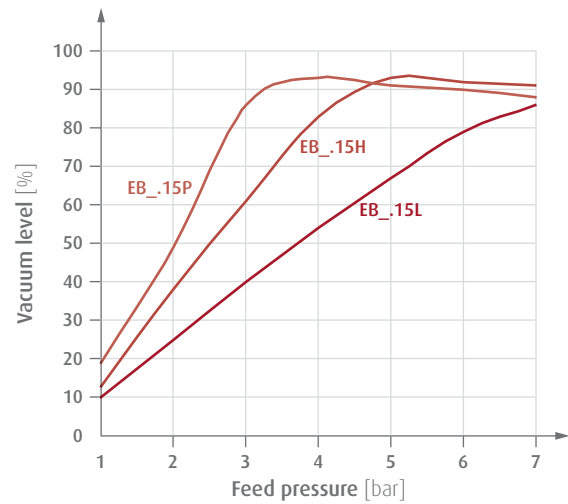

> Suction power and air consumption against feed pressure

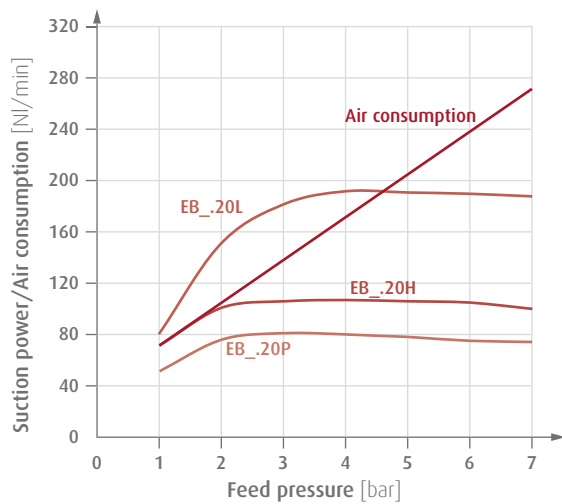

> Vacuum level against feed pressure

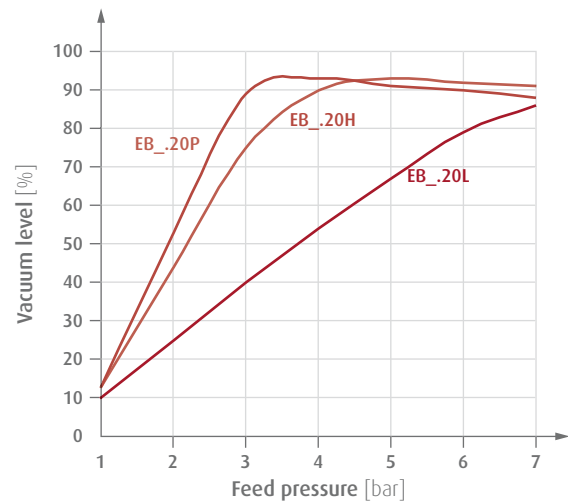



Heavy-duty ejectors

Vacuum generation under harsh conditions of use



Product Description

- > Robust and compact aluminium housing
- > Compensation of compressed air fluctuations between 3 and 6 bar
- > Additional inlet for blow-off for fast product release or vacuum switch connection for process monitoring (65.111, 65.130)
- > Rectangular design enables block assembly in centralised or decentralised vacuum systems

Technical data

Item no.	Optimal feed pressure [bar]	Max. feed pressure [bar]	Final vacuum [%]	Suction power [Nl/min]	Air consumption to 4 bar [Nl/min]	Evacuation time 0 to 70 % [s/l]	Weight [g]	Suitable accessories
65.102A	4	6	85	30	50	3.5	48	Silencer 72.001 (p.578) Silencer 72.029 (p.577)
65.111	4	6	85	33	60	3	120	Silencer 72.002 (p.578) Silencer 72.030 (p.577)
65.120	4	6	85	85	130	1.5	125	Silencer 72.031 (p.577)
65.130	4	6	85	130	240	0.7	225	--

Dimensions

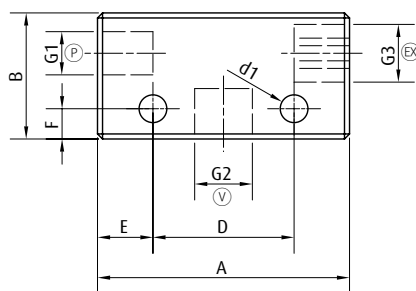
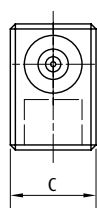

65.102A

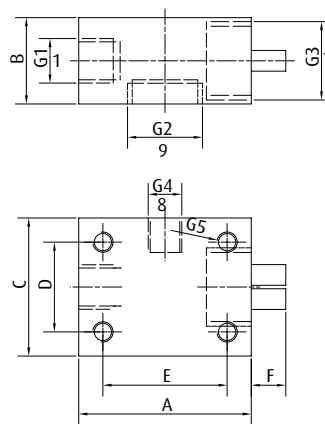

65.111 | 65.120 | 65.130

Ⓟ = Compressed air connection Ⓥ = Vacuum connection Ⓧ = Exhaust Ⓩ = Blow-off (65.111 and 65.130)

Item no.	G1	G2	G3	G4	G5	A [mm]	B [mm]	C [mm]	D [mm]	d1 [mm]	E [mm]	F [mm]
65.102A	G1/8	G1/4	G1/4	--	--	50	25	17	28	5.5	11	6
65.111	G1/4	G1/2	G3/8	G1/8	6.5	50	25	40	25	--	34	8
65.120	G1/4	G1/2	G1/2	G1/8	M6	50	25	40	25	--	34	10
65.130	G1/4	G1/2	G1	G1/8	M6	60	40	40	25	--	34	--



Diagrams

> Suction power against feed pressure

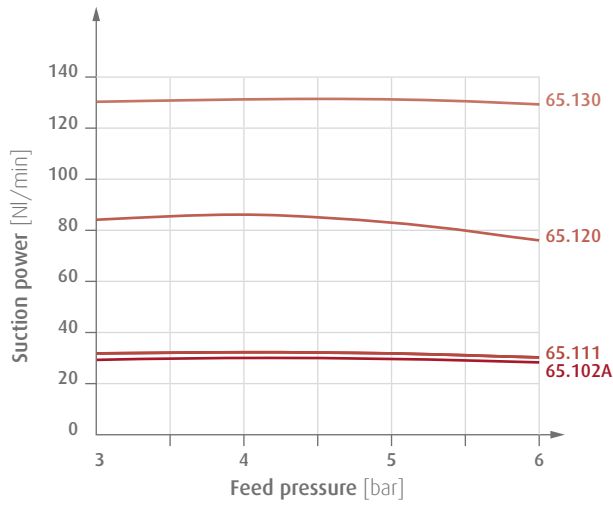

> Air consumption against feed pressure

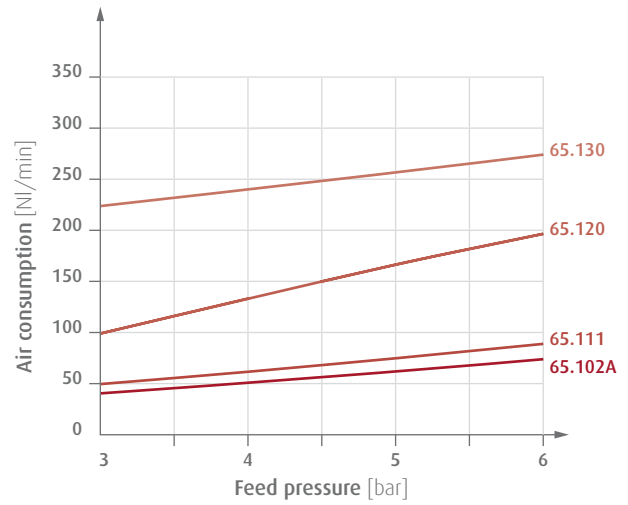

> Vacuum level against feed pressure

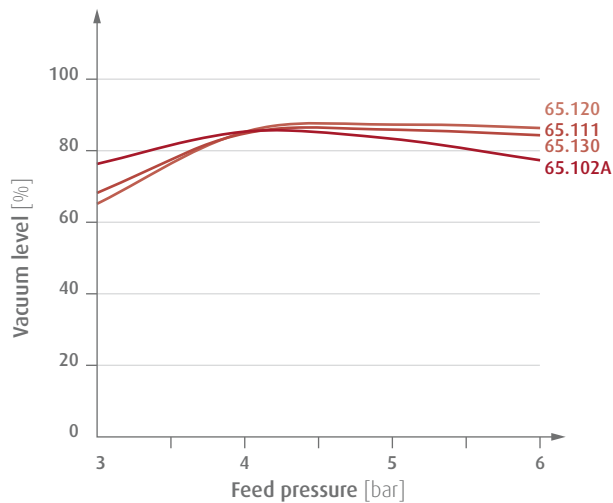

Suction power [NI/min] at vacuum level

Item no.	10 %	20 %	30 %	40 %	50 %	60 %	70 %	80 %
65.102A	25	23	19	15	13	8	4	1
65.111	25	23	20	17	13	8	4	1
65.120	76	66	55	41	34	22	12	3
65.130	182	160	135	69	52	33	17	6



FIPA Multi-chamber ejectors

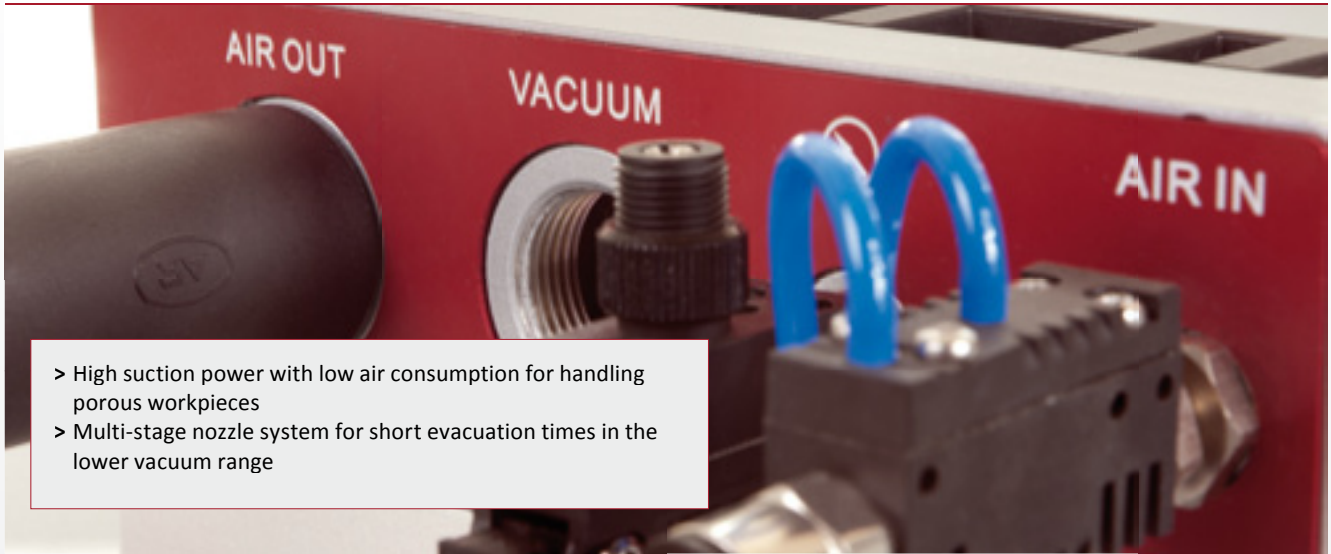

- > High suction power with low air consumption for handling porous workpieces
- > Multi-stage nozzle system for short evacuation times in the lower vacuum range



Multi-chamber ejectors 65.310 - 65.330

- > Robust aluminium construction
- > Very compact design for space-saving installation in handling systems
- > Low weight allows for high handling dynamics

> See page 548



Multi-chamber ejectors 65.410

- > Robust aluminium construction
- > Particularly fast product release due to additional compressed air inlet for blow-off

> See page 548



Multi-chamber ejectors 65.340 - 65.390

- > Robust aluminium construction
- > Compensation of fluctuations in compressed air supply
- > Compressed air inlet for blow-off enables fast release of the workpiece (65.410)
- > Optional air-saving function when handling dense products

> See page 550



FIPA Multi-chamber ejectors

Examples of use

- > Handling porous materials (cardboard, wood fiber boards, insulation materials, etc.)
- > Handling dense workpieces at moderate cycle times (single-stage ejectors such as basic or compact ejectors are generally preferable for short cycle times in the handling of heavy products, as these more quickly achieve high vacuum levels)

Multi-chamber ejectors with air-saving function (65.340-LSE - 65.390-LSE)

- > Handling of products with different air permeabilities (activation of the air-saving function for heavy products)
- > Switch-off of vacuum generation while assuming a “waiting position” in the event of a delay in downstream processes
- > Saving compressed air when using multi-chamber ejectors for the supply of vacuum tanks

Functional principle

Prior to discharge into the atmosphere, the compressed air flows through a series of several connected nozzle chambers. In this way the kinetic energy of the supplied compressed air generates a partial vacuum in each of the chambers. These ejectors set themselves apart from single-stage ejectors such as basic or compact ejectors thanks to their lower consumption of compressed air despite the same suction power.

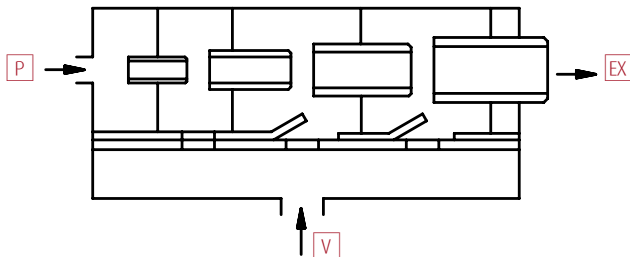



Multi-chamber ejectors



Product Description

- > Handling of air-permeable products, or for high leakages
- > High suction power for short evacuation times and fast vacuum build-up
- > Low space requirements due to small construction size (65.310 - 65.330)
- > Particularly fast product release due to additional compressed air inlet for blow-off (65.410)
- > Noise-optimised operation due to open silencer
- > Industry examples: packaging and printing

Technical data

Item no.	Optimal feed pressure [bar]	Max. feed pressure [bar]	Final vacuum [%]	Suction power [NI/min]	Air consumption at 6 bar [NI/min]	Evacuation time 0 to 70 % [s/l]	Weight [g]
65.310	6	7	85	120	56	1.95	111
65.320	6	7	85	180	108	1.07	111
65.330	6	7	85	250	144	0.5	169
65.410	6	7	85	320	95	1.15	1,006

Dimensions

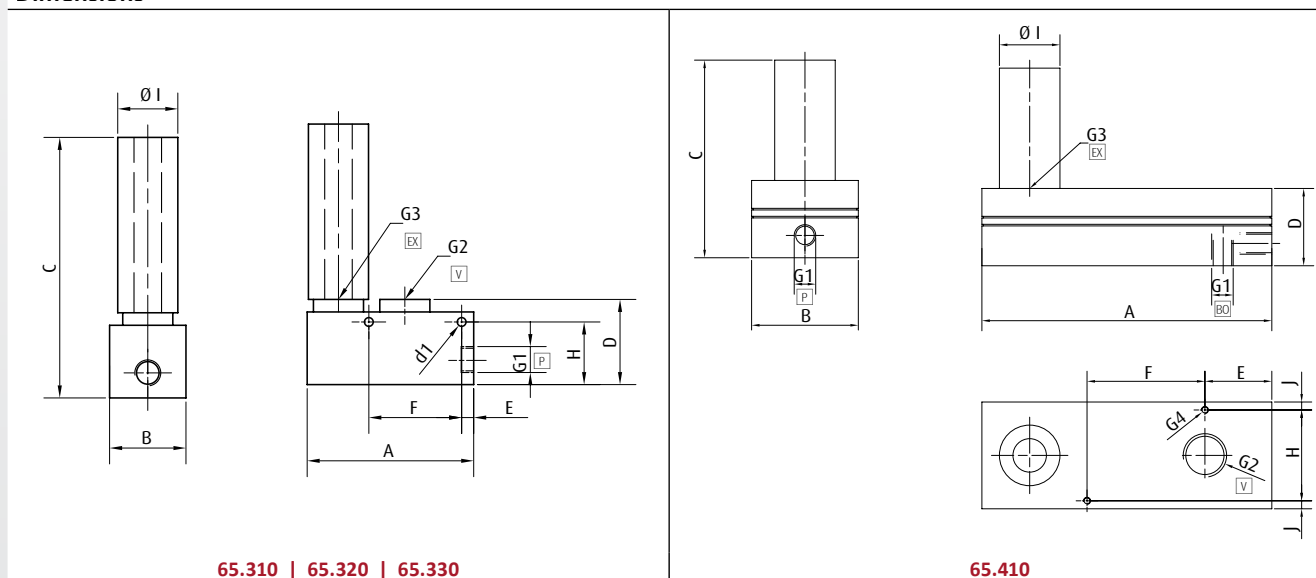

65.310 | 65.320 | 65.330

65.410

[P] = Compressed air connection [V] = Vacuum connection [EX] = Exhaust [BO] = Compressed air connection for blow-off

Item no.	G1	G2	G3	G4	A [mm]	B [mm]	C [mm]	D [mm]	d1 [mm]	E [mm]	F [mm]	H [mm]	Ø I [mm]	J [mm]
65.310	G1/8	G3/8	G3/8	--	67	31	104	34	3.7	9.6	32.5	24	24	--
65.320	G1/8	G1/8	G3/8	--	67	31	104	34	3.7	9.6	32.5	24	24	--
65.330	G1/8	G1/2	G3/8	--	67	45	114	44	3.7	10.5	46.5	13.3	24	--
65.410	G1/4	G1/2	G1/2	M4	182	67	124.5	49	--	41.5	74	57	38	5



Diagrams

> Air consumption against feed pressure

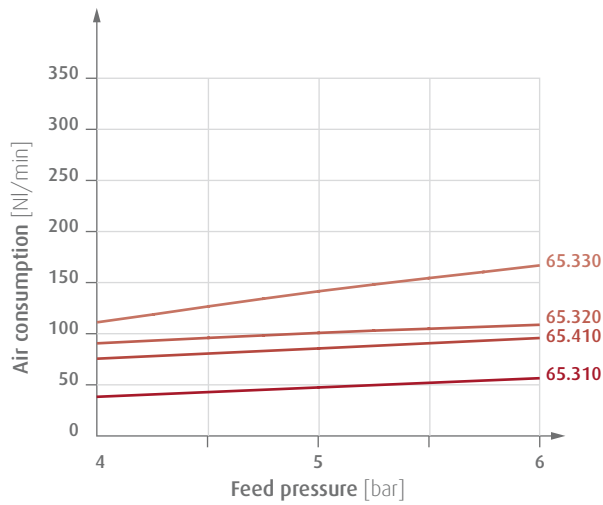

> Suction power against feed pressure

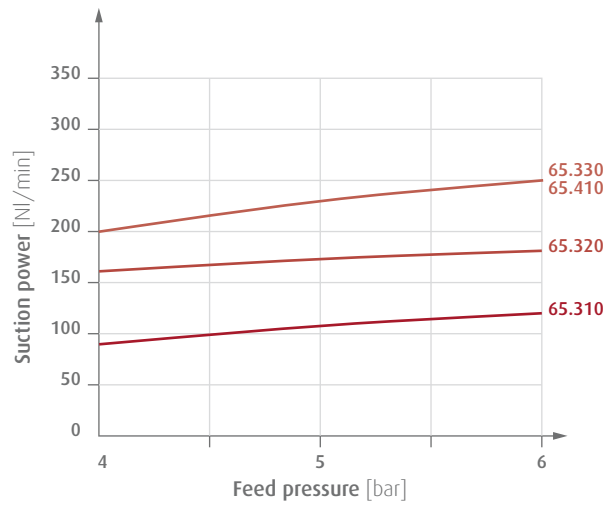

> Vacuum level against feed pressure

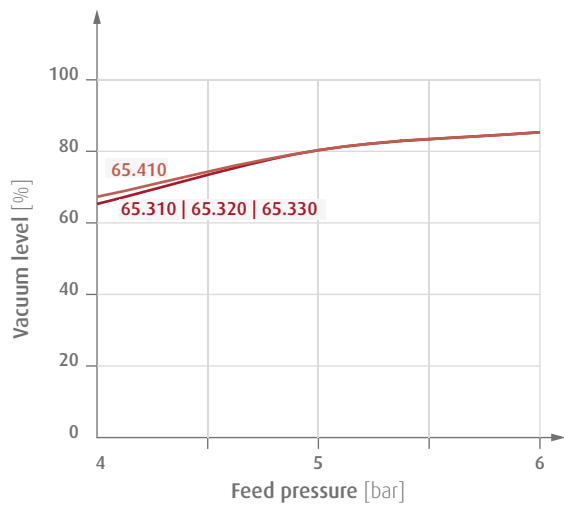

Suction power [NI/min] at vacuum level

Item no.	10 %	20 %	30 %	40 %	50 %	60 %	70 %	80 %
65.310	89	62	38	22	18	10	5	--
65.320	130	81	52	30	22	14	8	--
65.330	178	116	91	63	44	15	6	--
65.410	175	118	58	42	33	23	16	10



Multi-chamber ejectors

High suction power for fast vacuum build up with porous workpieces

NEW



Application example: Multi-chamber ejector with vacuum gauge 91.001 (mounting on front or rear side)



Application example: Multi-chamber ejector 65.340-LSE with air saving function

Product Description

- > High vacuum level at low feed pressures, and thus particularly efficient use of compressed air as well as suitability for fluctuating air pressure levels
- > Handling of porous products, or for high leakages
- > High suction power for short evacuation times in the lower vacuum range
- > Noise-optimised operation due to open silencer
- > Industry examples: packaging and printing

Air saving function (Index LSE)

- > Saving compressed air during handling of dense workpieces
- > Examples of use:
Automatic switching off of vacuum generation during pick-and-place applications of dense workpieces if e.g. downstream processes are delayed. Saving compressed air when using the multi-chamber ejectors for feeding vacuum tanks.

Notes

Construction / operation (Index -LSE):

- > Combination of pneumatic control valve with spring return and normally closed (NC) pneumatic vacuum switch
- > Setting target vacuum values by means of setting screw
- > Compressed air is conveyed through the valve to the compressed-air inlet of the injector; there is a partial airflow at input 1 of the vacuum switch
- > When set target vacuum is reached, vacuum switch opens, compressed air from input 1 is conducted to the control valve via output 2 and closes it - the vacuum generation is stopped
- > If the vacuum level has reached the hysteresis value (see table), the vacuum switch closes again and the spring opens the control valve - vacuum generation is activated again
- > Please note: The air saving function does not work with porous products, or in the case of high leakage

Ordering notes

- > Seals optionally available in NBR as standard
- > Optionally available in EPDM or Viton upon request
- > Included in scope of delivery: two mounting brackets and G1/4"-AG - Ø 10 mm quick fitting for compressed air connection

Technical data

Item no.	65.340	65.350	65.360	65.370	65.380	65.390
Optimal feed pressure [bar]	3.4	3.4	3.4	3.4	3.4	3.4
Max. feed pressure [bar]	7	7	7	7	7	7
Final vacuum at 3.4 bar [%]	92	92	92	92	92	92
Final vacuum at 6 bar [%]	89	89	89	89	89	89
Suction power at 3.4 bar [NI/min]	360	600	760	850	1,150	1,200
Suction power at 6 bar [NI/min]	420	700	950	1,010	1,400	1,500
Air consumption at 3.4 bar [NI/min]	116	230	365	445	545	655
Air consumption at 6 bar [NI/min]	185	370	610	720	780	810
Evacuation time 1 liter from 0 to 70 % at 3.4 bar [s]	0.95	0.5	0.46	0.27	0.2	0.23



Technical data

Item no.	65.340	65.350	65.360	65.370	65.380	65.390
Evacuation time 0 to 70 % at 6 bar [s]	0.62	0.35	0.31	0.19	0.19	0.2
Vacuum switch hysteresis at LSE [mbar]	120	120	120	120	120	120
Noise level with silencer [dB]	60 - 65	60 - 65	60 - 65	60 - 65	60 - 65	60 - 65
Usage temperature [°C]	-20 - 80	-20 - 80	-20 - 80	-20 - 80	-20 - 80	-20 - 80
Weight incl. silencer [g]	690	690	880	880	1,160	1,160
Suitable accessories	Vacuum gauge 91.001 (p.696) Vacuum switch 20.021 (p.691) Double nipple 270.138 (p.751) Double nipple 270.148 (p.751)					

When ordering please specify

Air saving function

Item no.	Design
65.340	without air saving function
65.340 -LSE	with air saving function

Already built in for 65.340-LSE to 65.390-LSE.

If the LSE is integrated in already delivered structurally identical ejectors without an air saving function, a non-return valve, item no. 32.662, is necessary at the compressed air input. For conversion of existing ejectors please consult the FIPA technical sales department.

For 65-380-LSE and 65.390-LSE:

It is recommended particular to consult FIPA technical sales department as to whether an air saving function is useful in the application.

Wiring diagram air saving function LSE

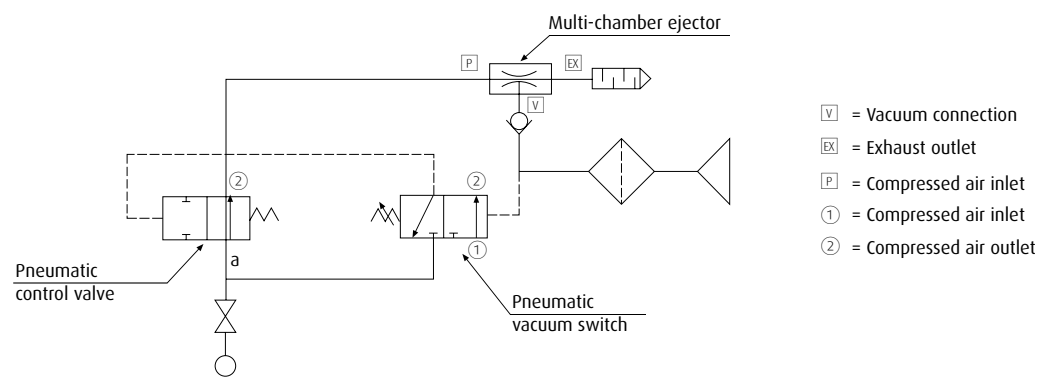

Continued on the next page →



Suction power [NI/min] at vacuum level (feed pressure 3.4 bar)

Item no.	10 %	20 %	30 %	40 %	50 %	60 %	70 %	80 %	90 %
65.340	180	115	80	43	30	22.5	15.5	7.5	1.2
65.350	320	250	135	75	60	46	30	13	1.5
65.360	445	340	175	110	85	70	43	20	1.8
65.370	550	430	280	145	115	85	60	28	2.2
65.380	760	530	350	180	148	115	78	34.5	3.5
65.390	830	550	360	215	170	130	90	36	5

Suction power [NI/min] at vacuum level (feed pressure 6 bar)

Item no.	10 %	20 %	30 %	40 %	50 %	60 %	70 %	80 %	90 %
65.340	240	125	100	82	65	38	12.5	3.5	--
65.350	510	290	195	160	115	70	22	8	--
65.360	710	380	285	230	170	100	32	11	--
65.370	800	460	385	310	215	125	42	15.5	--
65.380	1120	560	490	355	260	150	50	25	--
65.390	1110	630	560	385	315	210	65	26	--

Evacuation time [s/l] at vacuum level (operating pressure 3.4 bar)

Item no.	10 %	20 %	30 %	40 %	50 %	60 %	70 %	80 %	90 %
65.340	0.022	0.06	0.11	0.21	0.4	0.65	0.95	1.6	4
65.350	0.014	0.031	0.06	0.1	0.2	0.34	0.5	0.8	2.5
65.360	0.012	0.029	0.058	0.095	0.18	0.31	0.46	0.89	1.5
65.370	0.01	0.025	0.043	0.075	0.11	0.19	0.27	0.45	1.2
65.380	0.006	0.015	0.029	0.052	0.085	0.145	0.202	0.33	1
65.390	0.005	0.013	0.027	0.045	0.07	0.105	0.23	0.46	0.9

Evacuation time [s/l] at vacuum level (operating pressure 6 bar)

Item no.	10 %	20 %	30 %	40 %	50 %	60 %	70 %	80 %	90 %
65.340	0.018	0.05	0.08	0.18	0.25	0.4	0.62	1.55	--
65.350	0.01	0.022	0.048	0.08	0.11	0.2	0.35	0.78	--
65.360	0.009	0.019	0.045	0.075	0.13	0.18	0.31	0.7	--
65.370	0.007	0.018	0.038	0.055	0.08	0.12	0.19	0.47	--
65.380	0.005	0.013	0.026	0.045	0.062	0.115	0.194	0.56	--
65.390	0.003	0.009	0.014	0.030	0.060	0.095	0.2	0.8	--



Recommended inner diameter [mm] for tubing up to length of 2 meter

Item no.		Air supply	Vacuum	Exhaust
65.340	65.340-LSE	> 4	> 12	> 12
65.350	65.350-LSE	> 6	> 15	> 15
65.360	65.360-LSE	> 8	> 19	> 22
65.370	65.370-LSE	> 8	> 19	> 22
65.380	65.380-LSE	> 10	> 25	> 32
65.390	65.390-LSE	> 10	> 25	> 32

Dimensions

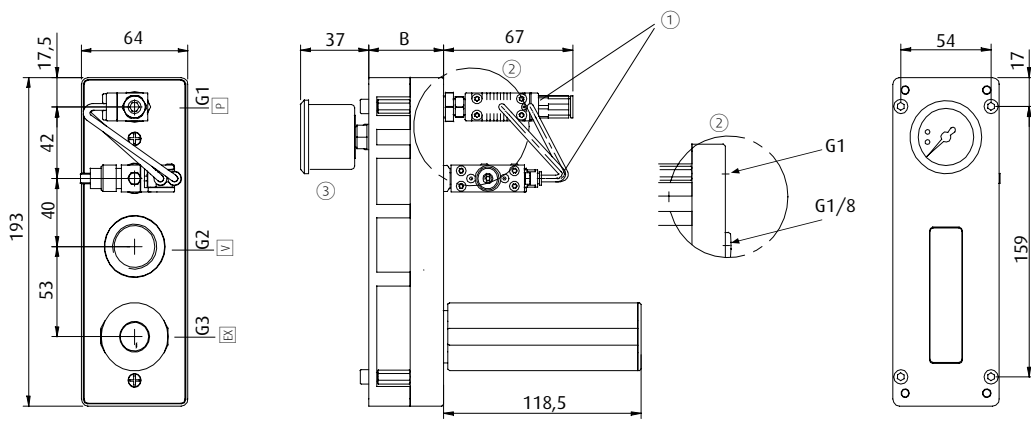

① = Air saving function (optional) ② = Connection vacuum gauge and/or vacuum switch ③ = Vacuum gauge (optional)
 P = Compressed air connection V = Vacuum connection E = Exhaust outlet

Item no.	65.340	65.350	65.360	65.370	65.380	65.390
G2	G3/4	G3/4	G3/4	G3/4	G1	G1
G3	G3/4	G3/4	G3/4	G3/4	G1	G1
A [mm]	163.5	163.5	183.5	183.5	203.5	203.5
B [mm]	45	45	65	65	85	85
G1	G1/4	G1/4	G1/4	G1/4	G1/4	G1/4

Continued on the next page →



Diagrams

> Air consumption against feed pressure

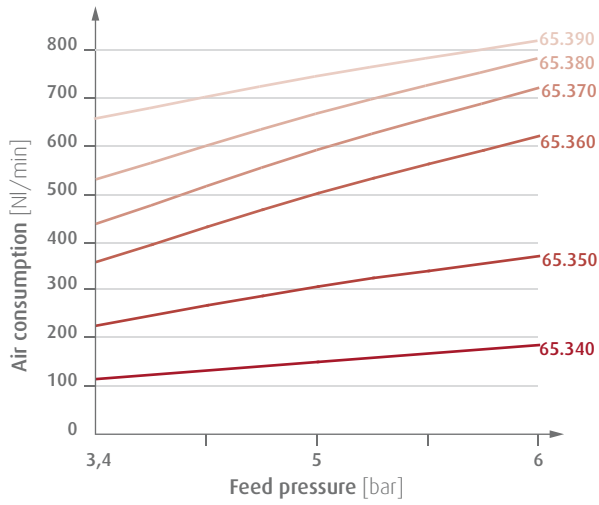

> Suction power against feed pressure

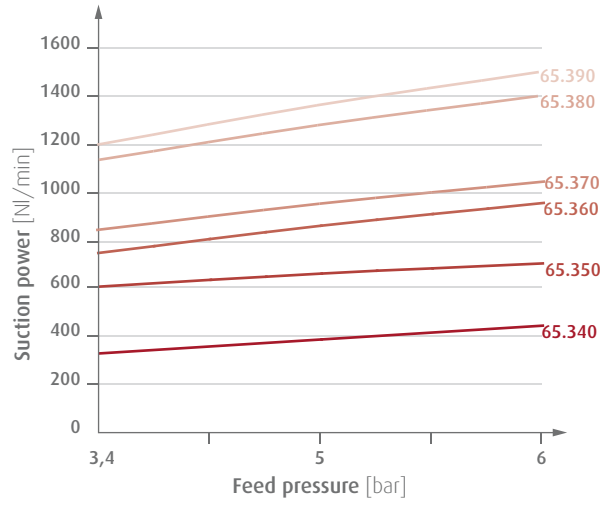

> Vacuum level against feed pressure

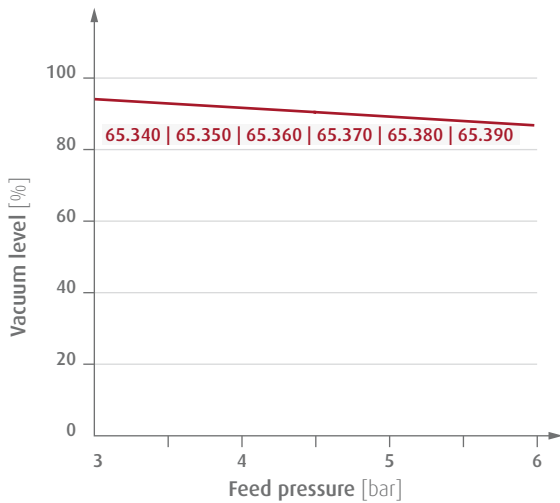



FIPA Compact ejectors



> Highly efficient vacuum supply, regardless of the air permeability of the workpiece



Compact ejectors EMM / EMA

- > Handling of dense and porous workpieces
- > Very compact design for in-line installation directly onto the vacuum cup
- > Integrated vacuum monitoring
- > Integrated pressure-regulating air saving function reduces operating costs by up to 50 %

EMM

- > Pressure-regulating air saving function plus valves for electronic vacuum and blow-off control ensure short cycle times

> See page 556

EMA

- > Pressure-regulating air saving function and electronic air saving function reduce operating costs by up to 97 % for dense workpieces

> See page 559



Compact ejectors EKPP / EKP

- > Handling of dense and porous workpieces
- > Integrated pressure-regulating air saving function reduces operating costs by up to 50 %
- > Process monitoring via optional vacuum switch

EKPP

- > Base version, with pressure-regulating air saving function, no valves
- > Performance data identical to that of EKP

EKP

- > Pressure-regulating air saving function plus electronic vacuum and blow-off control for short cycle times

> See page 563



Vacuum generation | Compact ejectors

Ejectors with air saving function EMM

Ejectors with air saving function EMM

Energy saving function by integrated pressure control



SAVES UP TO 50 % OF ENERGY

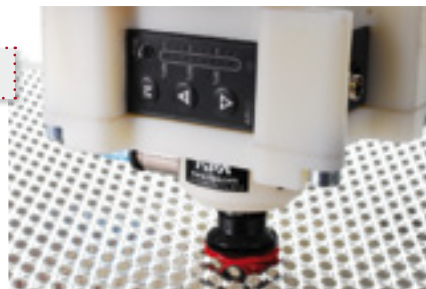

Ejector EMM integrated into gripper housing for Delta robots with Varioflex® bellows vacuum cups and workpiece

V = Vacuum connection
 P = Compressed air connection
 Ex = Exhaust outlet

Product Description

- > Handling of dense and porous workpieces
- > Within the supply pressure of 4 - 8 bar, the ejector works at 3.5 bar with same high performance
- > Energy saving increases along with the difference between supply pressure and operating pressure
- > Electronic vacuum and blow-off control for short cycle times
- > Manual adjustment of the blow-off flow rate using a setscrew
- > Very compact design with integrated open silencer
- > Dust-resistant design, no additional filters required

Ordering notes

- > Two model ranges available
 - EMM.90: for dense workpieces, max. vacuum level 90 %
 - EMM.60: Higher suction power for porous workpieces, max. vacuum level 60 %
- > Optionally available with integrated check valve to maintain vacuum in case of power failure

Technical data

Item no.	EMM.60x10	EMM.60x12	EMM.60x14	EMM.90x10	EMM.90x12	EMM.90x14
Nozzle diameter [mm]	1	1.2	1.4	1	1.2	1.4
Feed pressure [bar]	4 - 8	4 - 8	4 - 8	4 - 8	4 - 8	4 - 8
Internal working pressure [bar]	3.5	3.5	3.5	3.5	3.5	3.5
Final vacuum [%]	60	60	60	90	90	90
Suction power [NI/min]	38	72	92	29	45	70
Air consumption [NI/min]	44	65	90	44	65	90
Protection class	IP65	IP65	IP65	IP65	IP65	IP65
Operating principle	NC	NC	NC	NC	NC	NC
Control voltage	24 VDC (adjusted) ± 10 %	24 VDC (adjusted) ± 10 %	24 VDC (adjusted) ± 10 %	24 VDC (adjusted) ± 10 %	24 VDC (adjusted) ± 10 %	24 VDC (adjusted) ± 10 %
Current consumption for vacuum and blow-off feature [mA]	30 (0.7 W)	30 (0.7 W)	30 (0.7 W)	30 (0.7 W)	30 (0.7 W)	30 (0.7 W)
Operating temperature [°C]	10 - 60	10 - 60	10 - 60	10 - 60	10 - 60	10 - 60
Weight [g]	120	120	120	120	120	120
Suitable connector cable	20.501 (p.717) 20.502 (p.717)	20.501 (p.717) 20.502 (p.717)	20.501 (p.717) 20.502 (p.717)	20.501 (p.717) 20.502 (p.717)	20.501 (p.717) 20.502 (p.717)	20.501 (p.717) 20.502 (p.717)



When ordering please specify

Type + Vacuum level x Nozzle diameter + Composition of module + Vacuum switch = Item number

Example: **EMM.90x12-AVA**

(Compact ejector EMM, vacuum level 90 %, nozzle diameter 1.2 mm, with controlled blow-off-function and with electric vacuum switch with display)

1.: Type	2.: Vacuum level		3.: Nozzle diameter		4.: Composition of module		5.: Vacuum switch		6.: Optional	
EMM.	60	max. 60 % vacuum (porous products)	X	10	∅ 1.0 mm	E	without blow-off-function	VA	digital with display	_CV (with check valve)
		max. 90 % vacuum (non-porous products)		12	∅ 1.2 mm	A	with controlled blow-off-function	VO	without vacuum switch	
		14		∅ 1.4 mm						

Suitable connector cables for vacuum switch:

20.501: M8 thread, female, 4-pin, straight plug, cable length 5 m

20.502: M8 thread, female, 4-pin, 90° elbow plug, cable length 5 m

Display of the energy saving potential by integrated pressure control

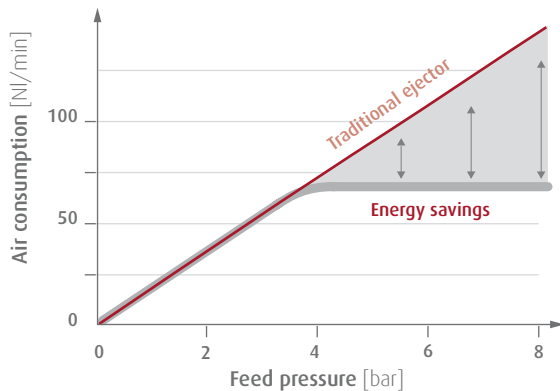

Vacuum switches

Ejectors without vacuum switch

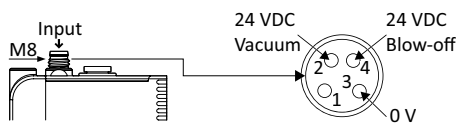

Ejectors with vacuum switch

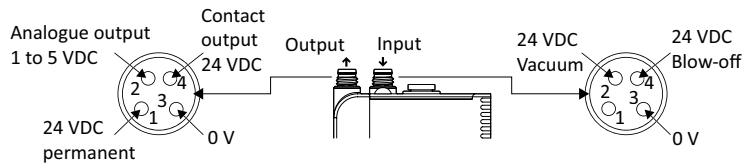

Continued on the next page →



Vacuum generation | Compact ejectors

Ejectors with air saving function EMM

Pneumatic Diagram

Ejector with blow-off-function
EMM__X__EV__

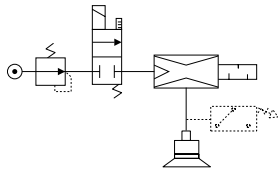

- > Basic product
- > Only one control signal
- > Display of vacuum level
- > Manual control option

Ejector with controlled blow-off-function
EMM__X__AV__

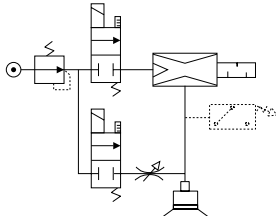

- > Automatic blow-off through external signal, with adjusting screw
- > Two control signals
- > Display of vacuum level and blow-off-function
- > Manual control option

Dimensions and mounting options

> Mounting sideways

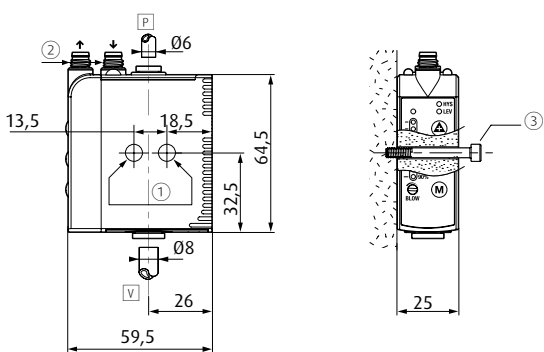

> Mounting in the front

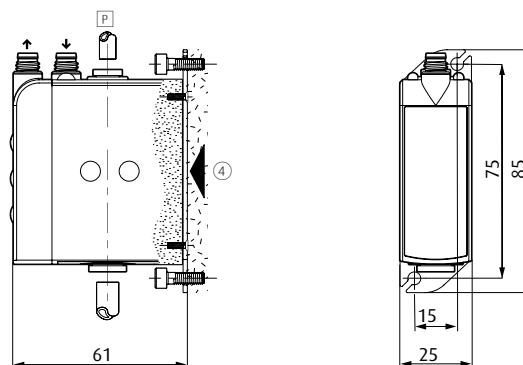

> Block mounting on a DIN rail

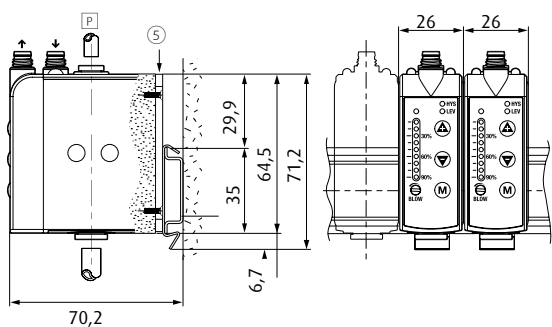

- P = Compressed air connection V = Vacuum connection ① = 2 Bore holes for 4 mm screws ② = M8 plug ③ = 2 Continuous screws
 ④ = Mounting plate with 4 screws (Item no. EMM.FIX-V)
 ⑤ = Mounting plate for DIN rail with 4 screws (Item no. EMM.FIX-D) - on plate per EMM-module

Evacuation time [sec.] for 1 liter at vacuum level

Item no.	30 %	40 %	45 %	50 %	55 %	60 %	65 %	70 %	75 %	80 %
EMM.60x10	0.66	1.04	1.31	1.7	2.35	--	--	--	--	--
EMM.60x12	0.41	1.66	0.83	1.07	1.49	--	--	--	--	--
EMM.60x14	0.27	0.43	0.54	0.7	0.97	--	--	--	--	--
EMM.90x10	--	--	--	--	1.76	2.04	2.38	2.8	3.33	4.09
EMM.90x12	--	--	--	--	1.13	1.31	1.8	2.15	2.15	2.64
EMM.90x14	--	--	--	--	0.73	0.85	0.99	1.16	1.38	1.7



Ejectors with air saving function EMA

Double energy efficient by integrated pressure control and electronic air saving function



SAVES UP TO 97 % OF ENERGY

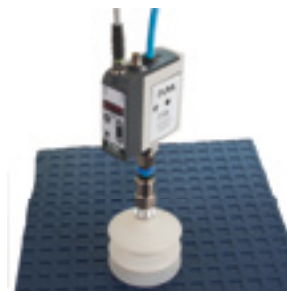

Ejector EMA with bellows vacuum cup and workpiece

Product Description

- > Electronic air saving function reduces operating costs by up to 97 % with dense workpieces
- > Pressure regulation energy-saving function at constant 3.5 bar reduces operating costs by up to 50 % with porous workpieces
 - Energy saving increases along with the difference between supply pressure and operating pressure
- > Electronic vacuum and blow-off control for short cycle times
- > Manual adjustment of the blow-off flow rate using a setscrew
- > Very compact design with integrated open silencer
- > Dust-resistant design, no additional filters required

Notes

- > If the ejector experiences power failure, the workpiece is only held by the vacuum between non-return valve and product surface
- > Vacuum and blow-off are controlled using a single signal

Technical data

Item no.	EMA.90x14
Nozzle diameter [mm]	1.4
Feed pressure [bar]	4 - 8
Internal working pressure [bar]	3.5
Final vacuum [%]	90
Suction power [NI/min]	70
Air consumption [NI/min]	90
Protection class	IP65
Operating principle	NC
Control voltage	24 VDC (adjusted) ± 10 %
Current consumption for vacuum and blow-off feature [mA]	30 (0.7 W)
Operating temperature [°C]	10 - 60
Weight [g]	130
Suitable connector cable	20.502 (p.717) 20.501 (p.717)

Continued on the next page →



Vacuum generation | Compact ejectors

Ejectors with air saving function EMA

Pneumatic diagram

Solenoid valve NC

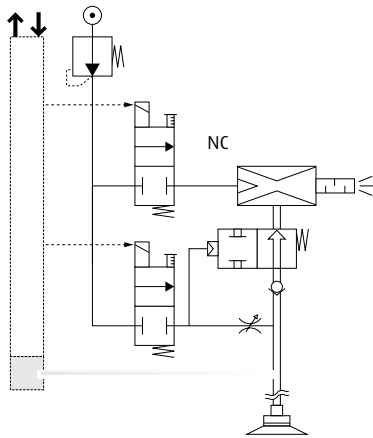

Solenoid valve NO

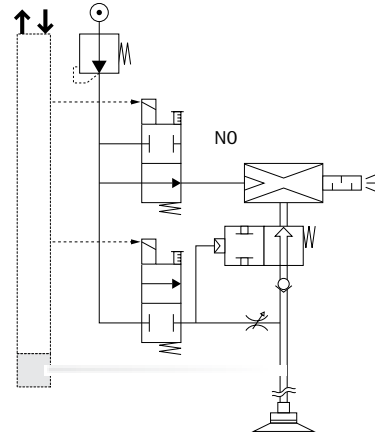

Operating principle EMA series

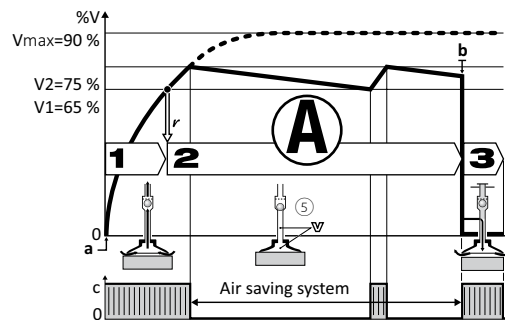
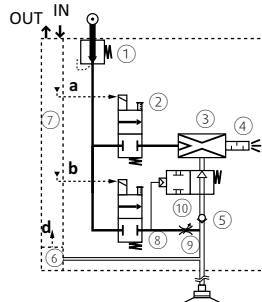
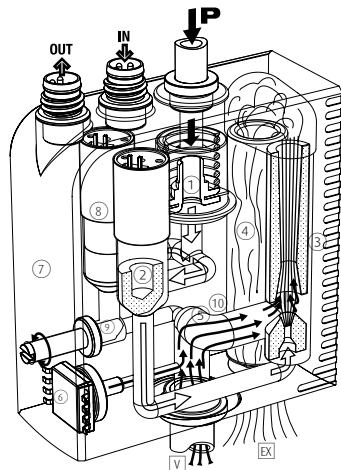

1. Gripping the workpiece

The vacuum solenoid valve ② starts the cycle. Venturi nozzle ③ is supplied with compressed air and generates the vacuum to grip the item quickly with the vacuum cup → short-term energy consumption.

2. Operations on the suctioned item

The vacuum level is continually monitored by the vacuum switch ⑥. When the vacuum threshold limit V1 (65 %) is reached the signal "Item gripped" is triggered. This gives a green light for the scheduled operation (transfer, processing etc.). When the vacuum reaches the threshold limit V2 (75 %), the compressed air supply to the venturi nozzles via the solenoid valve ⑤ is interrupted. Energy consumption falls to zero. The item remains gripped because of the vacuum that remains because of the closed non-return valve. Tiny leakages often lead to a slow release of the vacuum. If the vacuum falls to the threshold limit of 65 %, new vacuum is briefly generated, i.e. until the threshold limit V2 (75 %) is reached.

3. Releasing the workpiece

At the end of the procedures blow-off is triggered. The blow-off valve ⑧ generates an air jet that closes the closing valve ⑩. This blows off the item using the air pressure regulator ⑨ so that it can be released more quickly.



Nozzle diameter and energy saving potential

Air saving control cycle self-adaptation

Cycle 1:
Deals with an air tight product under the influence of LSA, resulting in optimum energy savings.

Cycle 2:
The porous product generates leaks that provoke repeated intermittent vacuum regeneration. The anomaly is automatically detected, and the cycle goes on but without LSA. An LSA missing signal is then emitted and displayed, and production goes on.

Cycle 3:
Illustrates the automatic return to the LSA cycle as soon as leaks are eliminated due to air tight products. Vacuum level will be maintained.

The compact-ejector EMA thus provides maximum energy saving, without any limitations to the performance and functioning of the overall production system.

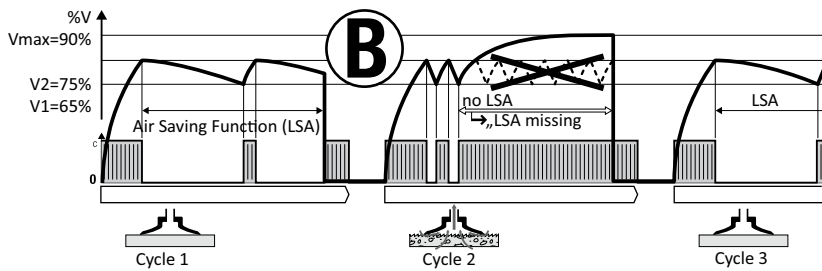

Without automatic air saving system			With automatic air saving system		
Nozzle diameter [mm]	Suction power [NI/min]	Air consumption [NI/min]	Suction duration (65 % vacuum) [sec]	Suction duration (75 % vacuum) [sec]	Air consumption [NI/min]
1	29	44	2.38	3.33	2.2
1.2	45	65	1.53	2.15	2.2
1.4	70	90	0.99	1.38	2.2

> Automatic air saving system activation allows a larger tube diameter to grip more quickly without increased consumption.

Example of the air saving potential

The examples show how the automatic air saving function reduces the energy demand:
 > 75 % energy saved during product transfer
 > 97 % energy saved during holding products while they are further processed or treated
 The investment will often amortise itself within a couple of months.

Gripping + Transfer (Nozzle Ø 1.4 mm, Evacuation of 0.2 l)

Phase	Duration	Air consumption		air saving potential
		without "LSA"	with "LSA"	
Grip	0.28 s	0.4 NI	0.4 NI	75 %
Transfer	1.20 s	1.8 NI	0	
Placement	0.14 s	0.2 NI	0.2 NI	
		2.4 NI	0.6 NI	

Fixation + Operation process (Nozzle Ø 1.4 mm, Evacuation of 0.4 l)

Phase	Duration	Air consumption		air saving potential
		without "LSA"	with "LSA"	
Fixation	0.55 s	0.8 NI	0.8 NI	97 %
Operation process	60 s	90 NI	0	
Placement	0.14 s	0.2 NI	0.2 NI	
		91 NI	1.0 NI	

Continued on the next page →



Vacuum generation | Compact ejectors

Ejectors with air saving function EMA

Wiring diagram

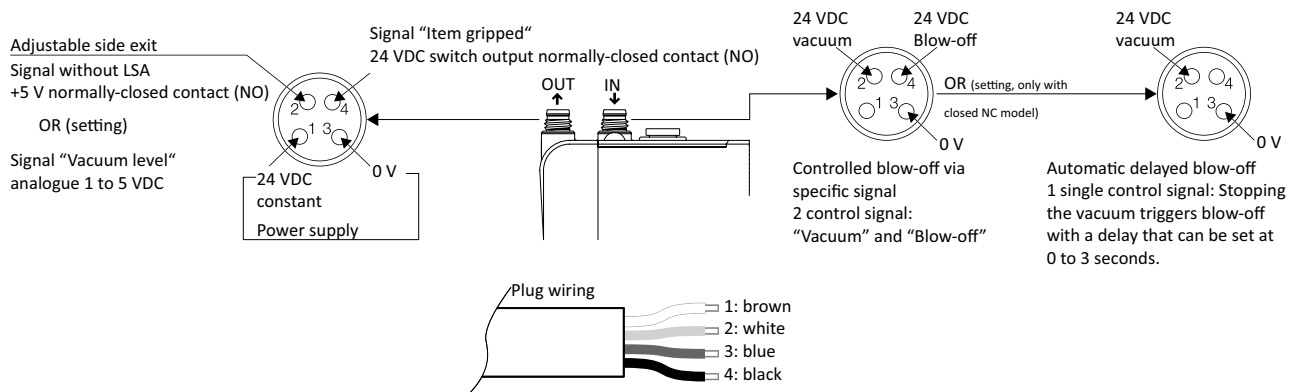

- > Output signal "object gripped", 24 VDC, switching output NO, switching current 125 mA, PNP
- > Adjustable side output:
 1. Signal without air saving function, +5 V switching output NO: eg. signal for failure indication
 2. Signal "vacuum level", analogue, 1-5 VDC of measuring range

Dimensions and mounting options

> Mounting sideways

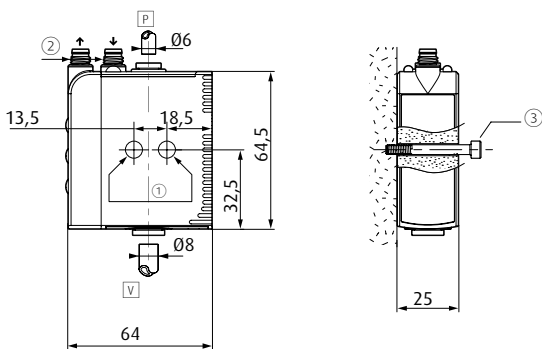

> Mounting in the front

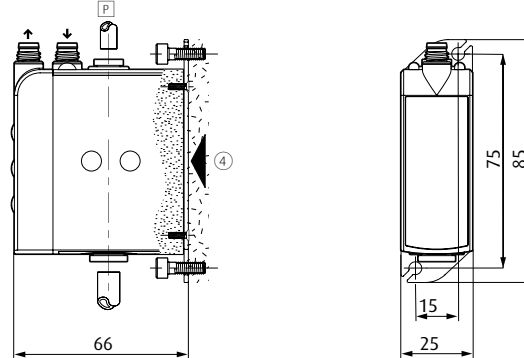

> Block mounting on a DIN rail

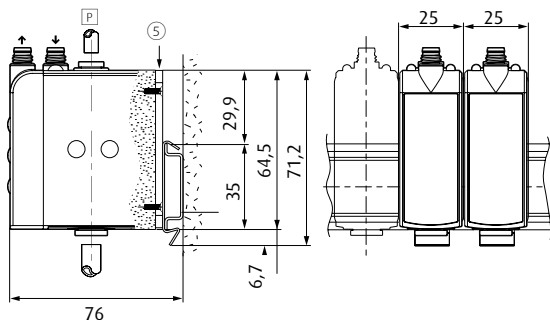

> EMA.FIX-B endpieces, with connecting screws and closing pins for collecting main

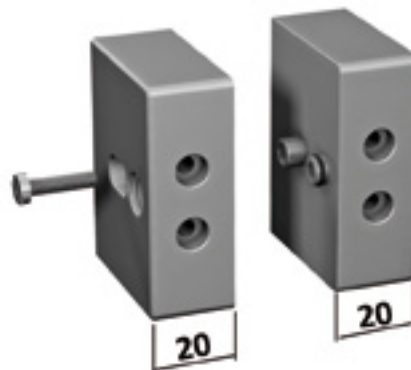

- P = Compressed air connection V = Vacuum connection ① = 2 Bore holes for 4 mm screws ② = M8 plug ③ = 2 Continuous screws
- ④ = Mounting plate with 4 screws (Item no. EMM.FIX-V)
- ⑤ = Mounting plate for DIN rail with 4 screws (Item no. EMM.FIX-D) - on plate per EMM-modul

Evacuation time [sec.] for 1 liter at vacuum level

Item no.	55 %	60 %	65 %	70 %	75 %	80 %
EMA.90x14	0.73	0.85	0.99	1.16	1.38	1.7



Ejectors with air saving function EKP and EKPP

Energy saving function by integrated pressure control



SAVES UP TO 50 % OF ENERGY



Check valve with wire mesh to keep out impurities

☐ = Vacuum connection P = Compressed air connection Ex = Exhaust outlet

Product Description

- > Handling of dense and porous workpieces
- > Within the supply pressure of 4 - 8 bar, the ejector works at 3.5 bar with same high performance
- > Electronic vacuum and blow-off control for short cycle times
- > Manual adjustment of the blow-off flow rate using a setscrew
- > Low noise emissions as, starting from 4 bar, outlet pressure is independent of inlet pressure
- > Open silencer further reduces the noise level and is completely maintenance-free

Notes

- > Ejector with digital vacuum switch 20.021 for process monitoring (Index „-VA“)
- > The vacuum switch can be freely adjusted after mounting the ejector

Ordering notes

- > Index EKP: with control valves
- > Index EKPP: without control valves
- > The performance data are identical for the two series
- > The optional check valve maintains the vacuum in cases of compressed air failure for a certain period of time to prevent sudden dropping of the workpiece
- > On request, ejectors are also available normally (current free) open (NO):
In case of power failure, compressed air line remains open and workpiece is held by the gripper

Technical data

Item no.	EKP.60x12	EKP.60x15	EKP.60x20	EKP.60x25	EKP.60x30	EKP.90x12	EKP.90x15	EKP.90x20	EKP.90x25	EKP.90x30
Nozzle diameter [mm]	1.2	1.5	2	2.5	3	1.2	1.5	2	2.5	3
Feed pressure [bar]	4 - 8	4 - 8	4 - 8	4 - 8	4 - 8	4 - 8	4 - 8	4 - 8	4 - 8	4 - 8
Internal working pressure [bar]	3.5	3.5	3.5	3.5	3.5	3.5	3.5	3.5	3.5	3.5
Final vacuum [%]	60	60	60	60	60	90	90	90	90	90
Suction power [Nl/min]	72	110	189	275	385	50	75	125	200	245
Air consumption [Nl/min]	65	97	179	200	385	65	97	179	260	385
Protection class	IP65	IP65	IP65	IP65	IP65	IP65	IP65	IP65	IP65	IP65
Operating principle	NC	NC	NC	NC	NC	NC	NC	NC	NC	NC
Control voltage	24 VDC (adjusted) ± 10 %	24 VDC (adjusted) ± 10 %	24 VDC (adjusted) ± 10 %	24 VDC (adjusted) ± 10 %	24 VDC (adjusted) ± 10 %	24 VDC (adjusted) ± 10 %	24 VDC (adjusted) ± 10 %	24 VDC (adjusted) ± 10 %	24 VDC (adjusted) ± 10 %	24 VDC (adjusted) ± 10 %
Current consumption for vacuum and blow-off feature [mA]	30 (0.7 W)	30 (0.7 W)	30 (0.7 W)	30 (0.7 W)	30 (0.7 W)	30 (0.7 W)	30 (0.7 W)	30 (0.7 W)	30 (0.7 W)	30 (0.7 W)

Continued on the next page →



Vacuum generation | Compact ejectors

Ejectors with air saving function EKP and EKPP

Technical data

Item no.	EKP.60x12	EKP.60x15	EKP.60x20	EKP.60x25	EKP.60x30	EKP.90x12	EKP.90x15	EKP.90x20	EKP.90x25	EKP.90x30
Operating temperature [°C]	10 - 60	10 - 60	10 - 60	10 - 60	10 - 60	10 - 60	10 - 60	10 - 60	10 - 60	10 - 60
Weight [g]	250	250	250	250	250	250	250	250	250	250
Suitable accessories	Connector cable 20.518 (p.717) Connector cable 20.519 (p.717) Check valve 32.658									

When ordering please specify

Type + Vacuum level + Nozzle diameter + Composition of module + Vacuum switch = Item number

Example: **EKP.90x12-AVA**

(Compact ejector EKP., vacuum level 90 %, nozzle diameter 1.2 mm, with controlled blow-off function and with electric vacuum switch with display)

1.: Type	2.: Vacuum level		3.: Nozzle diameter		4.: Composition of module		5.: Vacuum switch		6.: Optional
EKP	60	max. 60 % vacuum (porous products)	12	Ø 1.2 mm	-E	without blow-off-function	VA	digital with display	-NO (normally open)
			15	Ø 1.5 mm	-A	with controlled blow-off-function			
			20	Ø 2 mm					
	25	Ø 2.5 mm	-Z	with automatic blow-off-function with time release 0-3 sec.					
	30	Ø 3 mm			VO	without vacuum switch			

Example: **EKPP.60x15-VA:**

(Compact ejector EKPP vacuum level 60 %, nozzle diameter 1.5 mm, without additional function)

1.: Model without vacuum- / blow-off control	2.: Vacuum level		3.: Nozzle diameter		4.: Vacuum switch	
EKPP.	60	max. 60 % vacuum (porous products)	12	Ø 1.2 mm	-VA	digital with display
			15	Ø 1.5 mm		
			20	Ø 2 mm	-VO	without vacuum switch
	25	Ø 2.5 mm				
	30	Ø 3 mm				

Suitable connector cables for vacuum switch:

20.501: M8 thread, female, 4-pin, straight plug, cable length 5 m
20.502: M8 thread, female, 4-pin, 90° elbow plug, cable length 5 m

Suitable connector cables for EKP for vacuum valve and blow-off control:

20.518: M12 thread, female, 4-pin, straight plug, cable length 2 m
20.519: M12 thread, female, 4-pin, 90° elbow plug, cable length 2 m



Display of the energy saving potential by integrated pressure control

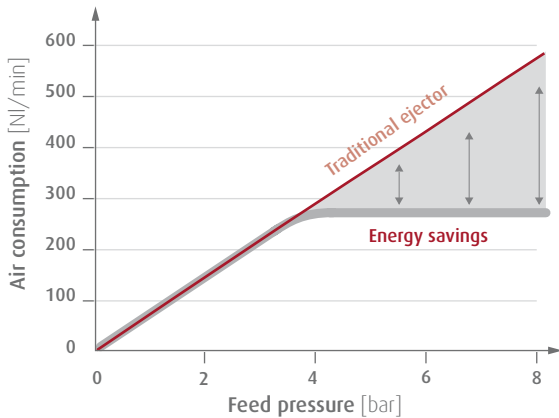

Example of EKP.90x25 resp. EKP.60x25

Pneumatic Diagram

Ejector without blow-off-function
EKP_ X _ EV _

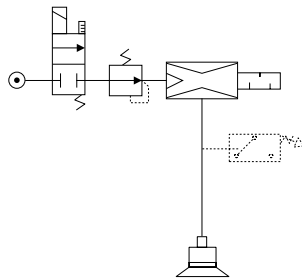

- > Basic product
- > Only one control signal

Ejector with controlled blow-off-function
EKP_ X _ AV _

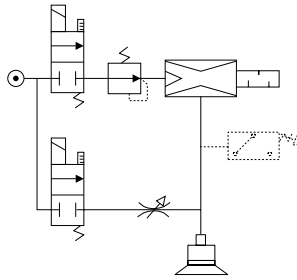

- > Control of blow-off-function through outer signal with screw to adjust blow-off-volume
- > Two control signals

Ejector with automatic blow-off-function with time release
EKP_ X _ ZV _

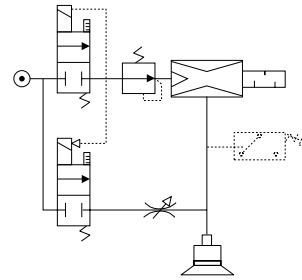

- > Automatic blow-off when ejector is switched off, delay of blow-off can be manually set between 0 and 3 s, with adjusting screw
- > Only one control signal

Electric plug / Vacuum switch

Electric connection EKP

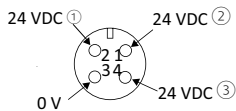

- ① = Control of vacuum
- ② = Permanent (version Z)
- ③ = Blow-off-control (version A)

Ejectors with electronic (digital) vacuum switch
EKP-VA with display, 2 outputs

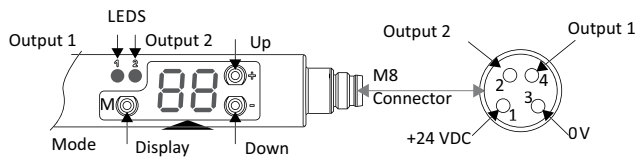

- > Ejectors without vacuum switch EKP-V0: This type needs to be complemented by an independent vacuum switch in the vacuum system or, during evacuation of a manually controlled volume, by a vacuum gauge.

Continued on the next page →



Vacuum generation | Compact ejectors

Ejectors with air saving function EKP and EKPP

Dimensions

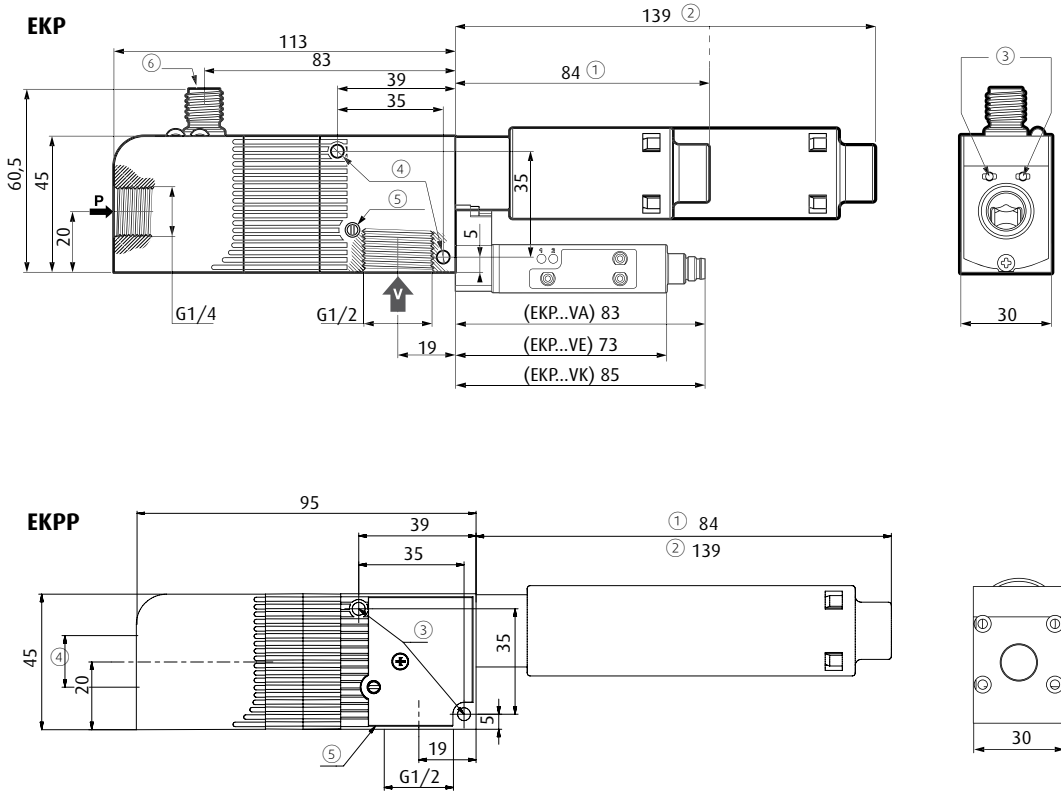

① = Silencers for nozzle \varnothing 1.2 or 1.5 mm ② = Silencers for nozzle \varnothing 2 - 2.5 or 3 mm ③ = Manual vacuum and blow-off control
 ④ = Mounting \varnothing 4.2 mm ⑤ = Adjusting blow-off power

Diagrams

> Vacuum level against feed pressure

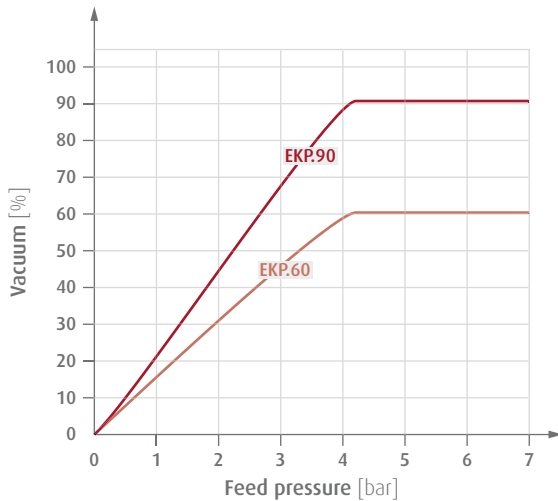

> Air consumption against feed pressure

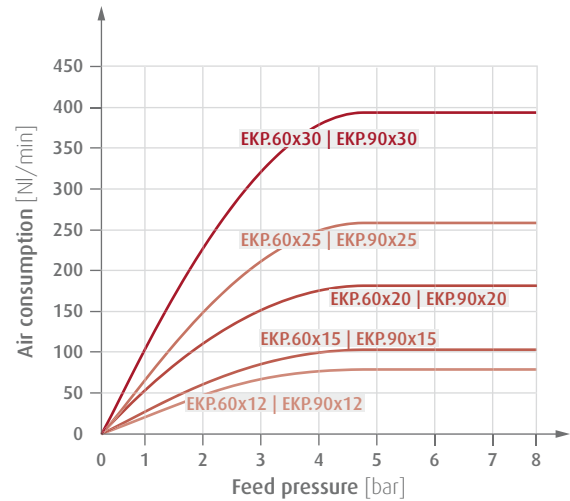



Diagrams

> Suction power against vacuum level

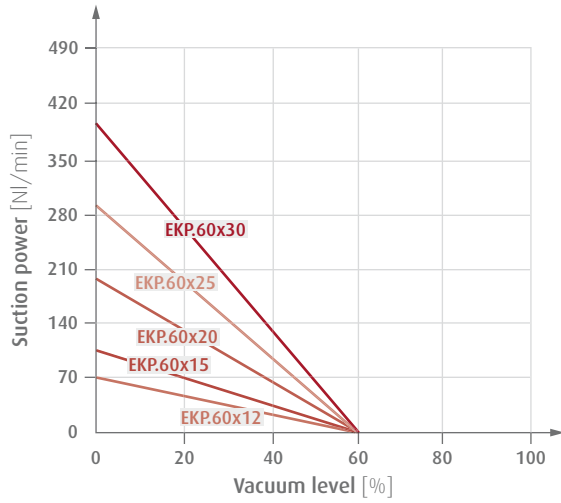

> Suction power against feed pressure

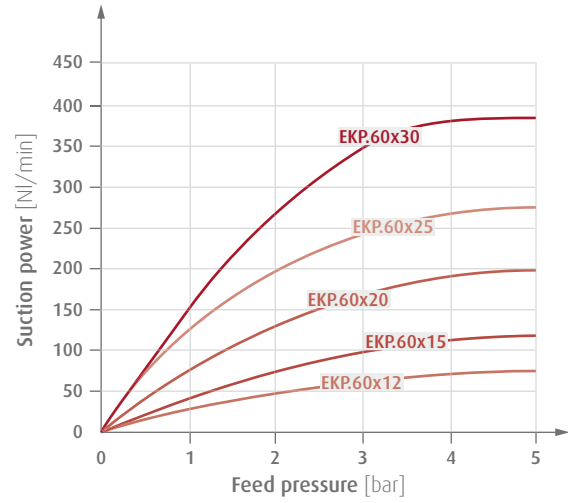

> Suction power against vacuum level

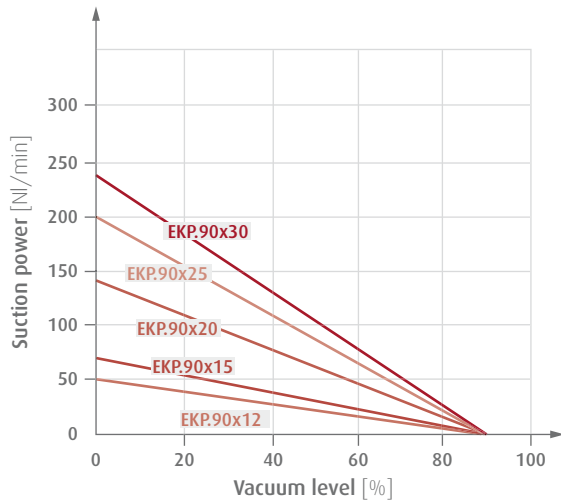

> Suction power against feed pressure

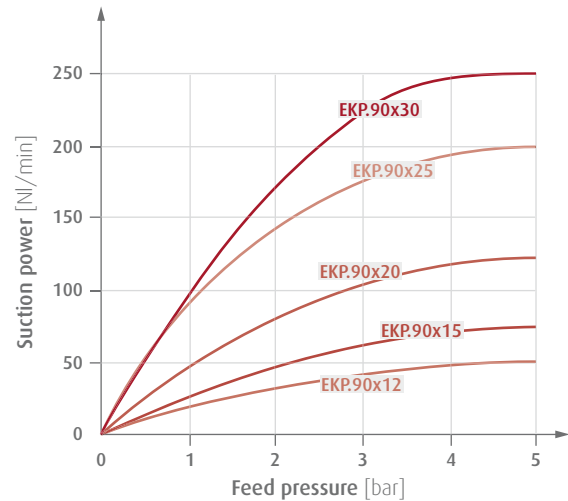

Evacuation time [sec.] for 1 liter at vacuum level

Item no.	10 %	20 %	30 %	40 %	50 %	60 %	70 %	80 %	85 %
EKP.60x12	0.09	0.2	0.35	0.55	0.9	--	--	--	--
EKP.60x15	0.06	0.14	0.23	0.36	0.59	--	--	--	--
EKP.60x20	0.04	0.08	0.13	0.21	0.34	--	--	--	--
EKP.60x25	0.03	0.05	0.09	0.14	0.24	--	--	--	--
EKP.60x30	0.01	0.04	0.07	0.1	0.17	--	--	--	--
EKP.90x12	0.13	0.27	0.44	0.64	0.88	1.19	1.62	2.37	3.12
EKP.90x15	0.09	0.18	0.29	0.42	0.58	0.79	1.08	1.59	2.08
EKP.90x20	0.05	0.11	0.18	0.25	0.35	0.46	0.65	0.95	1.25
EKP.90x25	0.03	0.07	0.11	0.16	0.22	0.3	0.41	0.59	0.78
EKP.90x30	0.03	0.06	0.09	0.13	0.18	0.24	0.33	0.48	0.64



Notes:

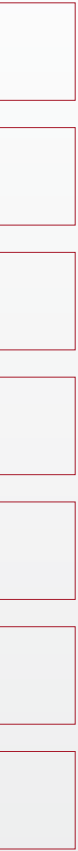

Lined writing area for notes



FIPA Feed ejectors

- > Secure transport of bulk material
- > Extraction of non-aggressive gases or steams
- > Ideal source of vacuum in applications with high leakage



Feed ejectors for large throughput

- > Contamination-resistant construction for reliable operation, even under harsh operating conditions

65.701 - 65.731

- > High vacuum level
- > For overcoming larger height differences
- > Suction volume and vacuum level can be adapted to level of compressed air pressure



65.742 - 85.802

- > Low vacuum level
- > For overcoming smaller height differences
- > Suction volume and vacuum level dependent on level of compressed air pressure

> See page 570



Feed ejectors for small throughput EFO

- > Low suction power due to medium vacuum levels
- > Various connections for inlets and outlets as well as for compressed air supply
- > Suitable filters or collection vessels available as accessories

> See page 574

Examples of use

- > Gentle product feeding thanks to axial arrangement of inlet and outlet
- > Vacuum supply for vacuum cups used to handle porous workpieces, or for a high degree of leakage
- > Electricity-free alternative to motor-driven vacuum pumps or side channel blowers
- > Continual operation without heat development as there are no moving parts

Functional principle

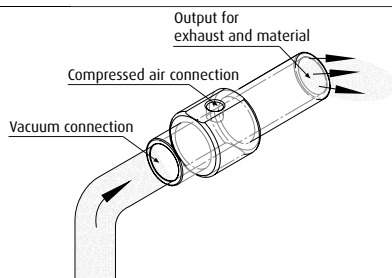



Feed ejectors - rotatable

High suction power for handling with high leakage

ALSO AVAILABLE IN STAINLESS STEEL FOR FOOD INDUSTRY OR ABRASIVE MEDIA



Product Description

- > High suction power for safe handling of air-permeable products or generally in the presence of high leakage
- > Gentle transportation of powdery substances or small-size products such as granular material, coffee, flour
- > Extraction of non-aggressive vapors and gases
- > Volume of suction air and required vacuum level can be adjusted by turning the suction pipe, allowing for an energy efficient increase in performance without increasing air consumption
- > Can even be used in rough conditions thanks to the robust, maintenance-free construction without moving parts
- > No build-up of heat because of no moving parts and therefore no risk of ignition during transport
- > High maximum vacuum level for over coming larger height differences
- > Stainless steel designs for easy cleaning when transporting foods and for handling abrasive media
- > Extremely flexible integration into gripper systems thanks to any mounting position

Notes

- > The transport length depends on the feed pressure, the transport volume and the transport goods
- > Rule of thumb:
 - Tubing length from suction point to ejector ~ 2/3 of the total tubing length
 - Tubing length from ejector to point of use ~ 1/3 of the total tubing length
- > Prior to installation a test at customer site is recommended
- > For longer distances, multiple ejectors can be serially connected

Technical data

Item no.	Nozzle diameter [mm]	Pressure range [bar]	Optimal feed pressure [bar]	Final vacuum [mbar]	Suction power [Nl/min]	Air consumption [Nl/min]	Operating temperature [°C]	Weight [g]	Material	Suitable silencers
65.701	7	4 - 7	5	850	0 - 284	0 - 235	-20 - 80	105	Aluminium anodised	72.029 (p.577)
65.711	10	4 - 7	5	850	0 - 848	0 - 481	-20 - 80	275	Aluminium anodised	72.031 (p.577)
65.731	20	4 - 7	5	850	0 - 3,402	0 - 1,246	-20 - 80	550	Aluminium anodised	72.033 (p.577)
65.701-S	7	4 - 7	5	850	0 - 284	0 - 235	-20 - 80	300	Stainless steel	72.029 (p.577)
65.711-S	10	4 - 7	5	850	0 - 848	0 - 481	-20 - 80	700	Stainless steel	72.031 (p.577)
65.731-S	20	4 - 7	5	850	0 - 3,402	0 - 1,246	-20 - 80	1,500	Stainless steel	72.033 (p.577)

Functional principle

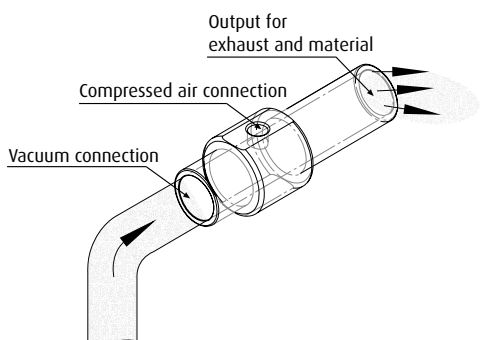



Air consumption [NI/min] at vacuum level (feed pressure 5.5 bar)

Item no.	17 %	34 %	50 %	68 %	84 %
65.701	112	169	233	276	342
65.711	176	327	485	595	825
65.731	650	875	1250	1790	2550
65.701-S	112	169	233	276	342
65.711-S	176	327	485	595	825
65.731-S	650	875	1250	1790	2550

Suction power [NI/min] at vacuum level (feed pressure 5.5 bar)

Item no.	17 %	34 %	50 %	68 %	84 %
65.701	280	240	200	162	125
65.711	846	735	620	520	395
65.731	3390	2460	1970	1440	1130
65.701-S	280	240	200	162	125
65.711-S	846	735	620	520	395
65.731-S	3390	2460	1970	1440	1130

Dimensions

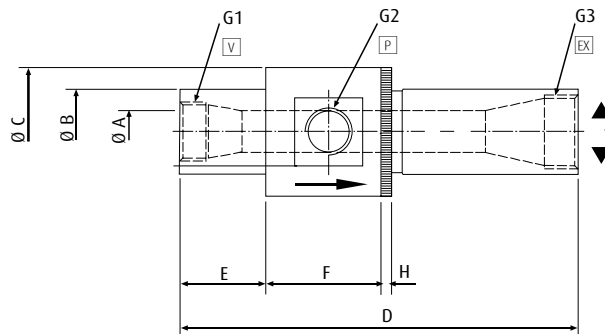

V = Vacuum connection
 P = Compressed air connection
 EX = Exhaust outlet
 * = rotatable

Item no.	G1	G2	G3	Ø A [mm]	Ø B [mm]	Ø C [mm]	D [mm]	E [mm]	F [mm]	H [mm]
65.701	G1/4	G1/8	G1/4	7	18.8	32	94 - 105	22	31.5	5
65.711	G1/2	G3/8	G1/2	10	25.1	51	155 - 165	38.1	44.2	5
65.731	G3/4	G1/2	G1	20	37.8	58	175 - 189	38.1	56.4	5
65.701-S	G1/4	G1/8	G1/4	7	18.8	32	94 - 105	22.1	31.5	5
65.711-S	G1/2	G3/8	G1/2	10	25.1	51	155 - 165	38.1	44.2	5
65.731-S	G3/4	G1/2	G1	20	37.8	58	175 - 189	38.1	56.4	5



Feed ejectors - with a large passage

Very high suction power for high transportation throughput



Product Description

- > Very high suction power for high transportation throughput
- > Gentle transportation of powdery substances or small-size products such as granular material, pills, chippings
- > Extraction of non-aggressive vapors and gases
- > Can even be used in rough conditions thanks to the robust, maintenance-free construction
- > No build-up of heat because of no moving parts and therefore no risk of ignition during transport
- > Extremely flexible integration into gripper systems thanks to any mounting position

Notes

- > The transport length depends on the feed pressure, the transport volume and the transport goods
- > Rule of thumb:
 - Tubing length from suction point to ejector ~ 2/3 of the total tubing length
 - Tubing length from ejector to point of use ~ 1/3 of the total tubing length
- > Prior to installation a test at customer site is recommended
- > For longer distances, multiple ejectors can be serially connected

Ordering notes

- > Mounting options:
65.752: Connections for vacuum and outlet on both sides using G3/8 female thread (see drawing)

Technical data

Item no.	Nozzle diameter [mm]	Pressure range [bar]	Max. feed pressure [bar]	Final vacuum [mbar]	Suction power at 5.5 bar [Nl/min]	Air consumption at 2.8 bar [Nl/min]	Air consumption at 5.5 bar [Nl/min]	Operating temperature [°C]	Weight [g]	Material	Suitable silencers
65.742	7	2.5 - 6	7	260	295	85	160	-10 - 80	92	Aluminium anodised	--
65.752	10	2.5 - 6	7	160	425	95	170	-10 - 80	81	Aluminium anodised	72.030 (p.577)
65.762	13	2.5 - 6	7	350	870	395	680	-10 - 80	177	Aluminium anodised	--
65.772	19	2.5 - 6	7	280	1,825	790	1,365	-10 - 80	380	Aluminium anodised	--
65.792	38	2.5 - 6	7	90	4,400	405	695	-10 - 80	607	Aluminium anodised	--
65.802	38	2.5 - 6	7	90	5,610	790	1,356	-10 - 80	777	Aluminium anodised	--



Functional principle

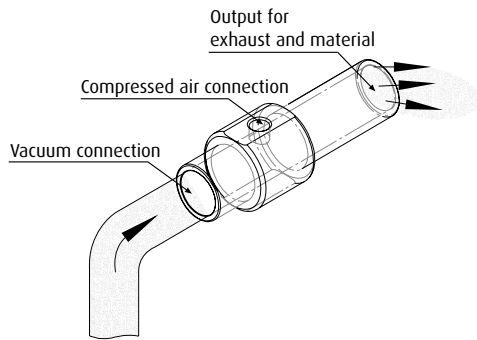

Dimensions

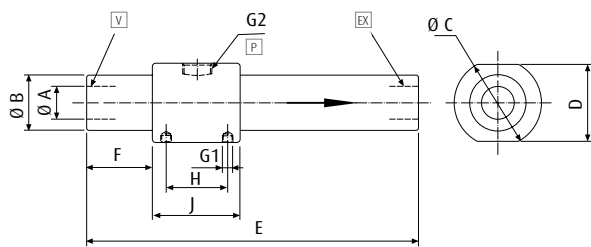

65.742 | 65.762 | 65.772 | 65.792 | 65.802

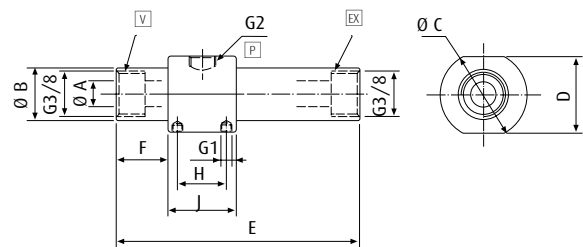

65.752

V = Vacuum connection P = Compressed air connection EX = Exhaust outlet

Item no.	G1	G2	Ø A [mm]	Ø B [mm]	Ø C [mm]	D [mm]	E [mm]	F [mm]	H [mm]	J [mm]
65.742	M4	G1/8	6.5	18.5	32	30	89	19	18	25
65.752	M4	G1/8	9.5	18.5	32	30	89	19	18	25
65.762	M4	G1/4	12.5	24	38	34	140	25.5	23	32
65.772	M6	G3/8	19	32	50	45	190	38	35	50
65.792	M6	G3/8	38	50	69	65	205	40	42	60
65.802	M6	G3/8	38	50	69	65	205	40	42	60



Vacuum generation | Feed ejectors

Feed ejectors EFO - with a small passage

Feed ejectors EFO - with a small passage

Compressed air connection via quick fittings, outlet via R-threads, exhaust via R-threads or quick fittings



Exhaust via R-threads



Exhaust via tubing connection

V = Vacuum connection P = Compressed air connection Ex = Output

Product Description

- > Transport of powdery or granular materials
- > Extraction of non-aggressive vapors and gases
- > Medium vacuum level for overcoming larger height differences
- > No build-up of heat because of no moving parts and therefore no risk of ignition during transport
- > Maximum availability thanks to robust, maintenance-free design
- > Rotatable, angled compressed air connection and any mounting position for flexible system integration

Notes

- > The transport length depends on the feed pressure, the transport volume and the transport goods
- > Rule of thumb:
 - Tubing length from suction point to ejector ~ 2/3 of the total tubing length
 - Tubing length from ejector to point of use ~ 1/3 of the total tubing length
- > Prior to installation a test at customer site is recommended
- > For longer distances, multiple ejectors can be serially connected

Technical data

Item no.	Series	Nozzle diameter [mm]	Optimal feed pressure [bar]	Pressure range [bar]	∅ Free passage [mm]	Final vacuum [%]	Suction power at 5 bar [Nl/min]	Air consumption [Nl/min]	Operating temperature [°C]	Weight [g]	Material
EFO.30L.1	With R-thread	3	5	0 - 10	2.3	52	50	50	0 - 60	41	Aluminium anodised
EFO.40L.1	With R-thread	4	5	0 - 10	3.6	52	100	100	0 - 60	81	Aluminium anodised
EFO.60L.1	With R-thread	6	5	0 - 10	5.5	52	200	200	0 - 60	190	Aluminium anodised
EFO.75L.1	With R-thread	7.5	5	0 - 10	7	52	300	300	0 - 60	193	Aluminium anodised
EFO.30L.2	With tubing connection	3	5	0 - 10	2.3	52	50	50	0 - 60	37.5	Aluminium anodised
EFO.40L.2	With tubing connection	4	5	0 - 10	3.6	52	100	100	0 - 60	77	Aluminium anodised
EFO.60L.2	With tubing connection	6	5	0 - 10	5.5	52	200	200	0 - 60	182	Aluminium anodised
EFO.75L.2	With tubing connection	7.5	5	0 - 10	7	52	300	300	0 - 60	183	Aluminium anodised



Dimensions

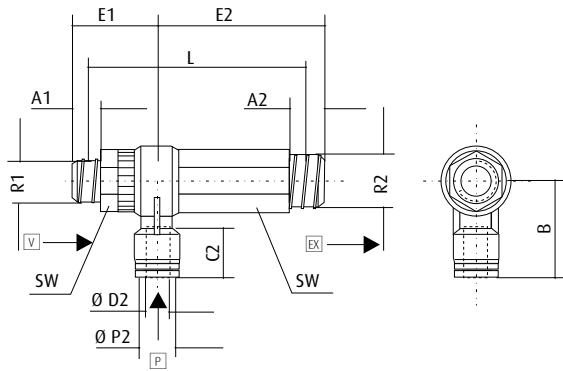

EFO.30L.1 | EFO.40L.1 | EFO.60L.1 | EFO.75L.1

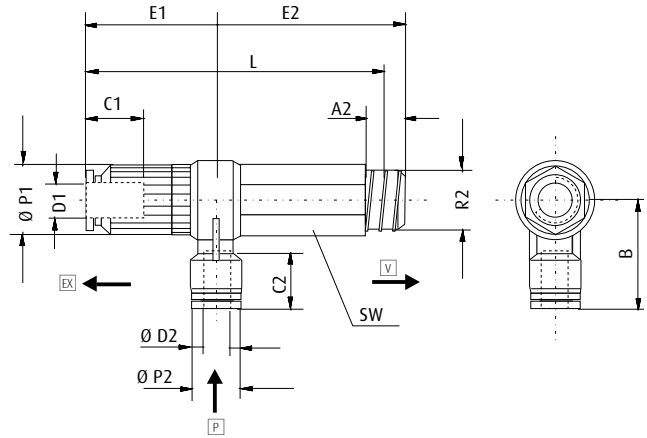

EFO.30L.2 | EFO.40L.2 | EFO.60L.2 | EFO.75L.2

V = Vacuum connection P = Compressed air connection EX = Output

Item no.	R1	R2	A1 [mm]	A2 [mm]	B [mm]	C1 [mm]	C2 [mm]	Ø D1 [mm]	Ø D2 [mm]	E1 [mm]	E2 [mm]	L [mm]	Ø P1 [mm]	Ø P2 [mm]	SW
EFO.30L.1	R1/8	R1/8	8	8	25	--	16.5	--	6	23	36	51	--	12.5	14
EFO.40L.1	R1/4	R1/4	11	11	29	--	17.5	--	8	29.5	53	70	--	14.5	17
EFO.60L.1	R3/8	R1/2	12	15	34	--	20	--	10	35	69.5	90	--	17.5	22
EFO.75L.1	R1/2	R1/2	15	15	34	--	20	--	10	38	69.5	91.5	--	17.5	24
EFO.30L.2	--	R1/8	--	8	25	17.5	16.5	8	6	30	36	62	16	12.5	14
EFO.40L.2	--	R1/4	--	11	29	20	17.5	10	8	35.5	53	82.5	20	14.5	17
EFO.60L.2	--	R1/2	--	15	34	23.5	20	12	10	43.5	69.5	105	25	17.5	24
EFO.75L.2	--	R1/2	--	15	34	25	20	16	10	45	69.5	106.5	25	17.5	24



Vacuum generation | Feed ejectors

Feed ejectors EFO - with a small passage

Feed ejectors EFO - with a small passage

Compressed air, vacuum and exhaust side with quick fittings



V = Vacuum connection **P** = Compressed air connection **Ex** = Output

Product Description

- > Transport of powdery or granular materials
- > Extraction of non-aggressive vapors and gases
- > Medium vacuum level for overcoming larger height differences
- > No build-up of heat because of no moving parts and therefore no risk of ignition during transport
- > Maximum availability thanks to robust, maintenance-free design
- > Rotatable, angled compressed air connection and any mounting position for flexible system integration

Notes

- > The transport length depends on the feed pressure, the transport volume and the transport goods
- > Rule of thumb:
 - Tubing length from suction point to ejector ~ 2/3 of the total tubing length
 - Tubing length from ejector to point of use ~ 1/3 of the total tubing length
- > Prior to installation a test at customer site is recommended
- > For longer distances, multiple ejectors can be serially connected

Technical data

Item no.	Nozzle diameter [mm]	Optimal feed pressure [bar]	Pressure range [bar]	Ø Free passage [mm]	Final vacuum [%]	Suction power at 5 bar [Nl/min]	Air consumption [Nl/min]	Operating temperature [°C]	Weight [g]
EFO.30L.3	3	5	0 - 10	2.3	52	50	50	0 - 60	49
EFO.40L.3	4	5	0 - 10	3.6	52	100	100	0 - 60	101.5
EFO.60L.3	6	5	0 - 10	5.5	52	200	200	0 - 60	186
EFO.75L.3	7.5	5	0 - 10	7	52	300	300	0 - 60	176.5

Dimensions

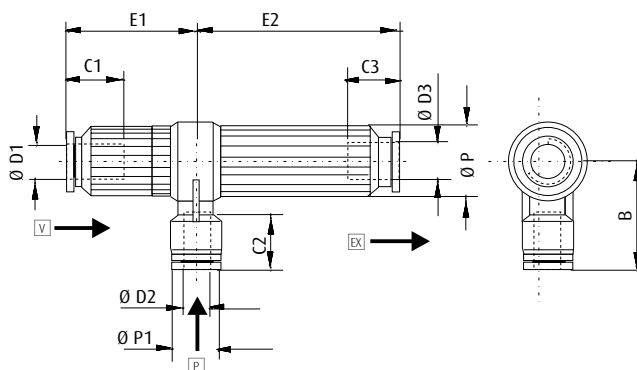

V = Vacuum connection **P** = Compressed air connection **Ex** = Exhaust outlet

Item no.	Ø D1 [mm]	Ø D2 [mm]	Ø D3 [mm]	B [mm]	C1 [mm]	C2 [mm]	C3 [mm]	E1 [mm]	E2 [mm]	Ø P [mm]	Ø P1 [mm]
EFO.30L.3	8	6	8	25	17.5	16.5	17.5	30	55	16	12.5
EFO.40L.3	10	8	12	29	20	17.5	23.5	35.5	76.5	20	14.5
EFO.60L.3	12	10	16	34	23.5	20	25	43.5	74.5	25	17.5
EFO.75L.3	16	10	16	34	25	20	25	45	74.5	25	17.5



Open silencers for ejectors



Product Description

- > Suitable for Heavy-duty ejectors or inline ejectors ELL, expandable
- > Open design, specially suitable for dusty, high-particle environments (e.g. wood industry)

Technical data

Item no.	Weight [g]
72.028	3
72.029	20
72.030	25
72.031	35
72.032	55
72.033	175

Dimensions

G	$\varnothing D$ [mm]	$\varnothing Di$ [mm]	L [mm]	L1 [mm]	L2 [mm]
G1/8	14	7	46	41	5
G1/4	20	11	73	65	8
G3/8	24	11	72	64	8
G1/2	30	17	128	121	7
G3/4	40	17	126	119	7
G1	49	26	126	119	7

Dimensions

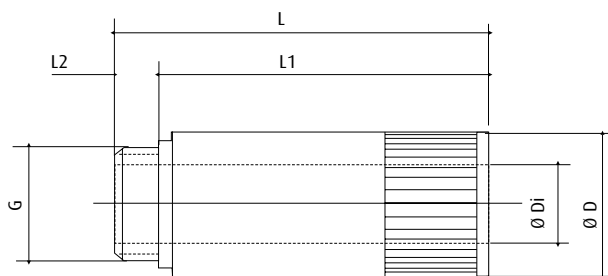



Closed silencers for ejectors



Product Description

- > Closed diffusor / silencer specially designed for dust-free environments
- > Suitable for Heavy-duty ejectors or inline ejectors EIL, expandable

Technical data

Item no.	Weight [g]
72.045	5
72.000	2
72.001	3.5
72.002	12
72.003	15
72.007	5.5
72.008	3
72.009	6.5

Dimensions

G1	Ø D [mm]	A [mm]	Ø B [mm]	C [mm]	Ø P [mm]
M5	--	36	18	5.1	--
G1/8	--	28	15.5	6	15.5
G1/4	--	38	17.5	8	17.5
G3/8	--	58	26	10	26.5
G1/2	--	66	29	12	29
--	4	30	--	11	10.5
--	6	34.5	--	11.5	15.5
--	8	48.5	--	17.5	17.5

Dimensions

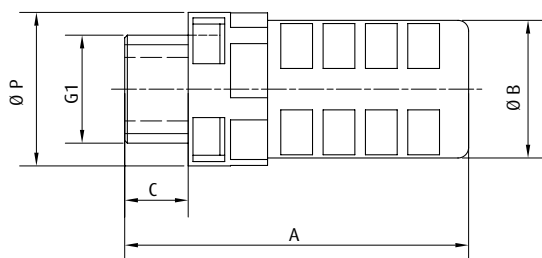

72.045 | 72.000 | 72.001 | 72.002 | 72.003

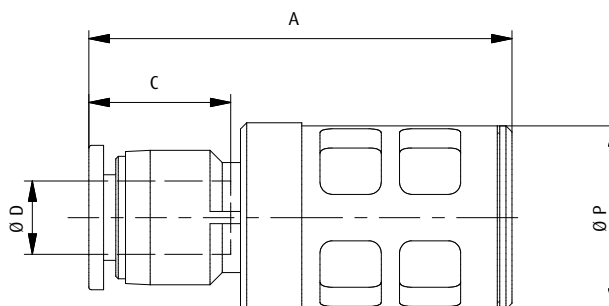

72.007 | 72.008 | 72.009



Silencers with filter function



Series 1: Brass construction with stainless steel wire fabric



Series 2: Brass construction with sintered material

Product Description

- > Combination of silencer and air filter
- > 72.015 - 72.021: Also suitable as protective filter for 3/2-way valves at ventilation / blow-off inlet (under contaminated environmental conditions)
- > 72.022 - 72.027: Can be mounted directly into the vacuum cup or the fitting, temperature resistant up to 120 °C

Technical data

Item no.	Series	Weight [g]
72.015	1	2
72.016	1	6
72.017	1	10
72.018	1	15
72.019	1	25
72.020	1	38
72.021	1	56
72.022	2	1
72.022-1*	2	1
72.023	2	3
72.024	2	6
72.025	2	12
72.026	2	16
72.027	2	29

Dimensions

G	B [mm]	Ø D [mm]	L [mm]	L1 [mm]	SW
M5	3.5	2.5	9.5	4	8
G1/8	4	6	14	6	13
G1/4	5	8.5	18.5	8	16
G3/8	6	11	19.5	8	19
G1/2	5	15	22.5	10	24
G3/4	6	20	25.5	10	30
G1	6.5	26	31	11.5	36
G1/8	--	5.5	4.5	3.5	--
G1/8	--	5.5	5	3.5	--
G1/4	--	7	6.8	4.5	--
G3/8	--	9.5	6.8	5	--
G1/2	--	12	9	7	--
G3/4	--	18	9	6.5	--
G1	--	23.5	10.5	7.5	--

Dimensions

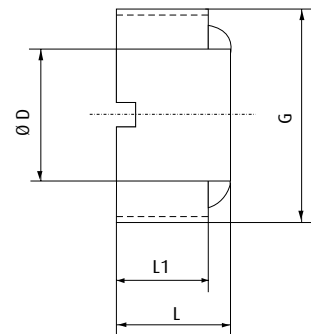
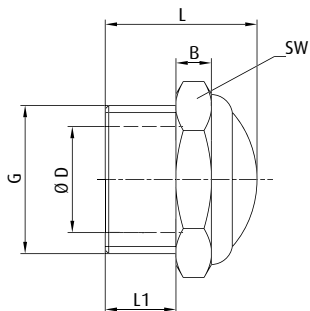

72.015 | 72.016 | 72.017 | 72.018 | 72.019 | 72.020 | 72.021

72.022 | 72.022-1* | 72.023 | 72.024 | 72.025 | 72.026 | 72.027

* = Special design: Coarse filter with mesh opening size 0.4 mm



FIPA Rotary vane vacuum pumps



Rotary vane vacuum pumps - oil-free

- > Handling of dense workpieces in dry areas
- > Suitable for load alternation and continuous operation
- > Available in single-phase and three-phase designs
- > Any installation position
- > Very low maintenance

> See page 582



Piston pumps

- > Small output at compact design
- > Suitable for dry and wet areas
- > Long-life and low maintenance thanks to the permanently lubricated piston seals
- > Oil-free operation
- > Also suitable as compressors

> See page 592



Rotary vane vacuum pumps - oil-lubricated

- > Handling dense and porous workpieces
- > Partially suitable for applications in wet areas
- > Suitable for continuous operation in product-dependent vacuum levels
- > Available in single-phase and three-phase designs
- > Horizontal installation position

> See page 594



Centralised vacuum units

- > Supply of several modules via a central station
- > Made up of one to three oil-lubricated vacuum pumps
- > Incl. vacuum tank and electronic control

> See page 606



FIPA rotary vane vacuum pumps



Accessories

Vacuum tanks

- > As storage device for compressed air, vacuums and non-aggressive liquids
- > Efficient compressed air/vacuum usage (energy saving, protection of the unit)
- > For compressed air/vacuum systems with highly fluctuating consumption

> See page 617

Vacuum generation according to the displacement principle

- > A cylindrical rotor ① rotates eccentrically in a circular cavity ②.
- > The rotary vanes ③ are pushed against the outer walls of the cavity by centrifugal force, sealing the chambers that are created by this motion.
- > During rotation, the expanding chambers draw in air on the vacuum side $\square V$.
- > The suctioned aspirated air is then released via the exhaust $\square Ex$.

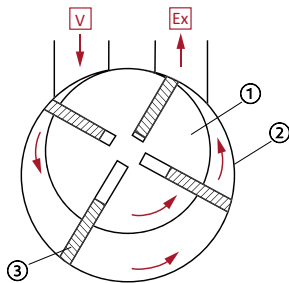

Performance characteristics

- (a) Characteristic of ejectors
- (b) Rotary vane vacuum pumps achieve a very good ultimate vacuum along with a high flow volume
- (c) Characteristic of side channel blowers

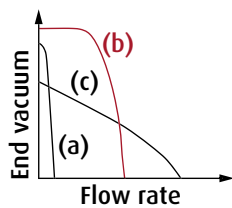



Rotary vane vacuum pumps - oil-free

Handling in dry areas



Product Description

- > High reliability and low maintenance costs owing to simple design
- > Universal application: Continuous operation at different vacuum levels
- > Compact design and low weight

Ordering notes

- > Available in single-phase and three-phase designs (Index -1 or -3)
- > Included in scope of delivery:
 - Silencer on suction side
 - DT.3C-1: Thermal protection 130 °C
 - DT.6, DT.10: Safety filter on suction side
- > Delivery without electric cables

Technical data

Item no.	DT.3A-1	DT.3A-3	DT.6B-1	DT.6B-3	DT.10B-1	DT.10B-3
Suction power at 50 Hz [m ³ /h]	3	3	6	6	10	10
Suction power at 60 Hz [m ³ /h]	3.3	3.3	7	7	12	12
Final vacuum [%]	88	88	88	88	88	88
Power supply at 50 (60) Hz [V]	220 - 240	Delta: 220-255 (220-266) Star: 380-440 (380-460)	220 - 240	Delta: 220-255 (220-266) Star: 380-440 (380-460)	220 - 240	Delta: 220-255 (220-266) Star: 380-440 (380-460)
Current consumption at 50 (60) Hz [A]	1 (1.1)	Delta: 0.7-0.8 (0.7) Star: 0.4-0.46 (0.38-0.42)	2.3 (2.5)	Delta: 1.4-1.5 (1.5-1.4) Star: 0.8-0.86 (0.86-0.8)	2.9 (2.7)	Delta: 1.8-2.3 (1.6-2.3) Star: 1-1.3 (0.9-1.3)
Rated power at 50 Hz [kW]	0.12	0.12	0.25	0.25	0.37	0.37
Rated power at 60 Hz [kW]	0.15	0.14	0.3	0.3	0.45	0.45
Noise level at 50 Hz [dB(A)]	62	62	60	60	64	64
Noise level at 60 Hz [dB(A)]	65	65	65	65	66	66
Operating temperature at 50 Hz [°C]	65 - 70	65 - 70	65 - 70	65 - 70	70 - 75	70 - 75
Operating temperature at 60 Hz [°C]	70 - 75	70 - 75	70 - 75	70 - 75	80 - 85	80 - 85
Weight [kg]	5	5	8.5	7.5	15.5	14
Suitable accessories	Spare part kit KIT-DT.3A* Vacuum regulator 73.002 (p.640) Pre-filter FC 10F (p.624) Pre-filter 71.032 (p.625)		Spare part kit KIT-DT.6B** Vacuum regulator 73.002 (p.640) Pre-filter FC 10F (p.624) Pre-filter 71.032 (p.625)		Spare part kit KIT-DT.10B*** Vacuum regulator 73.002 (p.640) Pre-filter FC 20F (p.624) Pre-filter 71.034 (p.625)	



Dimensions

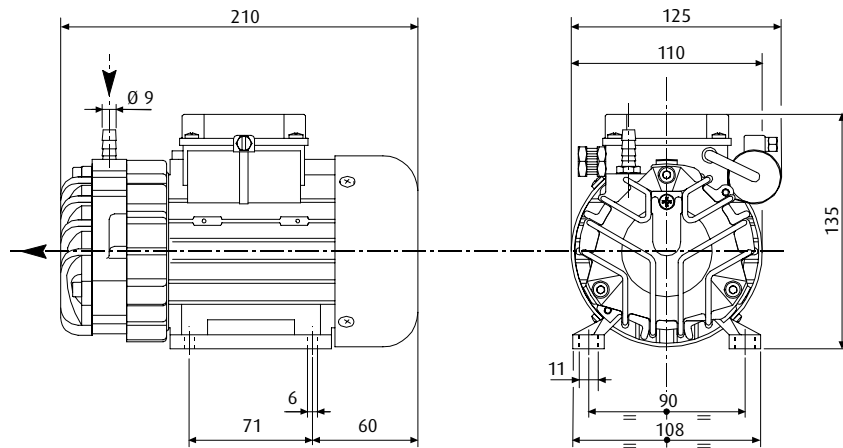

DT.3A-1 | DT.3A-3

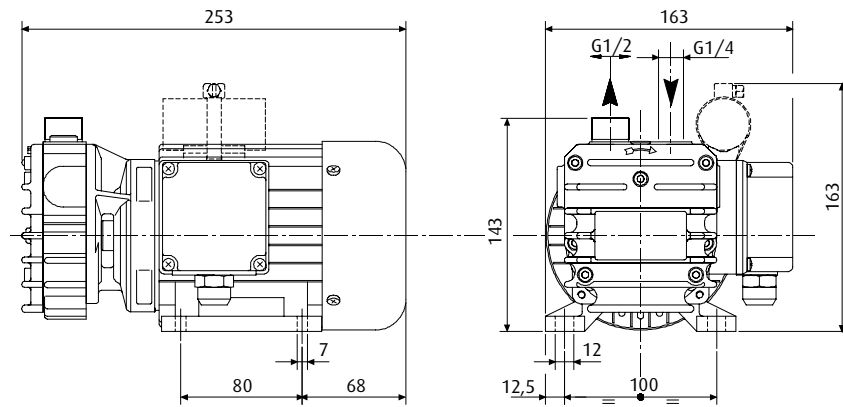

DT.6B-1 | DT.6B-3

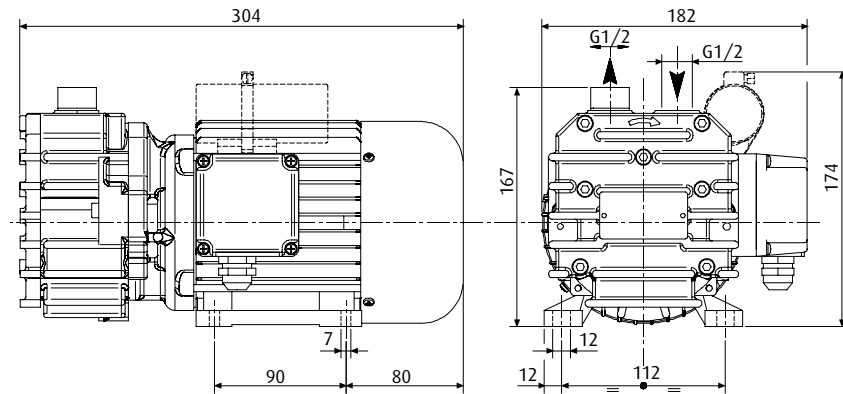

DT.10B-1 | DT.10B-3

* = 3 vanes, rotor ** = 4 vanes, rotor *** = 6 vanes, rotor

Continued on the next page →



Diagrams

> Suction power against vacuum level at 50 Hz

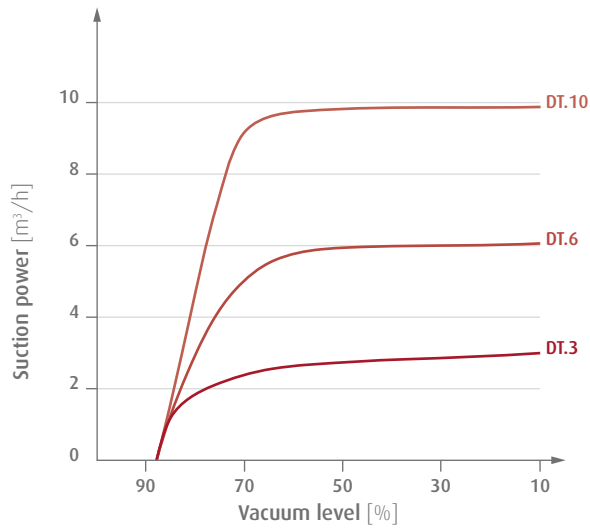

> Suction power against vacuum level at 60 Hz

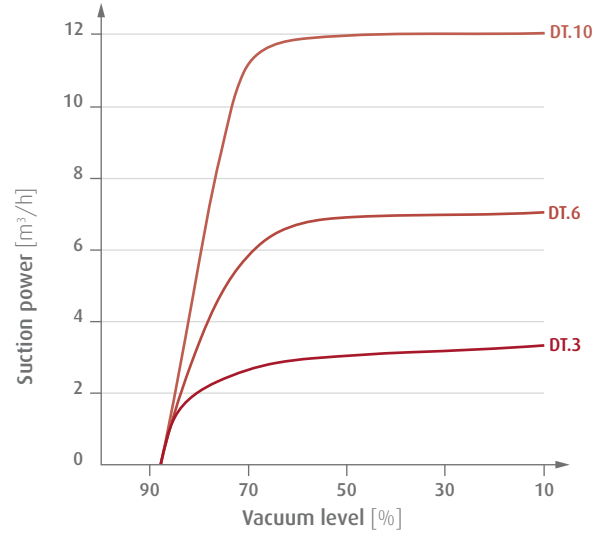



Rotary vane vacuum pumps - oil-free

Handling in dry areas



Product Description

- > High reliability and low maintenance costs owing to simple design
- > Universal application: Continuous operation at different vacuum levels
- > Cooling with powerful fan at the rear of the motor
- > Compact design and low weight

Ordering notes

- > Available in single-phase and three-phase designs (Index -1 or -3)
- > Included in scope of delivery:
 - Safety filter on suction side
 - Silencer on pressure side
- > Electric cables not included

Technical data

Item no.	DT.16B-1	DT.16B-3	DT.25B-1	DT.25B-3	DT.40B-1	DT.40B-3
Suction power at 50 Hz [m ³ /h]	16	16	25	25	40	40
Suction power at 60 Hz [m ³ /h]	19	19	29	29	46	46
Final vacuum [%]	88	88	88	88	88	88
Power supply at 50 (60) Hz [V]	220 - 240	Delta: 220-255 220-266 Star: 380-440 (380-460)	220 - 240	Delta: 220-255 220-266 Star: 380-440 (380-460)	220 - 240	Delta: 220-255 220-266 Star: 380-440 (380-460)
Current consumption at 50 (60) Hz [A]	5.6 (5)	Delta: 2,8-3 (3.8-3.2) Star: 1.6-1.7 (2.2-1.8)	5.8 (6.2)	Delta: 3.8-4.2 (4.4-4.2) Star: 2.2-2.4 (2.5-2.4)	9.8 (9)	Delta: 7 (7.1-7) Star: 4 (4.1-4.0)
Rated power at 50 Hz [kW]	0.66	0.55	0.75	0.75	1.5	1.5
Rated power at 60 Hz [kW]	0.72	0.66	0.9	0.9	1.8	1.8
Noise level at 50 Hz [dB(A)]	63	63	65	65	68	68
Noise level at 60 Hz [dB(A)]	65	65	67	67	70	70
Operating temperature at 50 Hz [°C]	55 - 60	55 - 60	65 - 70	65 - 70	75 - 80	75 - 80
Operating temperature at 60 Hz [°C]	60 - 65	60 - 65	70 - 75	70 - 75	80 - 85	80 - 85
Weight [kg]	29.5	27.5	29	28.5	40	37.5
Suitable accessories	Spare part kit KIT-DT.16B* Vacuum regulator 73.002 (p.640) Pre-filter FC 20F (p.624)		Spare part kit KIT-DT.25B* Vacuum regulator 73.003 (p.640) Pre-filter FC 25F (p.624)		Spare part kit KIT-DT.40B* Vacuum regulator 73.003 (p.640) Pre-filter FC 30F (p.624)	

Continued on the next page →



Vacuum generation | Oil-free vacuum pumps

Rotary vane vacuum pumps - oil-free

Dimensions

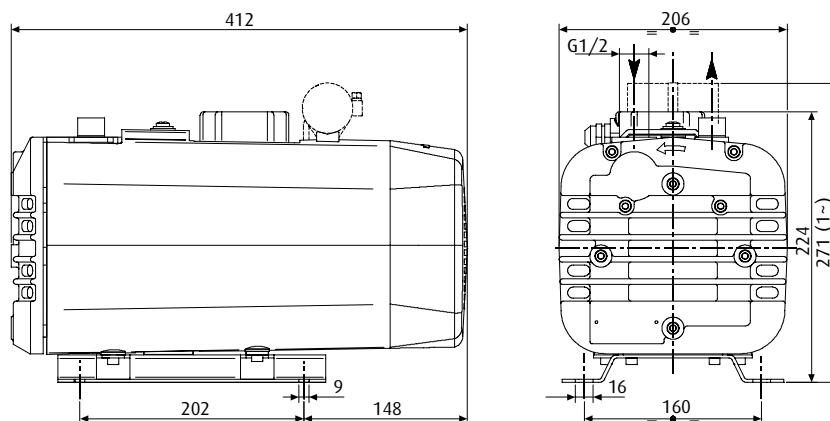

DT.16B-1 | DT.16B-3

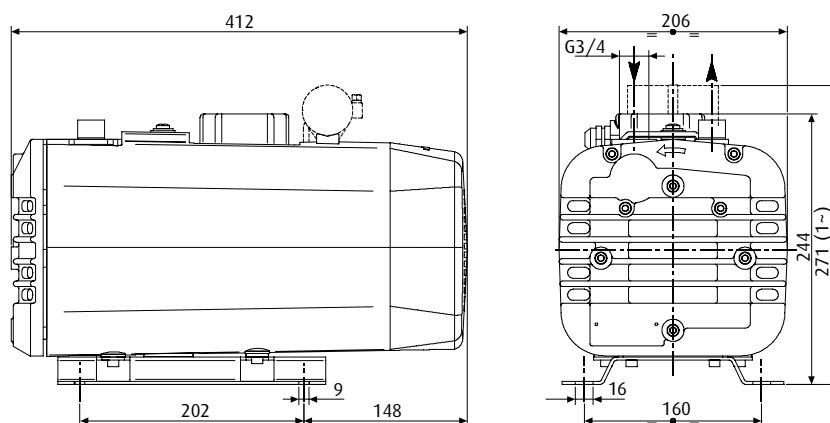

DT.25B-1 | DT.25B-3

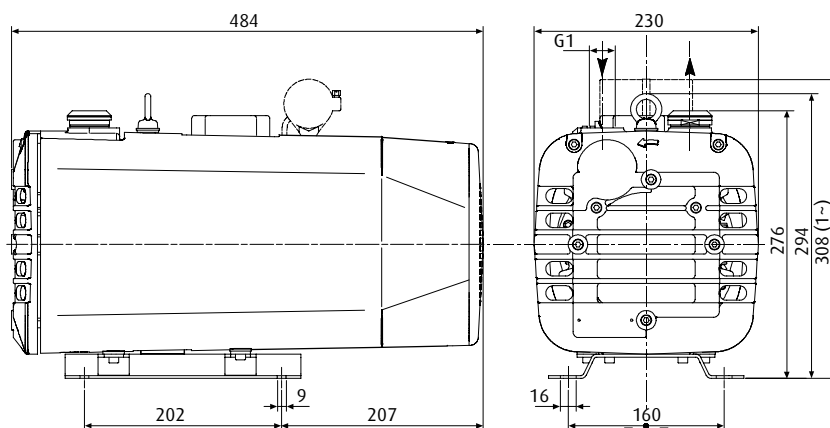

DT.40B-1 | DT.40B-3

* = 4 vanes, filter cartridge



Diagrams

> Suction power against vacuum level at 50 Hz

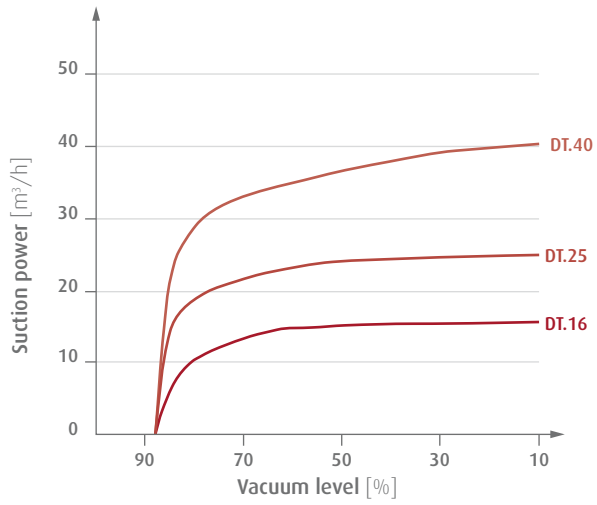

> Suction power against vacuum level at 60 Hz

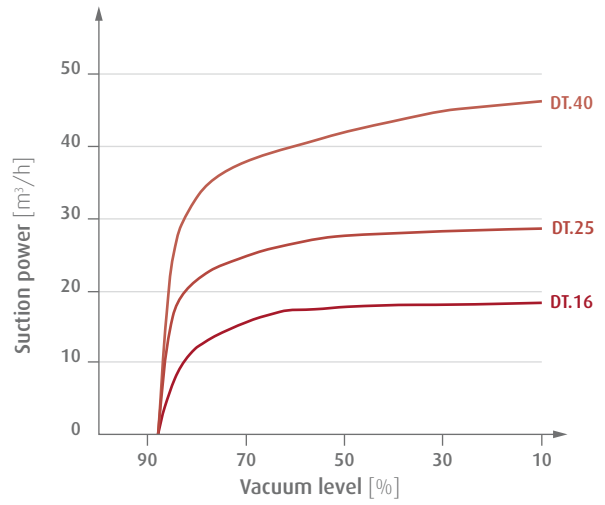



Rotary vane vacuum pumps - oil-free

Handling in dry areas



Product Description

- > High reliability and low maintenance costs owing to simple design
- > Universal application: Continuous operation at different vacuum levels
- > Compact design due to robust protective housing that also reduces the sound level
- > DT.60C-3: Universal motor according to IE class 2 with wide voltage spectrum for worldwide use

Ordering notes

- > Included in scope of delivery:
 - Safety filter on suction side
 - Silencer on pressure side
- > Electric cables not included

Technical data

Item no.	DT.60C-3	DT.80C-3
Suction power at 50 Hz [m ³ /h]	60	80
Suction power at 60 Hz [m ³ /h]	70	90
Final vacuum [%]	88	88
Power supply at 50 (60) Hz [V]	Delta: 230 (265) Star: 400 (460)	Delta: 230 (265) Star: 400 (460)
Current consumption at 50 (60) Hz [A]	Delta: 5.91 (5.6) Star: 3.4 (3.23)	Delta: 8.8 (9) Star: 5.1 (5.2)
Rated power at 50 Hz [kW]	1.5	2.2
Rated power at 60 Hz [kW]	1.8	2.7
Noise level at 50 Hz [dB(A)]	70	72
Noise level at 60 Hz [dB(A)]	72	74
Operating temperature at 50 Hz [°C]	70 - 73	72 - 78
Operating temperature at 60 Hz [°C]	72 - 75	75 - 80
Weight [kg]	66	71
Suitable accessories	Spare part kit KIT-DT.60C Silencer 72.003 (p.578) Pre-filter FC 30F (p.624)	Spare part kit KIT-DT.80C Silencer 72.003 (p.578) Pre-filter FC 35F (p.624)



Dimensions

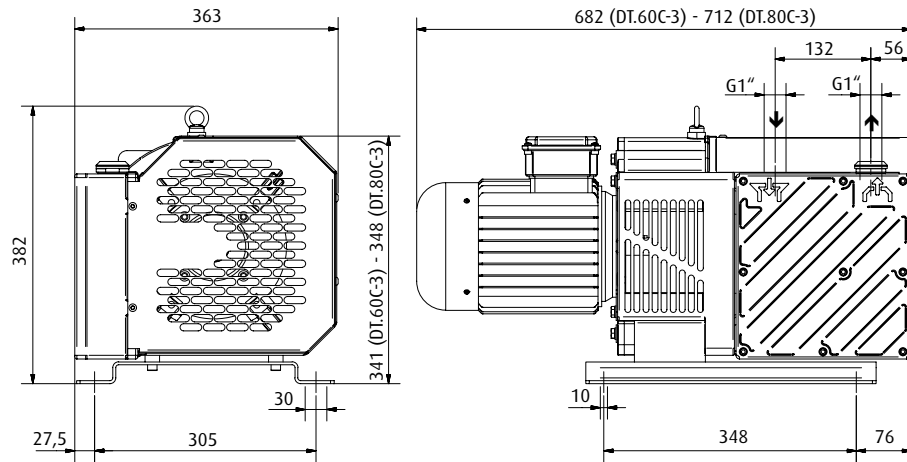

Diagrams

> Suction power against vacuum level at 50 Hz

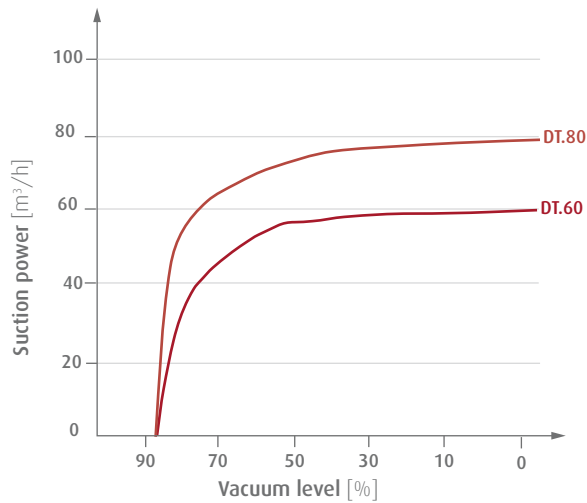

> Suction power against vacuum level at 60 Hz

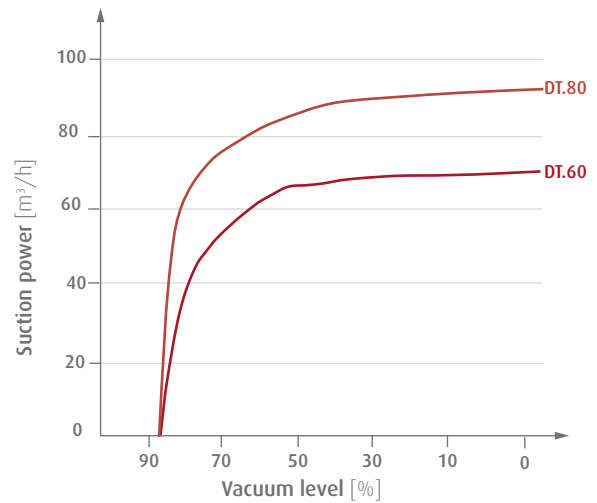



Rotary vane vacuum pumps - oil-free

Handling in dry areas



Product Description

- > High reliability and low maintenance costs owing to simple assembly
- > Universal application: Continuous operation at different vacuum levels
- > Compact design due to robust protective housing that also reduces the sound level
- > Universal motor according to IE class 2 with wide voltage spectrum for worldwide use

Ordering notes

- > Included in scope of delivery:
 - Safety filter on suction side
 - Silencer on pressure side
- > Electric cables not included

Technical data

Item no.	DT.100C-3	DT.140C-3
Suction power at 50 Hz [m ³ /h]	100	130
Suction power at 60 Hz [m ³ /h]	115	150
Final vacuum [%]	88	88
Power supply at 50 (60) Hz [V]	Delta: 230 (265) Star: 400 (460)	Delta: 230 (265) Star: 400 (460)
Current consumption at 50 (60) Hz [A]	Delta: 11.8 (11.4) Star: 6.8 (6.6)	Delta: 14.7 (13.5) Star: 8.5 (7.8)
Rated power at 50 Hz [kW]	3	4
Rated power at 60 Hz [kW]	3.6	4.8
Noise level at 50 Hz [dB(A)]	75	76
Noise level at 60 Hz [dB(A)]	77	78
Operating temperature at 50 Hz [°C]	78 - 82	80 - 83
Operating temperature at 60 Hz [°C]	80 - 85	85 - 90
Weight [kg]	87	95
Suitable accessories	Spare part kit KIT-DT.100C Pre-filter FC 40F (p.624)	Spare part kit KIT-DT.140C Pre-filter FC 50F (p.624)



Dimensions

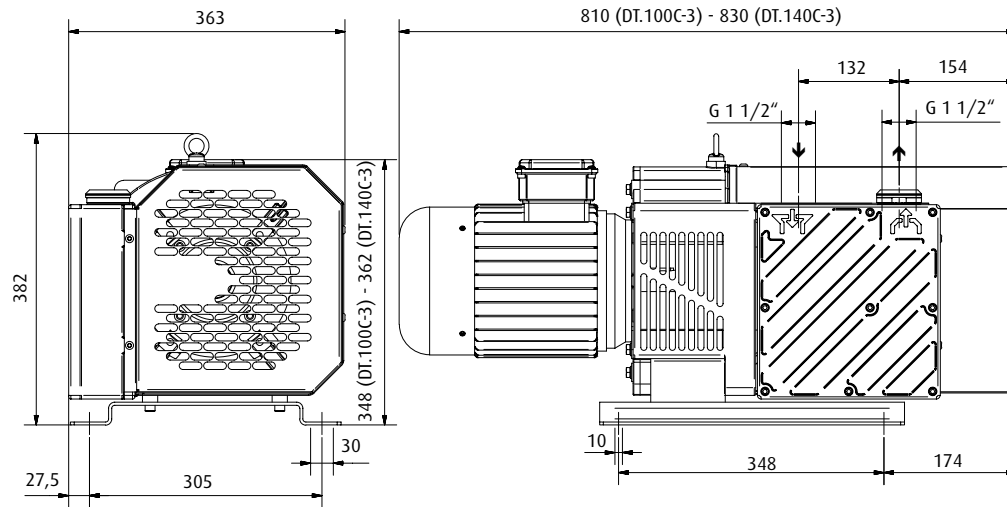

Diagrams

> Suction power against vacuum level at 50 Hz

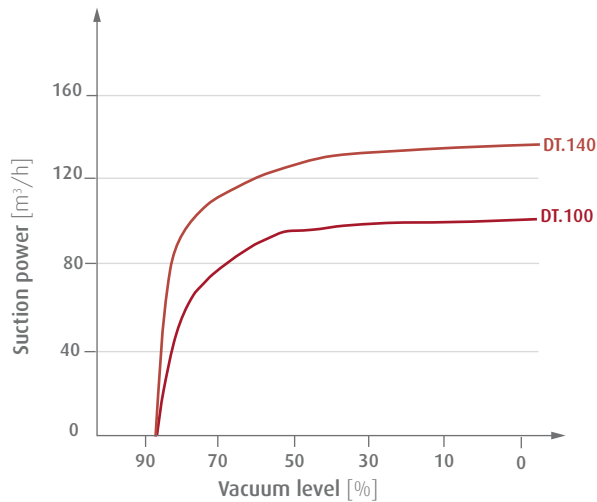

> Suction power against vacuum level at 60 Hz

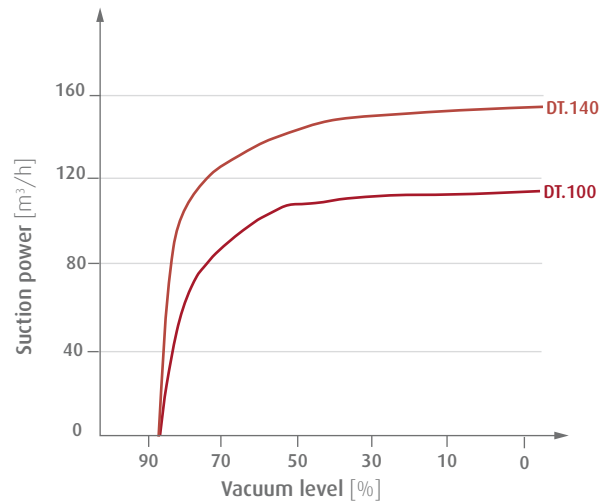



Piston pumps



Product Description

- > High volume flow and high vacuum level at low installation space
- > Can also be used as compressor
- > Low-vibration operation
- > Robust design
- > Long service life and maintenance-free operation due to permanently lubricated piston seals
- > Suitable for dry and moist air

Notes

- > A 3/2-way valve must be installed at the inlet in case of pressure-vacuum alternating operation

Technical data

Item no.	KE.1.9A-1
Suction power at 50 Hz [m ³ /h]	1.9
Suction power at 60 Hz [m ³ /h]	2.2
Final vacuum [%]	89
Power supply [V]	220 - 240
Rated power at 50 Hz [kW]	0.2
Noise level at 50 Hz [dB(A)]	50
Noise level at 60 Hz [dB(A)]	52
Operating temperature [°C]	40 - 45
Weight [kg]	7.1
Suitable Pre-filters	FB 5 (p.626)



Dimensions

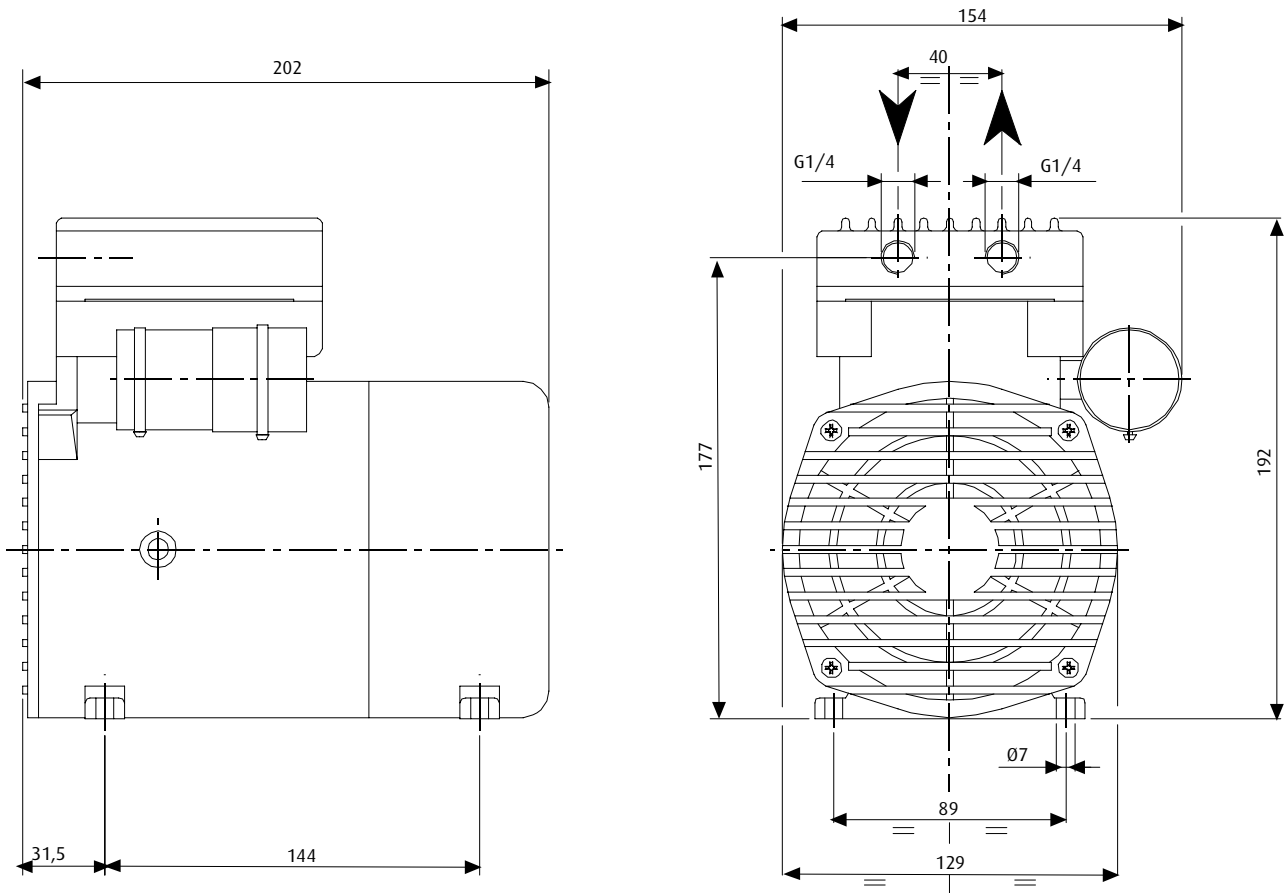

Diagrams

> Volume flow against pressure

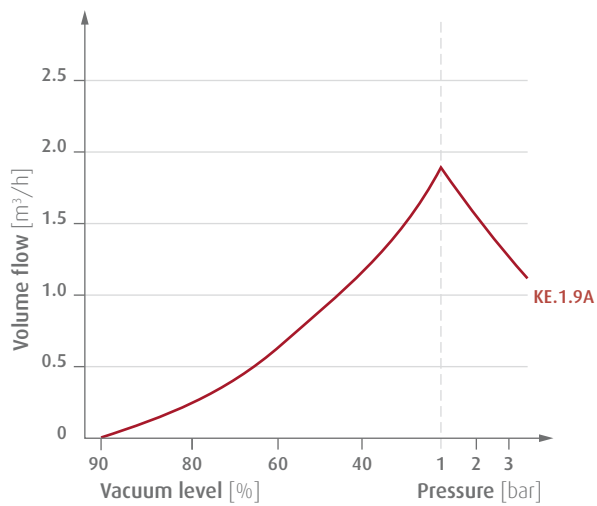



Rotary vane vacuum pumps - oil-lubricated



Product Description

- > Very high final vacuum level
- > Drives with multi-range voltages
- > Especially suited for the evacuation of small closed containers
- > Efficient damping and oil recovery system prevents oil mist and reduces sound level
- > Compact and lightweight design for low space requirements or installation on moving devices (sufficient ventilation needs to be ensured)
- > Pump is cooled via mounting fan
- > Horizontal mounting position

Notes

- > Continuous operation only under full load (min. 99.8 % vacuum), otherwise, risk of oil discharge, no gas ballast
- > For operation under moist conditions please consult FIPA

Ordering notes

- > Available in single-phase and three-phase designs (Index -1 to -3)
- > Included in scope of delivery: Condensate exhaust filter oil SW 40, thermal protection 130 °C (with single-phase motor)

Technical data

Item no.	DO.3B-1	DO.3B-3	DO.4B-1	DO.4B-3
Suction power at 50 Hz [m ³ /h]	3	3	4	4
Suction power at 60 Hz [m ³ /h]	3.2	3.2	4.4	4.4
Final vacuum [%]	99.8	99.8	99.8	99.8
Power supply +/- 5 % at 50 Hz [V]	220 - 240	Delta: 220-255 Star: 380-440	220 - 240	Delta: 220-255 Star: 380-440
Power supply +/- 5 % at 60 Hz [V]	220 - 240	Delta: 220-266 Star: 380-460	220 - 240	Delta: 220-266 Star: 380-460
Current consumption at 50 Hz [A]	1	Delta: 0.7-0.8 Star: 0.4-0.46	1	Delta: 0.7-0.8 Star: 0.4-0.46
Current consumption at 60 Hz [A]	1.1	Delta: 0.7 Star: 0.38-0.42	1.1	Delta: 0.7 Star: 0.38-0.42
Rated power at 50 (60) Hz [kW]	0.12 (0.15)	0.12 (0.14)	0.12 (0.15)	0.12 (0.14)
Noise level at 50 Hz [dB(A)]	56	56	57	57
Noise level at 60 Hz [dB(A)]	58	58	59	59
Operating temperature at 50 Hz [°C]	60 - 65	60 - 65	60 - 65	60 - 65
Operating temperature at 60 Hz [°C]	65 - 70	65 - 70	65 - 70	65 - 70
Weight [kg]	5.4	5.4	5.4	5.4
Suitable accessories	Spare part kit KIT-DO.3B/K*** Spare part kit KIT-DO.3B/G* Pre-filter FB 5 (p.626)		Spare part kit KIT-DO.4B/K*** Spare part kit KIT-DO.4B/G** Pre-filter FB 5 (p.626)	



Dimensions

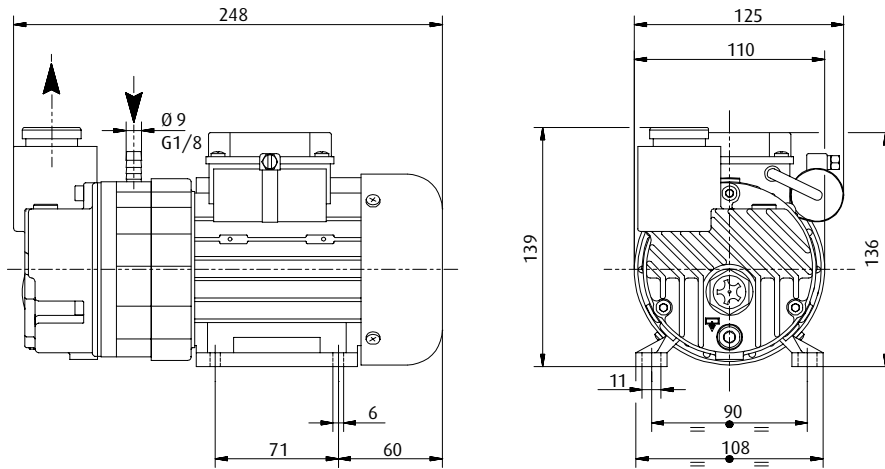

- * = 6 x vanes, FKM O-Rings, oil recirculation valve, oil mist separator, filter
- ** = 6 x vanes, FKM O-Rings, seal, oil recirculation valve, oil mist separator, filter
- *** = Oil mist separator, rubber washer, follower, 1 x filter cartridge, 1 x O-ring FKM

Diagrams

> Suction power against vacuum level at 50 Hz

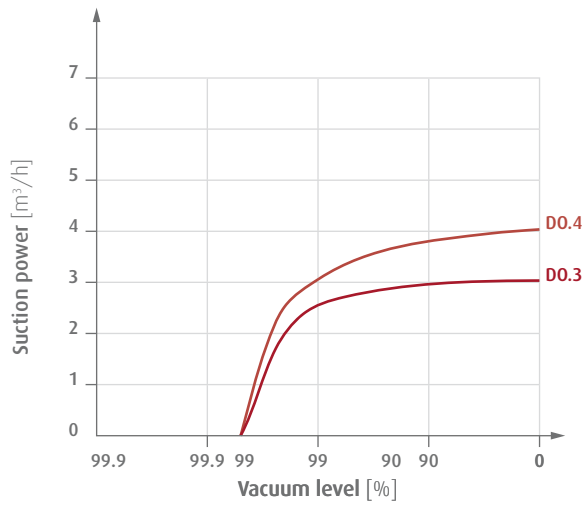

> Suction power against vacuum level at 60 Hz

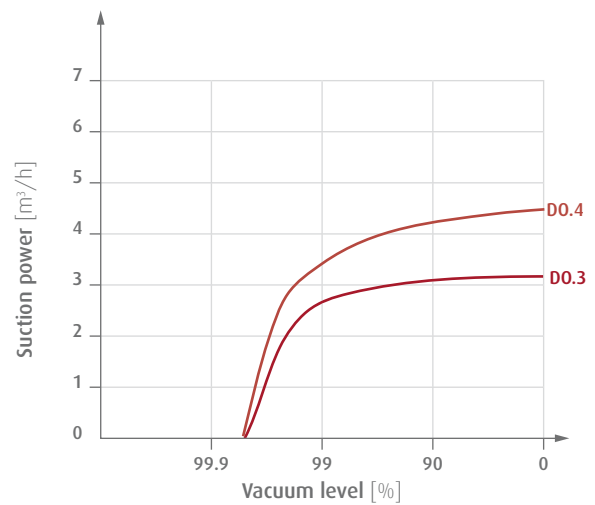



Rotary vane vacuum pumps - oil-lubricated

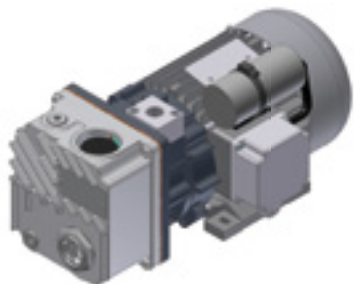

Product Description

- > Very high final vacuum level
- > Suitable for moist environments
- > Effective damping and recovery system prevents oil mist and reduces sound level
- > Innovative sealing system prevents oil recirculation at standstill under vacuum
- > Compact design and low weight
- > Horizontal mounting position

Notes

- > Designed for continuous operation under vacuum levels of 60 % to 99 %, integrated gas ballast, water vapor tolerance

Ordering notes

- > Available in single-phase and three-phase designs (Index -1 to -3)
- > Included in scope of delivery: Condensate exhaust filter, gas ballast, oil SW 60, oil non-return valve

Technical data

Item no.	DO.5B-1	DO.5B-3
Suction power at 50 Hz [m ³ /h]	5	5
Suction power at 60 Hz [m ³ /h]	6	6
Final vacuum [%]	99	99
Gas ballast	Yes	Yes
Max. inlet pressure for water vapour [mbar]	30	30
Steam capacity [l/h]	0.11	0.11
Check valve	Yes	Yes
Power supply at 50 (60) Hz [V]	220 - 240	Delta: 220-255 (220-266) Star: 380-440 (380-460)
Current consumption at 50 (60) Hz [A]	1.7 - 2.1	Delta: 1.8-2.3 (1.6-2.3) Star: 1-1.3 (0.9-1.3)
Rated power at 50 (60) Hz [kW]	0.25 (0.25)	0.37 (0.45)
Noise level at 50 (60) Hz [dB(A)]	58 (60)	58 (60)
Operating temperature [°C]	65 - 75	65 - 75
Weight [kg]	13	11.5
Suitable Spare-part-kits	KIT-DO.5B/G** KIT-DO.5B/K*	KIT-DO.5B/G** KIT-DO.5B/K*



Dimensions

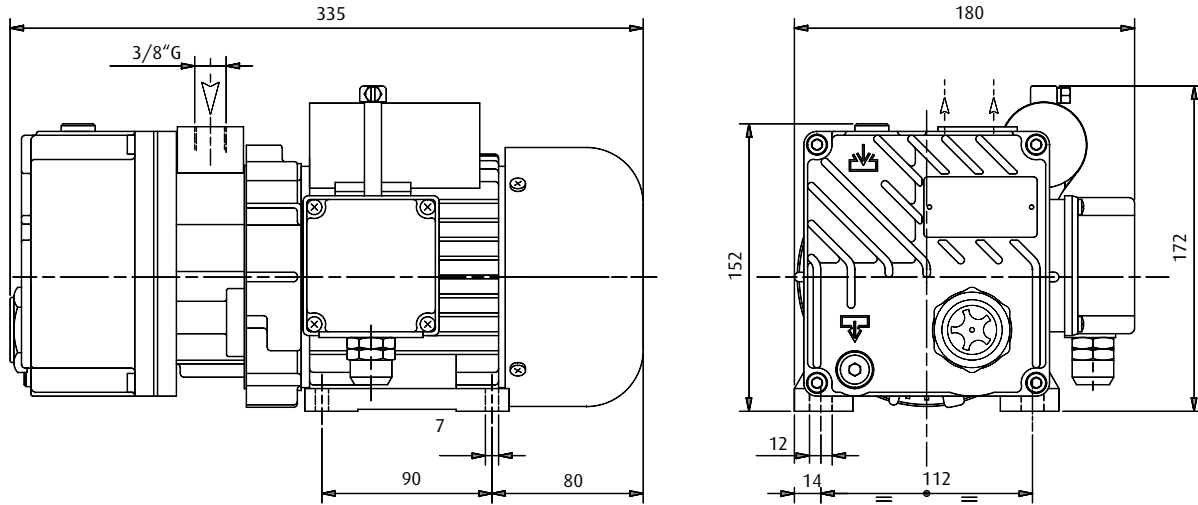

* = O-Ring 121 FKM, filter element ** = Shaft seal, 2 x O-Ring 3300 NBR, 3 x vanes, 2 x ejector, inlet shield, inlet rubber NBR, filter disk, NBR rubber for exhaust valve, 3 x copper washer, O-Ring 121 FKM, filter element, gasket, sintered filter G1/8

Diagrams

> Suction power against vacuum level at 50 Hz

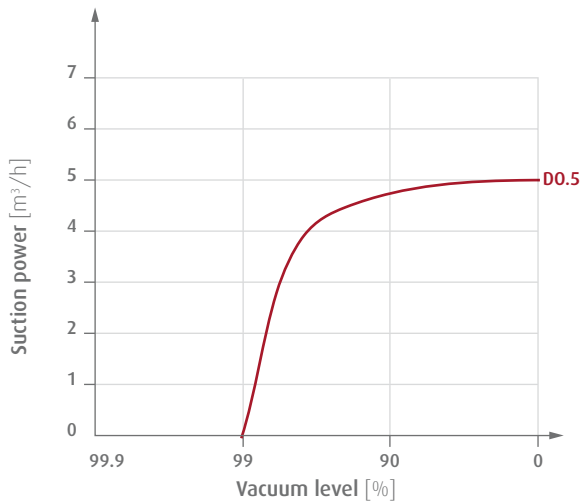

> Suction power against vacuum level at 60 Hz

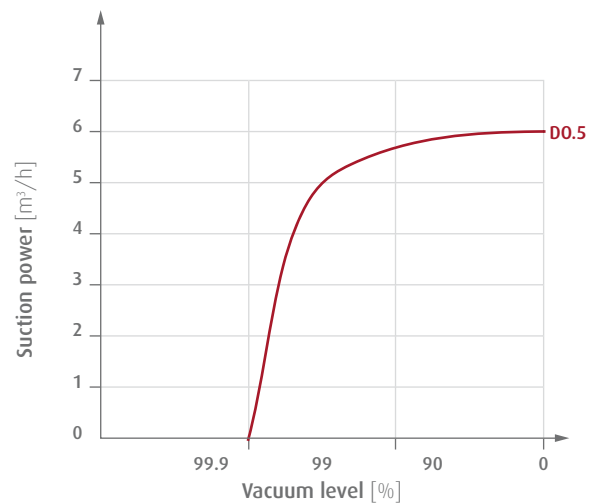



Rotary vane vacuum pumps - oil-lubricated



Product Description

- > Very high final vacuum level
- > Effective damping and recovery system prevents oil mist and reduces sound level
- > Innovative sealing system prevents oil recirculation at standstill under vacuum
- > Compact design and low weight
- > Horizontal mounting position

Notes

- > DO.8: Continuous operation only under full load (min. 99.8 % vacuum), otherwise, risk of oil discharge, no gas ballast
- > DO.8: For operation under moist conditions please consult FIPA
- > DO.12: Designed for continuous operation for vacuum levels between 60 and 99.9 %, gas ballast available, can tolerate water vapor

Ordering notes

- > Available in single-phase and three-phase designs (Index -1 or -3)
- > Included in scope of delivery: Condensate exhaust filter, gas ballast (with DO.12C-3), oil SW 40, oil non-return valve

Technical data

Item no.	DO.8B-1	DO.8B-3	DO.12C-1	DO.12C-3
Suction power at 50 Hz [m ³ /h]	8	8	12	12
Suction power at 60 Hz [m ³ /h]	9	9	14	14
Final vacuum [%]	99.8	99.8	99.8	99.8
Gas ballast	--	--	Yes	Yes
Max. inlet pressure for water vapour [mbar]	--	--	40	40
Steam capacity [l/h]	--	--	0.3	0.3
Check valve	Yes	Yes	Yes	Yes
Power supply at 50 (60) Hz [V]	220 - 240	Delta: 220-255 (220-266) Star: 380-440 (380-460)	220 - 240	Delta: 220-255 (220-266) Star: 380-440 (380-460)
Current consumption at 50 (60) Hz [A]	2.3 (2.5)	Delta: 1.4-1.5 (1.5-1.4) Star: 0.8-0.86 (0.86-0.8)	3-3.6 (3.3-3.1)	Delta: 1.4-1.5 (1.5-1.4) Star: 0.8-0.86 (0.86-0.8)
Rated power at 50 (60) Hz [kW]	0.37 (0.45)	0.25 (0.3)	0.45 (0.55)	0.37 (0.45)
Noise level at 50 (60) Hz [dB(A)]	58 (60)	58 (60)	60 (62)	60 (62)
Operating temperature [°C]	65 - 75	65 - 75	65 - 75	65 - 75
Weight [kg]	10	9	14	12.5
Suitable accessories	Spare part kit KIT-DO.8B/G** Spare part kit KIT-DO.8B/K* Pre-filter FB 10 (p.626)	Spare part kit KIT-DO.8B/G** Spare part kit KIT-DO.8B/K* Pre-filter FB 10 (p.626)	Spare part kit KIT-DO.12C/G**** Spare part kit KIT-DO.12C/K*** Pre-filter FB 20 (p.626)	Spare part kit KIT-DO.12C/G**** Spare part kit KIT-DO.12C/K*** Pre-filter FB 20 (p.626)



Dimensions

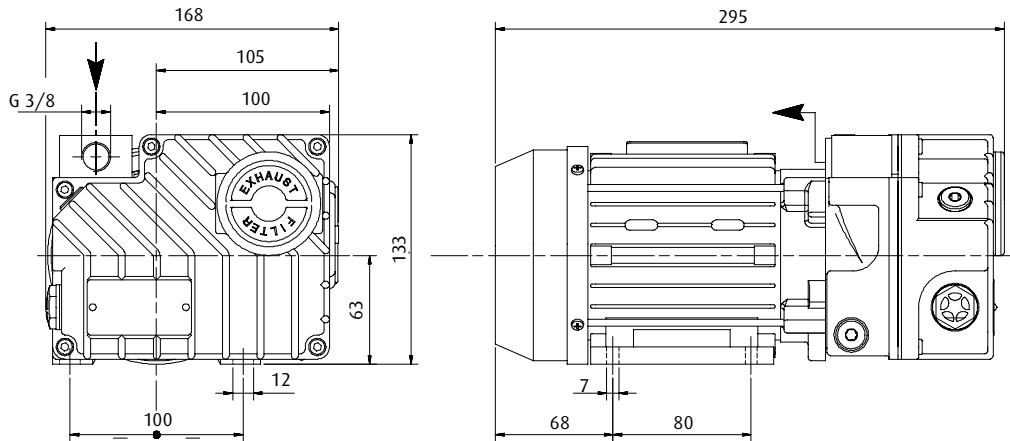

DO.8B-1 | DO.8B-3

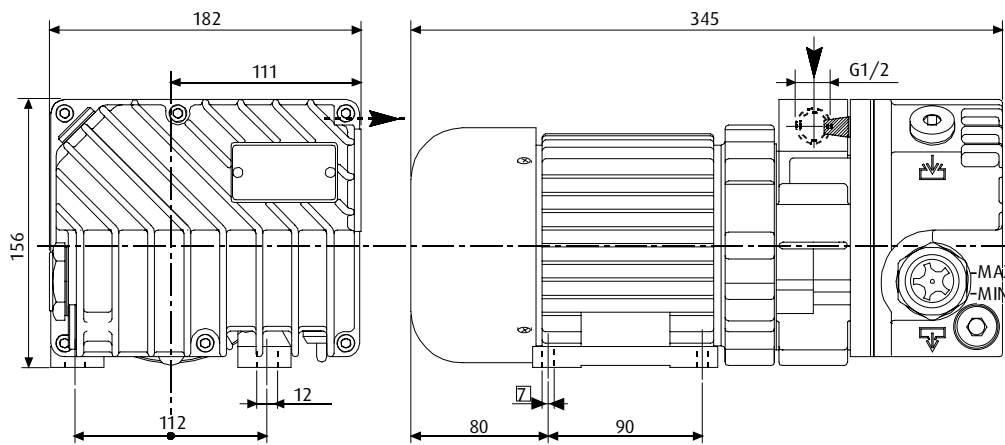

DO.12C-1 | DO.12C-3

* = FKM O-Rings, outlet filter ** = 3 vanes, FKM-O rings, seal, valve, inlet and outlet filter, oil recirculation valve
 *** = FKM O-rings, oil mist separator **** = 3 vanes, FKM o-rings, seal, filter, oil mist separator, spring

Diagrams

> Suction power against vacuum level at 50 Hz

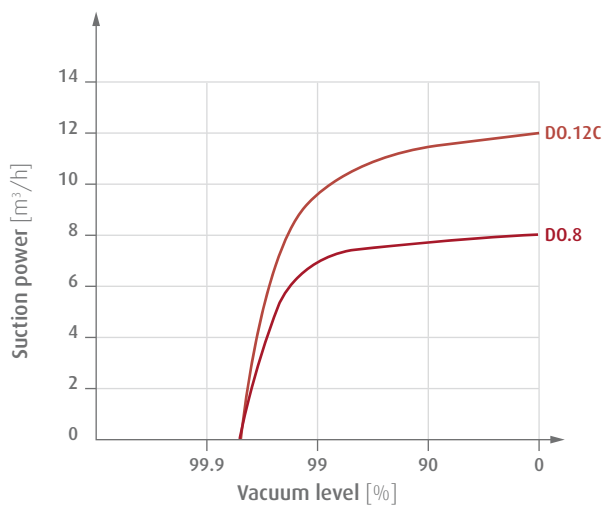

> Suction power against vacuum level at 60 Hz

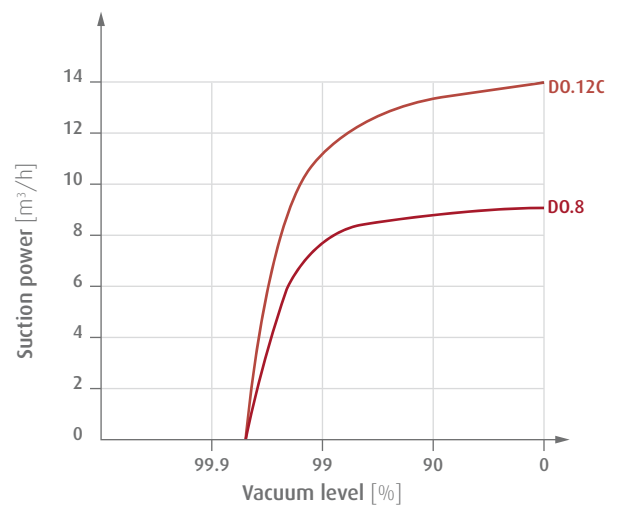



Rotary vane vacuum pumps - oil-lubricated



Product Description

- > Very high level of final vacuum
- > Suitable for moist environments
- > Effective damping and recovery system prevents oil mist and reduces sound level
- > Innovative sealing system prevents oil recirculation at standstill under vacuum
- > DO.20C-3 und DO.25C-3: Universal motor according to IE class 2 with wide voltage spectrum for worldwide use
- > Horizontal mounting position

Notes

- > DO.20: Designed for continuous operation for vacuum level between 60 % and 99.8 %, gas ballast available, can tolerate water vapor
- > DO.25: Designed for continuous operation for vacuum level between 60 % and 99.95 %, gas ballast available, can tolerate water vapor

Ordering notes

- > Available in single-phase and three-phase designs (Index -1 or -3)
- > Included in scope of delivery: Gas ballast, oil non-return valve, oil SW 40 (with DO.20), oil SW 60 (with DO.25)

Technical data

Item no.	DO.20C-1	DO.20C-3	DO.25C-1	DO.25C-3
Suction power at 50 Hz [m ³ /h]	20	20	25	25
Suction power at 60 Hz [m ³ /h]	24	24	29	29
Final vacuum [%]	99.8	99.8	99.95	99.95
Gas ballast	Yes	Yes	Yes	Yes
Max. inlet pressure for water vapour [mbar]	15	15	40	40
Steam capacity [l/h]	0.25	0.25	0.7	0.7
Check valve	Yes	Yes	Yes	Yes
Power supply at 50 (60) Hz [V]	220 - 240	Delta: 175-260 (200-300) Star: 300-450 (346-520)	220 - 240	Delta: 230 (265) Star: 400 (460)
Current consumption at 50 (60) Hz [A]	4-4.1 (5.7-5.6)	Delta: 3.4-3.3 (4.1-3.3) Star: 2.0-1.9 (2.4-1.9)	3 (3)	Delta: 3.0 (3.0) Star: 1.7 (1.7)
Rated power at 50 (60) Hz [kW]	0.75 (0.90)	0.75 (0.90)	0.75 (0.90)	0.75 (0.90)
Noise level at 50 (60) Hz [dB(A)]	64 (67)	64 (67)	62 (65)	62 (65)
Operating temperature [°C]	60 - 70	60 - 70	80 - 90	80 - 90
Weight [kg]	19	17	26	25
Suitable accessories	Spare part kit KIT-DO.20C/G** Spare part kit KIT-DO.20C/K* Pre-filter FB 20 (p.626)		Spare part kit KIT-DO.25C/G**** Spare part kit KIT-DO.25C/K*** Pre-filter FB 25 (p.626)	



Dimensions

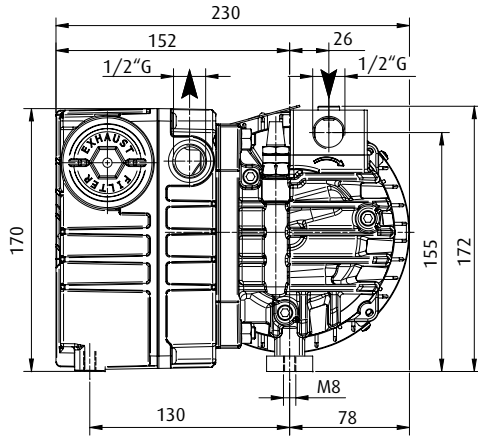

DO.20C-1 | DO.20C-3

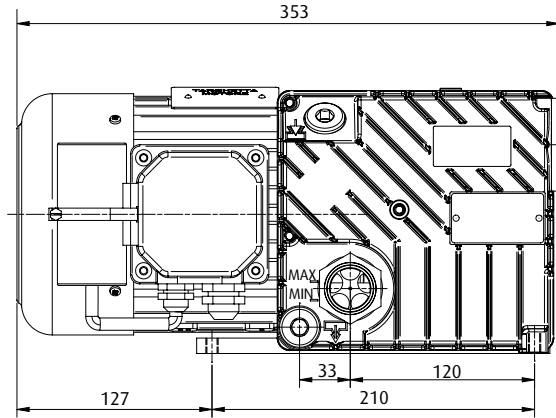

DO.25C-1 | DO.25C-3

* = FKM O-rings, oil mist separator ** = 3 x vanes, FKM O-rings, valve, filter, copper washer G1/8" *** = FKM and NBR O-rings, outlet filter
 **** = 2x FKM shaft seals, FKM O-rings, filter, valve, 3 vanes

Diagrams

> Suction power against vacuum level at 50 Hz

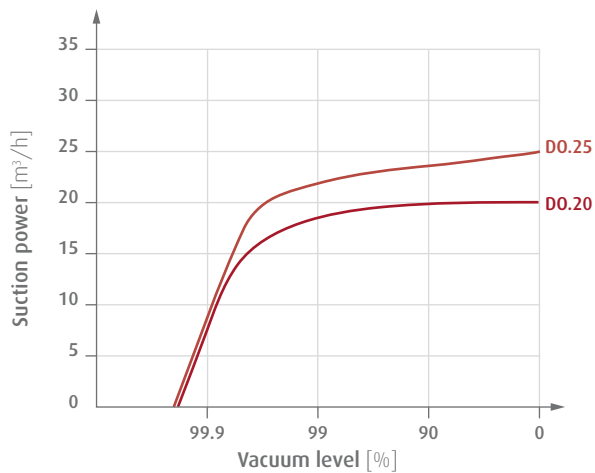

> Suction power against vacuum level at 60 Hz

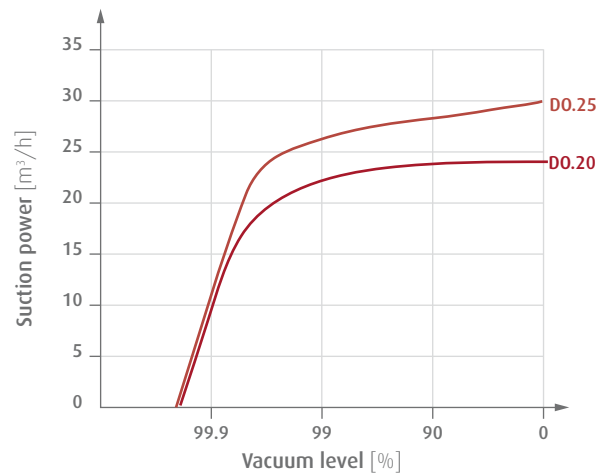



Rotary vane vacuum pumps - oil-lubricated



Product Description

- > Very high level of final vacuum
- > Suitable for moist environments
- > Effective damping and recovery system with by-pass and novel float valve guarantees oil-free exhaust air
- > Innovative sealing system prevents oil recirculation at standstill under vacuum
- > DO.40B-3 und DO.60B-3: Universal motor according to IE class 2 with wide voltage spectrum for worldwide use
- > Horizontal mounting position

Notes

- > Designed for continuous operation for vacuum level between 60 % to 99,95 %, gas ballast available, can tolerate water vapor

Ordering notes

- > Available in single-phase and three-phase designs (Index -1 or -3)
- > Included in scope of delivery: Condensate exhaust filter, gas ballast, oil SW 60, oil non-return valve

Technical data

Item no.	DO.40B-1	DO.40B-3	DO.60B-1	DO.60B-3
Suction power at 50 Hz [m ³ /h]	40	40	60	60
Suction power at 60 Hz [m ³ /h]	48	48	72	72
Final vacuum [%]	99.95	99.95	99.95	99.95
Gas ballast	Yes	Yes	Yes	Yes
Max. inlet pressure for water vapour [mbar]	30	30	40	40
Steam capacity [l/h]	0.9	0.9	1.8	1.8
Check valve	Yes	Yes	Yes	Yes
Power supply at 50 (60) Hz [V]	220 - 240	Delta: 230 (265) Star: 400 (460)	220 - 240	Delta: 230 (265) Star: 400 (460)
Current consumption at 50 (60) Hz [A]	4.1 (2.37)	Delta: 4.1 (4.3) Star: 2.37 (2,49)	5.76 (3.33)	Delta: 5.76 (5.72) Star: 3.33 (3.31)
Rated power at 50 (60) Hz [kW]	1.1 (1.35)	1.1 (1.35)	1.5 (1.8)	1.5 (1.8)
Noise level at 50 (60) Hz [dB(A)]	66 (68)	66 (68)	68 (70)	68 (70)
Operating temperature [°C]	70 - 80	70 - 80	75 - 85	75 - 85
Weight [kg]	49.5	43.5	50	44.5
Suitable accessories	Spare part kit KIT-DO.40B/G** Spare part kit KIT-DO.40B/k** Pre-filter FB 30 (p.626)		Spare part kit KIT-DO.60B/G** Spare part kit KIT-DO.60B/k** Pre-filter FB 30 (p.626)	



Dimensions

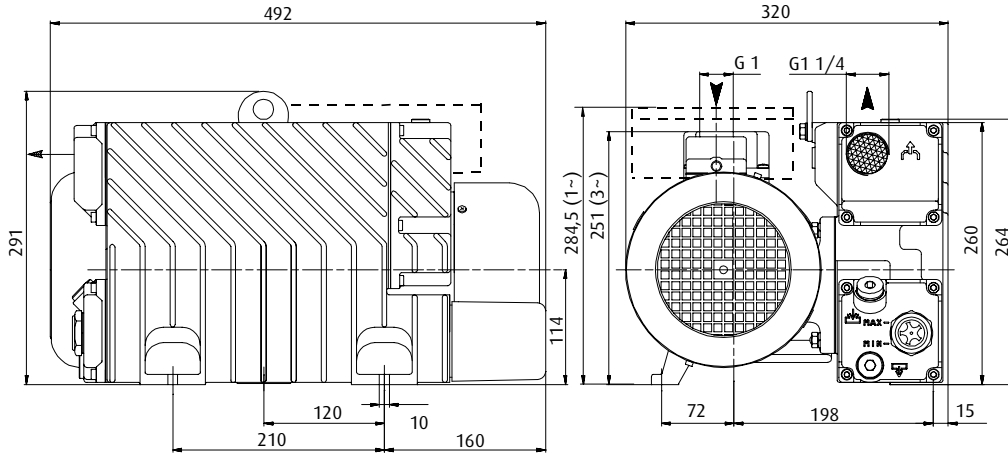

DO.40B-1 | DO.40B-3

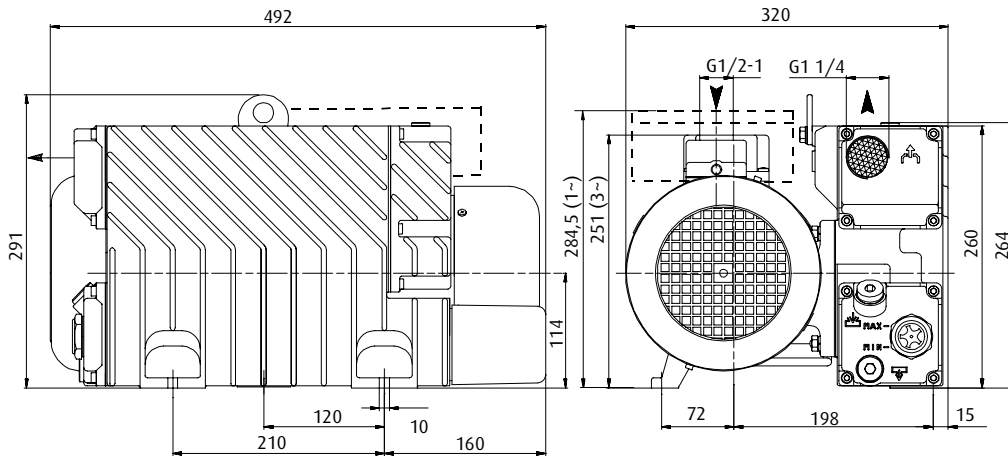

DO.60B-1 | DO.60B-3

* = Seal, Oil mist separator, Oil filter ** = 2 x FKM shaft seals, FKM O-rings, seals, filter, 3 x vanes

Diagrams

> Suction power against vacuum level at 50 Hz

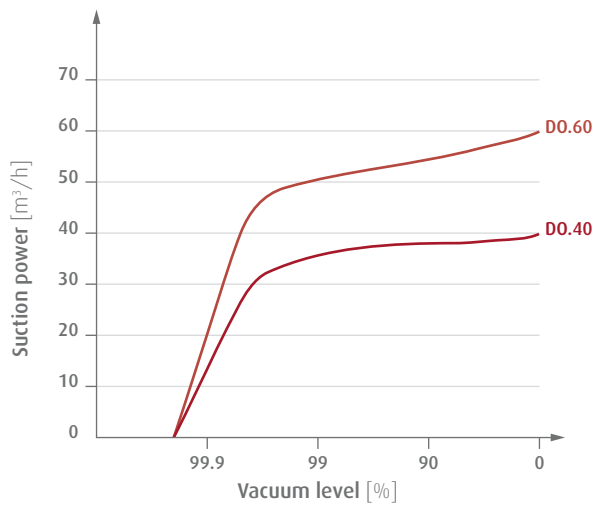

> Suction power against vacuum level at 60 Hz

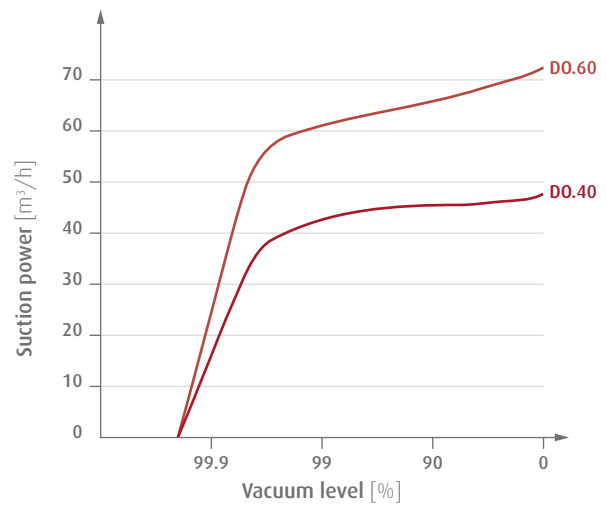



Rotary vane vacuum pumps - oil-lubricated



Product Description

- > Very high final vacuum
- > Suitable for moist environments
- > Effective damping and recovery system with by-pass and novel float valve guarantees oil-free exhaust air
- > Innovative sealing system prevents oil recirculation at standstill under vacuum
- > Elastic motor coupling effectively absorbs shocks
- > Universal motor according to IE class 2 with wide voltage spectrum for worldwide use
- > Horizontal mounting position

Notes

- > Designed for continuous operation for vacuum level between 60 % to 99.95 %, gas ballast available, can tolerate water vapor

Ordering notes

- > Scope of supply: Condensate exhaust filter, gas ballast, oil non-return valve, oil SW 100

Technical data

Item no.	DO.105C-3	DO.150C-3	DO.205C-3	DO.305C-3
Suction power at 50 Hz [m ³ /h]	105	150	205	305
Suction power at 60 Hz [m ³ /h]	125	180	245	365
Final vacuum [%]	99.95	99.95	99.95	99.95
Gas ballast	Yes	Yes	Yes	Yes
Max. inlet pressure for water vapour [mbar]	30	25	25	25
Steam capacity [l/h]	2.2	2.5	3.5	5
Check valve	Yes	Yes	Yes	Yes
Power supply at 50 (60) Hz [V]	Delta: 230 (265) Star: 400 (460)	Delta: 230 (265) Star: 400 (460)	Delta: 230 (265) Star: 400 (460)	Delta: 230 (265) Star: 400 (460)
Current consumption at 50 (60) Hz [A]	Delta: 8.8 (9.0) Star: 5.1 (5.2)	Delta: 8.8 (9.0) Star: 5.1 (5.2)	Delta: 20 (20.3) Star: 11.6 (11.7)	Delta: 27.7 (26.8) Star: 16 (15.5)
Rated power at 50 (60) Hz [kW]	2.2 (2.7)	3 (3.6)	4 (4.8)	7.5 (8.6)
Noise level at 50 (60) Hz [dB(A)]	68 (70)	70 (72)	72 (74)	74 (76)
Operating temperature [°C]	75 - 85	75 - 85	70 - 80	75 - 85
Weight [kg]	70	82	154	164
Suitable accessories	Spare part kit KIT-DO.105C/K*** Spare part kit KIT-DO.105C/G* Pre-filter FB 40 (p.626)	Spare part kit KIT-DO.150C/K*** Spare part kit KIT-DO.150C/G* Pre-filter FB 50 (p.626) Pre-filter FB 60 (p.626)	Spare part kit KIT-DO.205C/K*** Spare part kit KIT-DO.205C/G** Pre-filter FB 50 (p.626) Pre-filter FB 60 (p.626)	Spare part kit KIT-DO.305C/K*** Spare part kit KIT-DO.305C/G** Pre-filter FB 60 (p.626)



Dimensions

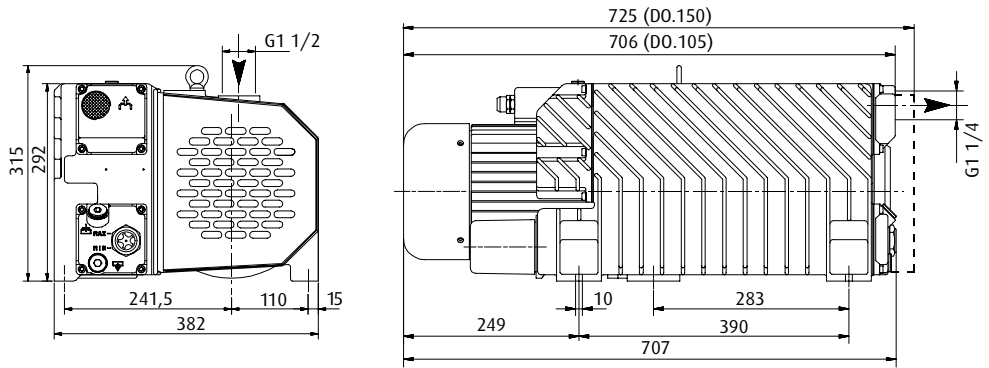

DO.105C-3 | DO.150C-3

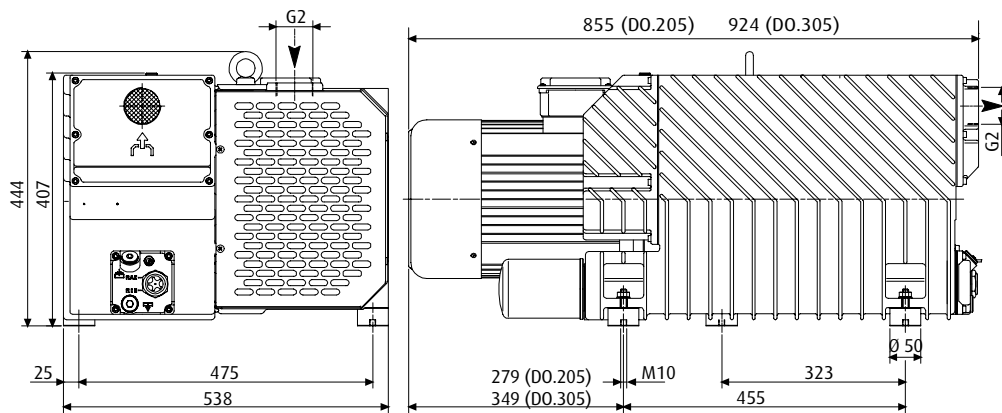

DO.205C-3 | DO.305C-3

* = Rubber link, seals, 3 vanes, FKM shaft seal, FKM O-rings, oil filter with bypass

** = Rubber link, FKM and NBR O-rings, 3 x vanes, oil recirculation pipe, gas ballast pipe, filters, oil inspection glass

*** = Oil filter with bypass valve, exhaust filter, gasket

Diagrams

> Suction power against vacuum level at 50 Hz

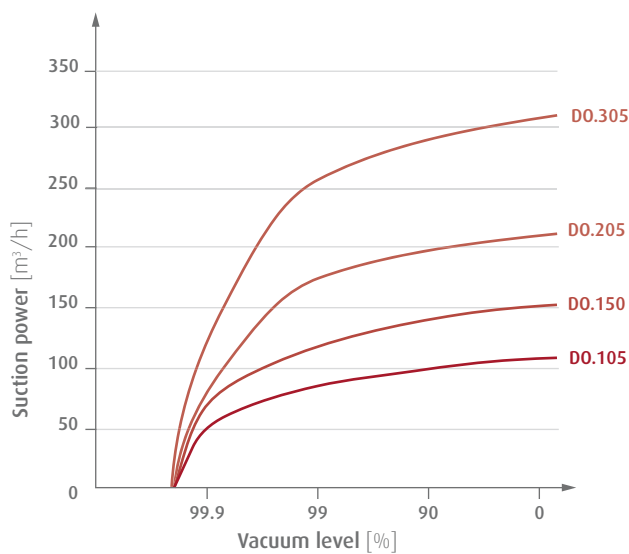

> Suction power against vacuum level at 60 Hz

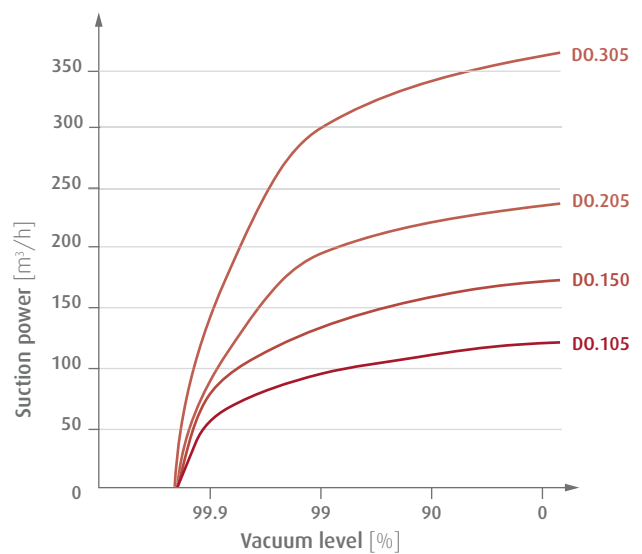



Portable vacuum units with condensate discharge for liquids

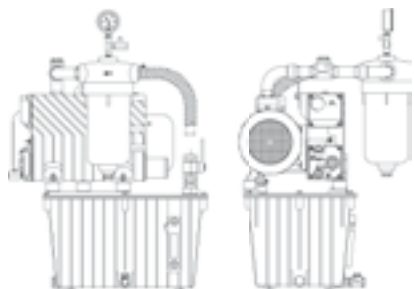

Product Description

- > Portable system for vacuum supply for i.e. suction cups or fixing tools
- > Specially developed for the extraction of non-aggressive liquids such as e.g. cooling lubricants in the glass, marble and CNC machine markets

Ordering notes

Included in scope of delivery:

- > Vacuum tank
- > Oil-lubricated vacuum pump
- > Vacuum gauge
- > Condensate trap filter
- > Non-return valve at the tank inlet to separate the pump for maintenance
- > Float level control for automatic discharge of the collected liquid
- > Condensate discharge
- > Non-return valve and gas ballast for trapping and discharge the condensed water from the oil at standstill

Technical data

Item no.	Safety tank volume of vacuum tank [l]	Suction power at 50 Hz [m ³ /h]	Suction power at 60 Hz [m ³ /h]	Final vacuum [%]	Rated power at 50 Hz [kW]	Rated power at 60 Hz [kW]	Weight [kg]
VZ.DO.4B-1/8L	8	4	4.4	99.8	0.12	0.15	11
VZ.DO.5B-1/25L	25	5	6	99	0.25	0.25	31
VZ.DO.25C-3/25L	25	25	29	99.5	0.75	0.9	55
VZ.DO.40C-3/25L	25	40	48	99.5	1.1	1.35	71
VZ.DO.60C-3/25L	25	60	75	99.5	1.5	1.8	72



Dimensions

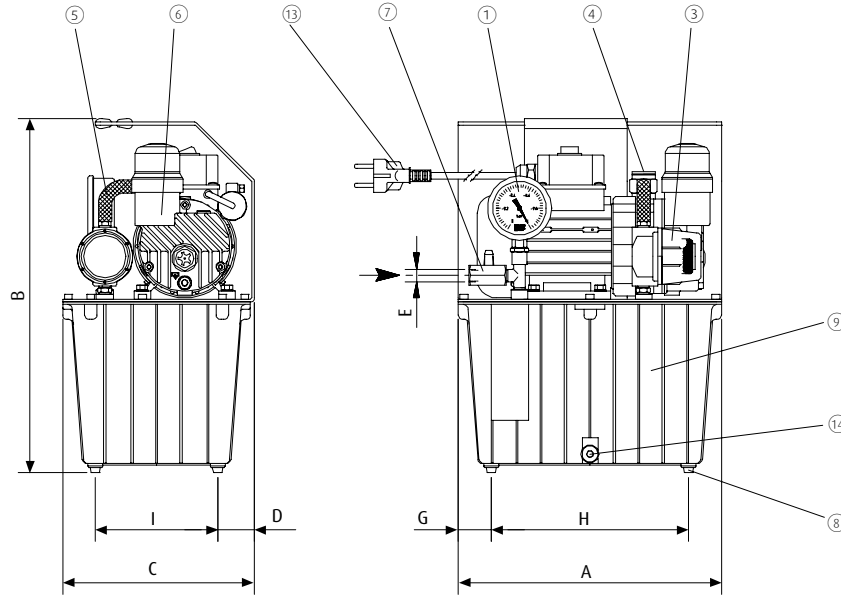

VZ.DO.4B-1/8L

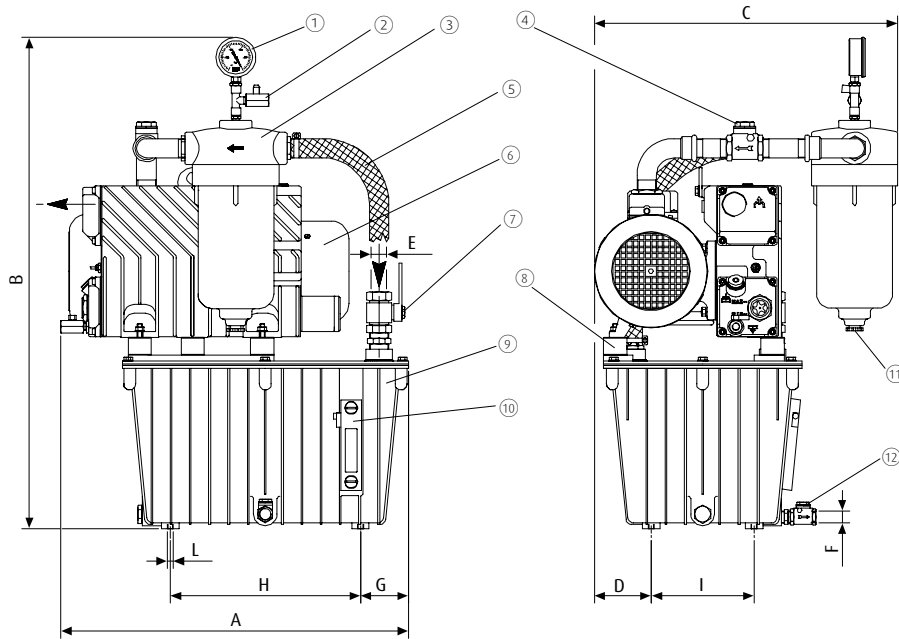

VZ.DO.5B-1/25L | VZ.DO.25C-3/25L | VZ.DO.40C-3/25L | VZ.DO.60C-3/25L

- ① = Vacuum gauge ② = Blow-off valve ③ = Filter ④ = Check valve ⑤ = Reinforced PVC tubing ⑥ = Vacuum pump
- ⑦ = Connection valve of the system ⑧ = Vibration absorber ⑨ = Vacuum tank ⑩ = Liquid display ⑪ = Condensate blow-off valve
- ⑫ = Automatic blow-off valve ⑬ = Power cable ⑭ = Blow-off vacuum tank

Item no.	A [mm]	B [mm]	C [mm]	D [mm]	E	F	G [mm]	H [mm]	I [mm]	L
VZ.DO.4B-1/8L	280	371	204	39	G1/4	--	35	210	130	--
VZ.DO.5B-1/25L	490	712	362	82	G1	G1/2	82	326	176	4xM10
VZ.DO.25C-3/25L	526	703	437	82	G1	G1/2	82	326	176	4xM10
VZ.DO.40C-3/25L	595	831	520	98	G1	G1/2	82	326	176	4xM10
VZ.DO.60C-3/25L	595	841	520	98	G1	G1/2	82	326	176	4xM10



Vacuum units with one pump

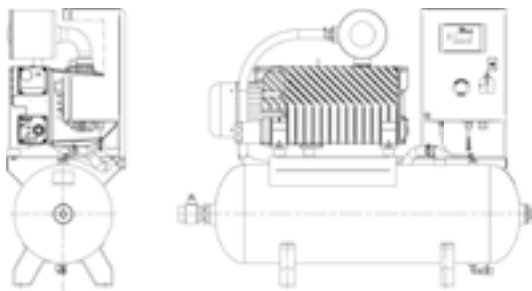

Product Description

- > Centralised vacuum supply with horizontal buffer tank

Ordering notes

Included in scope of delivery:

- > Oil-lubricated rotary vane pump with integrated oil mist separator at the outlet
- > Horizontal vacuum tank with condensate discharge valve
- > Particle filter to protect the pump
- > Non-return valve to maintain the vacuum when the pump is at standstill
- > Control panel (400 VAC, 50/60 Hz) with current protection, pressure sensor and PLC for manual and automatic operation
- > Switching cabinet IP 55
- > On request: Optional filter between the non-return valve and the vacuum system

Technical data

Item no.	Safety tank volume of vacuum tank [l]	Suction power at 50 Hz [m ³ /h]	Suction power at 60 Hz [m ³ /h]	Final vacuum [%]	Rated power at 50 Hz [kW]	Rated power at 60 Hz [kW]	Weight [kg]
VZ.1xDO.25C-3/100L	100	25	29	99	0.75	0.9	88
VZ.1xDO.25C-3/300L	300	25	29	99	0.75	0.9	133
VZ.1xDO.40B-3/100L	100	40	48	99	1.1	1.35	109
VZ.1xDO.40B-3/300L	300	40	48	99	1.1	1.35	154
VZ.1xDO.40B-3/500L	500	40	48	99	1.1	1.35	214
VZ.1xDO.60B-3/100L	100	60	75	99	1.5	1.8	112
VZ.1xDO.60B-3/300L	300	60	75	99	1.5	1.8	157
VZ.1xDO.60B-3/500L	500	60	75	99	1.5	1.8	217
VZ.1xDO.105C-3/100L	100	105	125	99	2.2	2.7	137
VZ.1xDO.105C-3/300L	300	105	125	99	2.2	2.7	182
VZ.1xDO.105C-3/500L	500	105	125	99	2.2	2.7	242
VZ.1xDO.205C-3/500L	500	205	245	99	4	4.8	400
VZ.1xDO.305C-3/500L	500	305	365	99	5.5	6.5	410



Dimensions

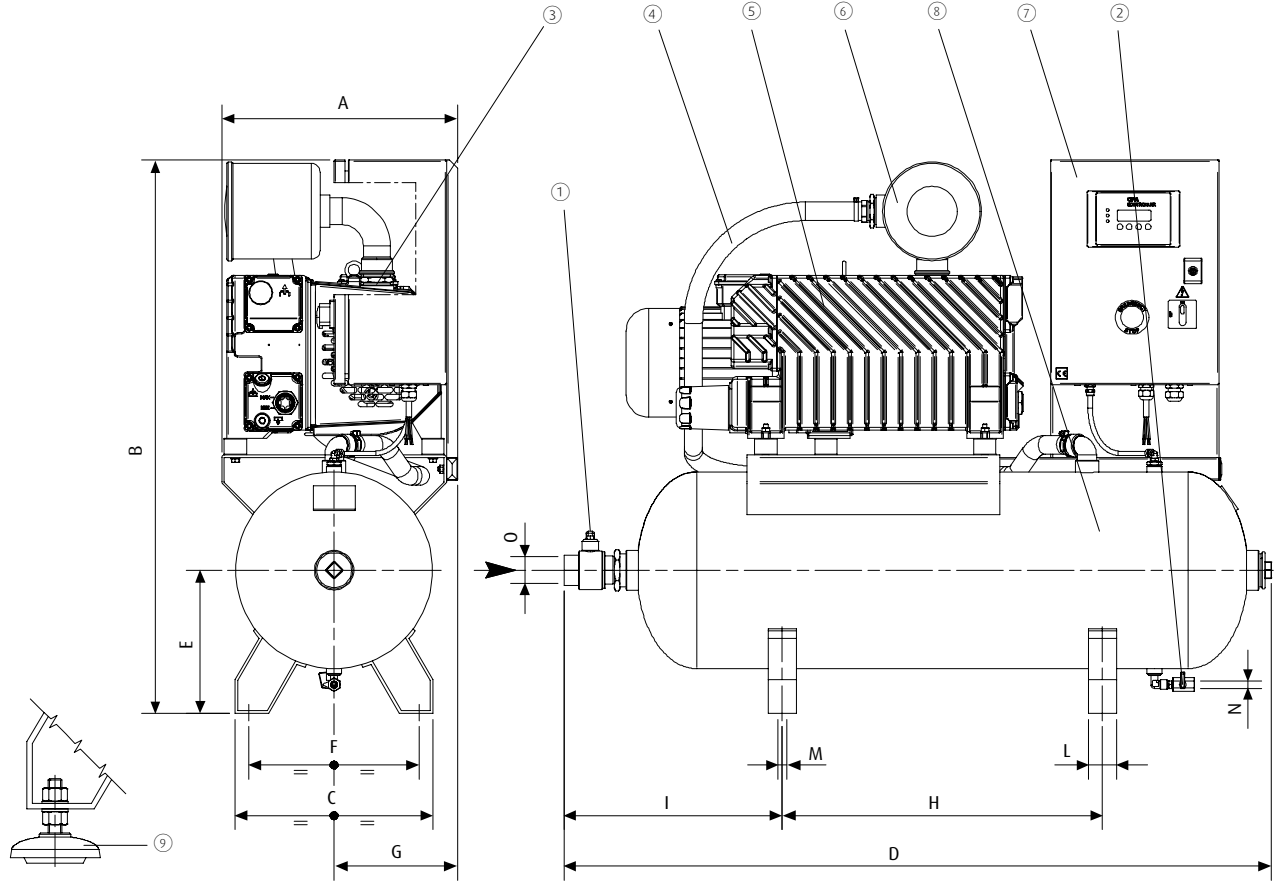

① = Connection valve of the system ② = Condensate blow-off valve ③ = Check valve ④ = Reinforced PVC tubing ⑤ = Vacuum pump
 ⑥ = Filter ⑦ = Switchbox ⑧ = Vacuum tank ⑨ = Vibration absorber (on request)

Item no.	A [mm]	B [mm]	C [mm]	D [mm]	E [mm]	F [mm]	G [mm]	H [mm]	I [mm]	L [mm]	M	N	O
VZ.1xDO.25C-3/100L	488	985	353	1,235	255	295	220	570	364	50	4xØ13	G1/4	G1
VZ.1xDO.25C-3/300L	493	1,220	512	1,626	330	454	245	895	410	50	4xØ13	G1/4	G1 1/2
VZ.1xDO.40B-3/100L	493	985	353	1,260	255	295	236	570	389	50	4xØ13	G1/4	G1 1/2
VZ.1xDO.40B-3/300L	502	1,220	512	1,620	330	454	245	895	404	50	4xØ13	G1/4	G1 1/2
VZ.1xDO.40B-3/500L	624	1,329	540	2,020	385	480	300	1,020	541	60	4xØ13	G1/4	G2
VZ.1xDO.60B-3/100L	493	985	353	1,260	255	295	236	570	389	50	4xØ13	G1/4	G1 1/2
VZ.1xDO.60B-3/300L	502	1,220	512	1,620	330	454	245	895	404	50	4xØ13	G1/4	G1 1/2
VZ.1xDO.60B-3/500L	624	1,329	540	2,025	385	480	300	1,020	541	60	4xØ13	G1/4	G2
VZ.1xDO.105C-3/100L	420	985	353	1,260	255	295	220	570	389	50	4xØ13	G1/4	G1 1/2
VZ.1xDO.105C-3/300L	450	1,220	512	1,620	330	454	245	895	404	50	4xØ13	G1/4	G1 1/2
VZ.1xDO.105C-3/500L	707	1,329	540	2,025	385	480	396	1,020	548	60	4xØ13	G1/4	G1 1/2
VZ.1xDO.205C-3/500L	600	1,412	540	2,020	385	480	300	1,020	543	60	4xØ13	G1/4	G2
VZ.1xDO.305C-3/500L	600	1,412	540	2,020	385	480	300	1,020	543	60	4xØ13	G1/4	G2



Vacuum units with two pumps

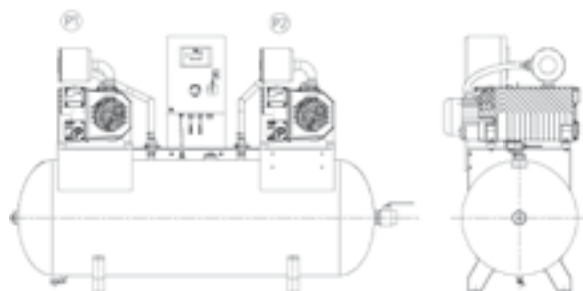

Product Description

- > Centralised vacuum supply with two pumps and horizontal buffer tank
- > Redundant system that enables maintenance work to be done during operation

Ordering notes

Included in scope of delivery:

- > Two oil-lubricated rotary vane pumps with integrated oil mist separator at the outlet
- > Integrated non-return valve at the suction inlet to maintain the vacuum at standstill
- > Horizontal vacuum tank with condensate discharge valve
- > Two manual valves at the tank inlet to separate the pump from the system for maintenance
- > Particle filter to protect the pump
- > Control panel (400 VAC, 50/60 Hz) with current protection, pressure sensor and PLC for manual and automatic operation
- > Switching cabinet IP 55
- > On request: Optional filter between non-return valve and load end

Technical data

Item no.	Safety tank volume of vacuum tank [l]	Suction power at 50 Hz [m ³ /h]	Suction power at 60 Hz [m ³ /h]	Final vacuum [%]	Rated power at 50 Hz [kW]	Rated power at 60 Hz [kW]	Weight [kg]
VZ.2xDO.25C-3/300L	300	50	58	99	2x0.75	2x0.90	165
VZ.2xDO.40B-3/300L	300	80	96	99	2x1.1	2x1.35	195
VZ.2xDO.40B-3/500L	500	80	96	99	2x1.1	2x1.35	280
VZ.2xDO.60B-3/300L	300	120	150	99	2x1.5	2x1.8	200
VZ.2xDO.60B-3/500L	500	120	150	99	2x1.5	2x1.8	285
VZ.2xDO.105C-3/500L	500	210	250	99	2x2.2	2x2.7	340
VZ.2xDO.205C-3/1000L	1,000	410	490	99	2x4	2x4.8	580
VZ.2xDO.305C-3/1000L	1,000	610	730	99	2x7.5	2x9	600



Dimensions

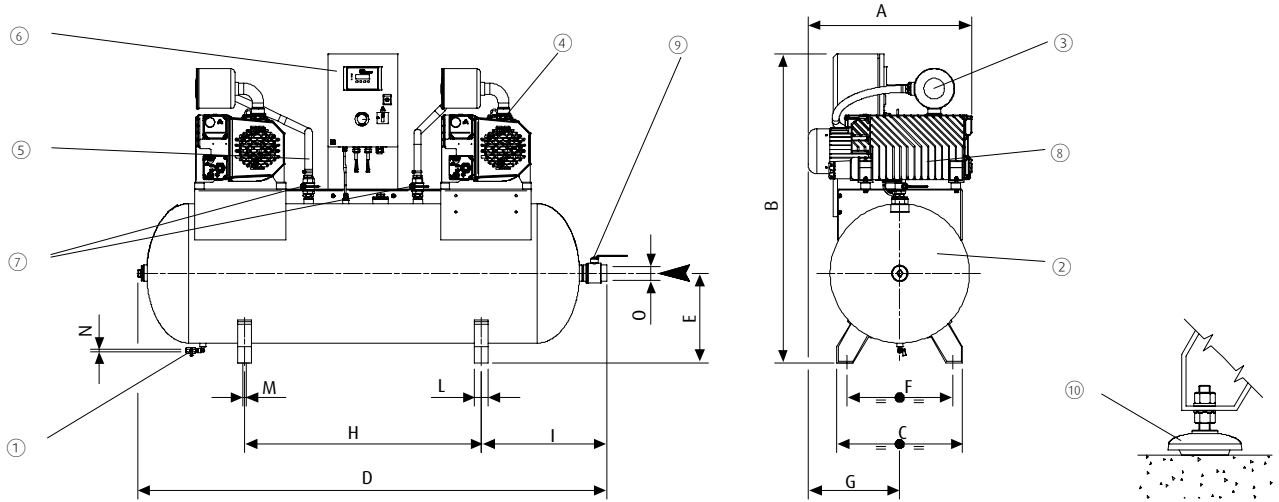

VZ.2xDO.25C-3/300L | VZ.2xDO.40B-3/300L | VZ.2xDO.40B-3/500L | VZ.2xDO.60B-3/300L | VZ.2xDO.60B-3/500L | VZ.2xDO.105C-3/500L

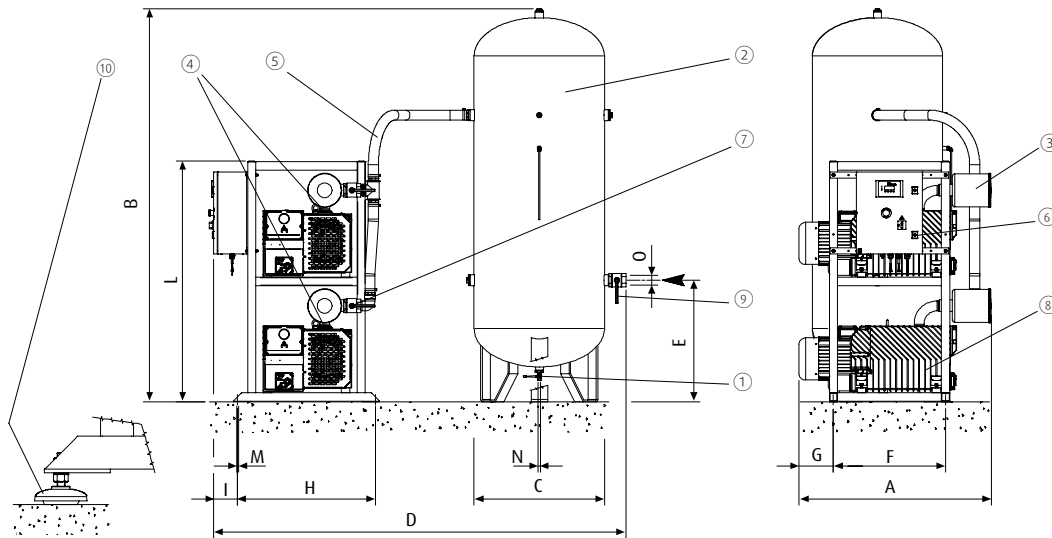

VZ.2xDO.205C-3/1000L | VZ.2xDO.305C-3/1000L

- ① = Condensate blow-off valve
- ② = Vacuum tank
- ③ = Filter
- ④ = Check valve
- ⑤ = Reinforced PVC tubing
- ⑥ = Switchbox
- ⑦ = Vacuum pump blocking valve
- ⑧ = Vacuum pump
- ⑨ = Connection valve of the system
- ⑩ = Vibration absorber

Item no.	A [mm]	B [mm]	C [mm]	D [mm]	E [mm]	F [mm]	G [mm]	H [mm]	I [mm]	L [mm]	M	N	O
VZ.2xDO.25C-3/300L	498	1,322	512	1,626	330	454	245	895	410	50	4xØ13	G1/4	G1 1/2
VZ.2xDO.40B-3/300L	502	1,320	512	1,620	330	454	245	895	404	50	4xØ13	G1/4	G1 1/2
VZ.2xDO.40B-3/500L	624	1,329	540	2,020	385	480	300	1,020	543	60	4xØ13	G1/4	G2
VZ.2xDO.60B-3/300L	502	1,320	512	1,620	330	454	245	895	404	50	4xØ13	G1/4	G1 1/2
VZ.2xDO.60B-3/500L	624	1,429	540	2,020	385	480	300	1,020	541	60	4xØ13	G1/4	G2
VZ.2xDO.105C-3/500L	707	1,429	540	2,020	385	480	396	1,020	541	60	4xØ13	G1/4	G2
VZ.2xDO.205C-3/1000L	1,068	2,381	790	2,500	738	680	109	835	145	1,460	4xØ13	G1/2	G2
VZ.2xDO.305C-3/1000L	1,138	2,381	790	2,500	738	680	179	835	145	1,460	4xØ13	G1/2	G2



Vacuum units with three pumps



Product Description

- > Centralised vacuum supply with three pumps and vertical buffer tank
- > Redundant system that enables maintenance work to be done during operation

Ordering notes

Included in scope of delivery:

- > Three oil-lubricated rotary vane pumps mounted on one frame to conserve space
- > One vertical vacuum tank with condensate discharge valve and additional bypass system to separate the system
- > Three non-return valves integrated in the suction line of the pumps to maintain vacuum at standstill
- > Three particle filter elements to protect the pumps
- > Two independent control panels (400 VAC, 50/60 Hz) with current protection, pressure sensor and PLC for manual and automatic operation
- > Switching cabinet IP 55
- > Optional GFB hygiene filter element (Standard EN 773/3) with bypass system between the non-return valve and the load

Technical data

Item no.	Safety tank volume of vacuum tank [l]	Suction power at 50 Hz [m ³ /h]	Suction power at 60 Hz [m ³ /h]	Final vacuum [%]	Rated power at 50 Hz [kW]	Rated power at 60 Hz [kW]	Weight [kg]
VZ.3xDO.25C-3/300L	300	75	87	99	3x0.75	3x0.90	240
VZ.3xDO.25C-3/500L	500	75	87	99	3x0.75	3x0.90	300
VZ.3xDO.40B-3/500L	500	120	144	99	3x1.1	3x1.35	395
VZ.3xDO.60B-3/500L	500	180	125	99	3x1.5	3x1.8	410
VZ.3xDO.105C-3/500L	500	315	375	99	3x2.2	3x2.7	520
VZ.3xDO.105C-3/1000L	1,000	315	375	99	3x2.2	3x2.7	580
VZ.3xDO.150C-3/1000L	1,000	450	540	99	3x3	3x3.6	620
VZ.3xDO.205C-3/1000L	1,000	615	735	99	3x4	3x4.8	850
VZ.3xDO.305C-3/1000L	1,000	915	1,095	99	3x7.5	3x9	880



Dimensions

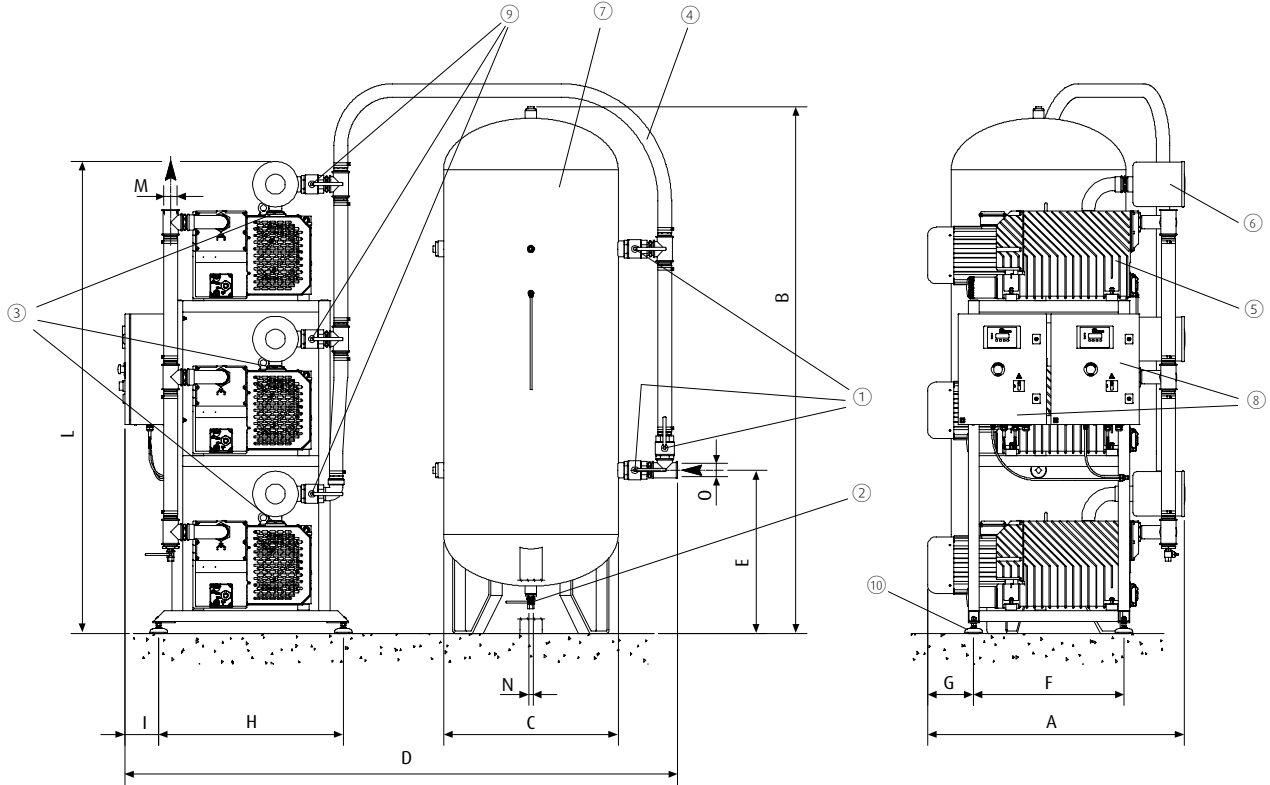

① = Vacuum tank bypass valve ② = Condensate blow-off valve ③ = Check valve ④ = Reinforced PVC tubing ⑤ = Vacuum pump
 ⑥ = Filter ⑦ = Vacuum tank ⑧ = Switchbox ⑨ = Vacuum pump blocking valve ⑩ = Vibration absorber

Item no.	A [mm]	B [mm]	C [mm]	D [mm]	E [mm]	F [mm]	G [mm]	H [mm]	I [mm]	L [mm]	M	N	O
VZ.3xDO.25C-3/300L	750	1,677	500	1,821	612	670	40	550	245	1,407	G1	G1/2	G1
VZ.3xDO.25C-3/500L	750	2,139	600	1,810	708	670	40	550	245	1,407	G1	G1/2	G1
VZ.3xDO.40B-3/500L	750	2,142	600	2,071	708	670	40	550	245	1,567	G1	G1/2	G1 1/2
VZ.3xDO.60B-3/500L	796	2,142	600	2,045	708	670	40	550	245	1,592	G1	G1/2	G1 1/2
VZ.3xDO.105C-3/500L	874	2,142	600	2,515	708	670	109	550	245	1,643	G1 1/2	G1/2	G1 1/2
VZ.3xDO.105C-3/1000L	874	2,381	790	2,509	738	670	109	550	245	1,643	G1 1/2	G1/2	G1 1/2
VZ.3xDO.150C-3/1000L	897	2,381	790	2,453	738	670	129	550	245	1,643	G1 1/2	G1/2	G2
VZ.3xDO.205C-3/1000L	1,068	2,381	790	2,504	738	680	109	835	145	2,133	G2	G1/2	G2
VZ.3xDO.305C-3/1000L	1,138	2,381	790	2,500	738	680	179	835	145	2,133	G2	G1/2	G2



FIPA Side channel blowers

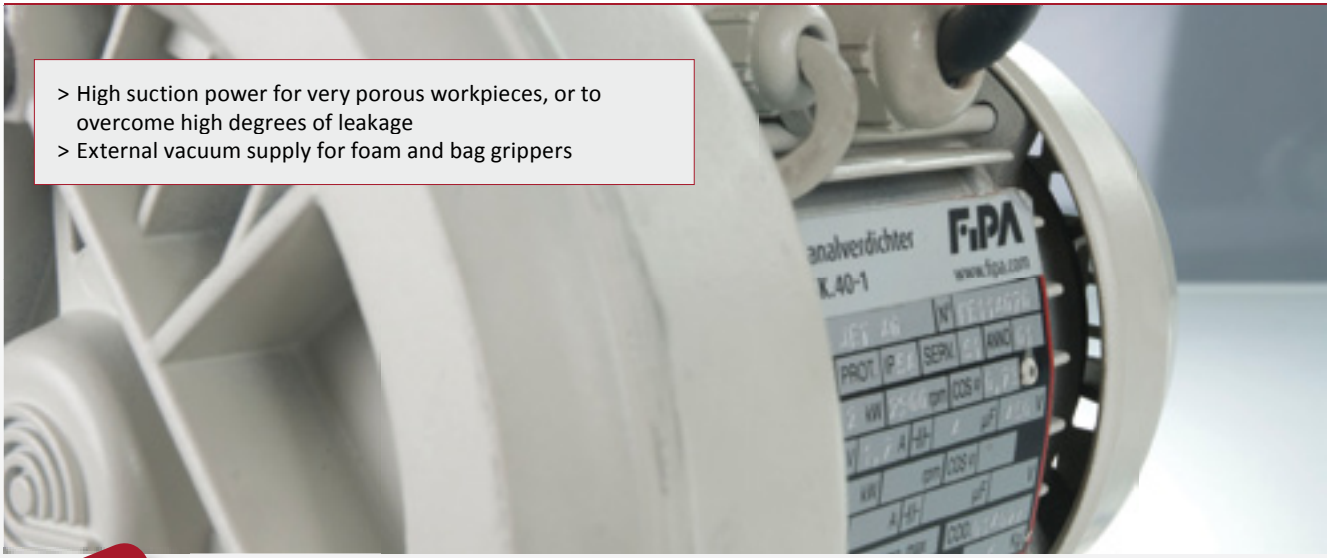

- > High suction power for very porous workpieces, or to overcome high degrees of leakage
- > External vacuum supply for foam and bag grippers

On request



Side channel blowers - single-stage and double-stage

- > Handling of porous workpieces, such as cardboard boxes or untreated wooden plates
- > Double-stage design offers higher suction power at the same vacuum level for effective leak compensation
- > Suitable for use in wet and dry areas
- > Suitable for continuous operation
- > Horizontal and vertical installation
- > Practically maintenance free



Accessories

Additional silencer for side channel blowers

- > Open silencer for "further processing" of the exhaust air

> See page 618



Vacuum pressure changeover valve

- > Fast switching between vacuum mode (vacuum) and pressure mode (blow-off)
- > Enables short cycle times
- > Installation of a vacuum relief valve at the suction inlet is recommended

> See page 619



FIPA Side channel blowers

Examples of use

- > Vacuum generation for the TC/TL series foam grippers or TG series bag grippers
- > Handling of cardboard packaging with vacuum cups
- > Pneumatic conveying
- > Extraction of particles which are not too coarse, such as wood dust in woodworking

Principle of operation

- > Side channel blowers use the momentum principle for generating vacuums or compressed air
- > The rapidly rotating blade wheel ① accelerates the air within the annular housing ②
- > In addition, a swirling motion is created in the side channels which increases efficiency
- > The shape of the inlet channel [V] or the outlet channel [Ex] allows air to be suctioned in or expelled

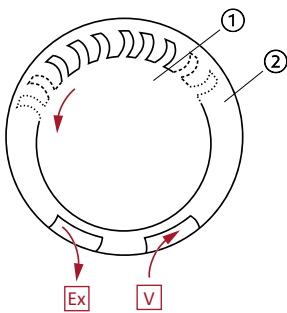

Performance characteristics

- (a) Characteristic of ejectors
- (b) Characteristic of vacuum pumps
- (c) Side channel blowers have an extremely high output, but achieve only a low ultimate vacuum

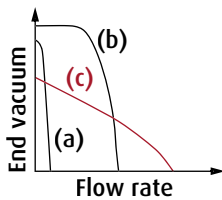



Notes:

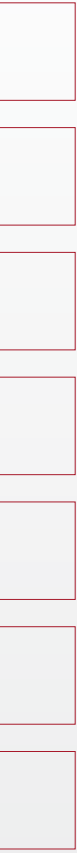

Lined area for notes, featuring a thick vertical red line on the left and horizontal grey lines.



Vacuum tanks 5 - 60 liters



Product Description

- > Storage for compressed air, vacuum and non-aggressive liquids
- > Energy saving assembly of compressed air and vacuum
- > For compressed air / vacuum networks with fluctuating demand
- > For preventing frequent startup of the compressor system
- > To cover high demands short-term
- > As supplement to screw / piston compressors, rotary compressors or vacuum pumps

Notes

- > 92.001: Two fittings in line with G1/2-female with 90° offset
One fitting per front face with G1/4-female
- > 92.002 to 92.004: One fitting in line with G1/2-female
2 x one fitting with G3/4-female and distance 120 mm and 1 x one fitting with G3/4-female on the front faces

Technical data

Item no.	Safety tank volume [l]	Operating pressure [bar]	Medium	Design	Weight [kg]
92.001	5	0 - 11	Compressed air / vacuum	Aluminium	1.7
92.002	10	0 - 11	Compressed air / vacuum	Aluminium	2.4
92.003	20	0 - 11	Compressed air / vacuum	Aluminium	3.7
92.004	60	0 - 11	Compressed air / vacuum	Aluminium	9.3

Dimensions

d1	d2	D [mm]	L [mm]
G1/2	G3/4	152	356
G1/2	G3/4	206	355
G1/2	G3/4	245	500
G1/2	G3/4	276	1,111

Dimensions

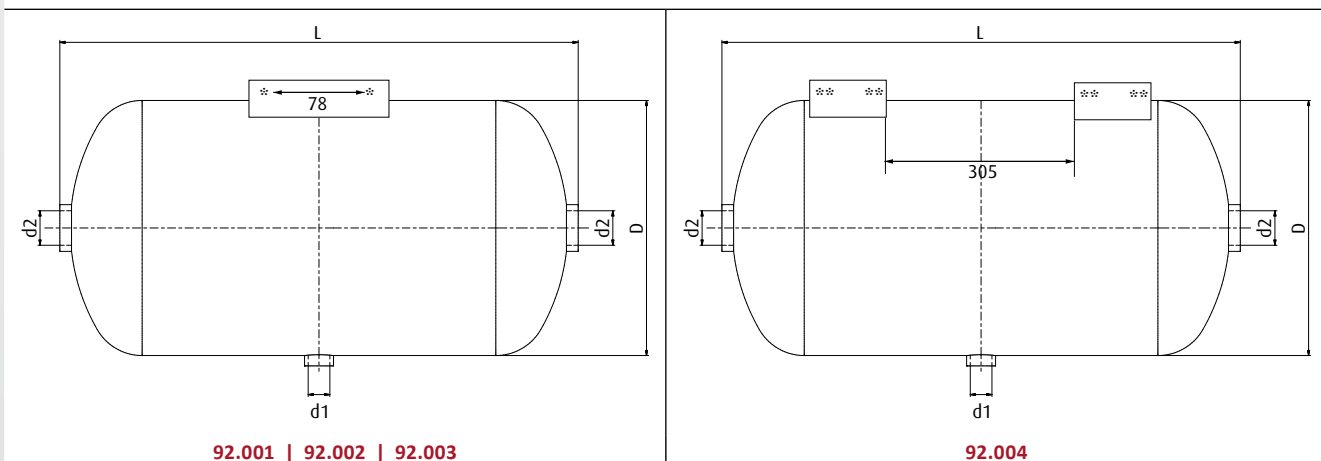

92.001 | 92.002 | 92.003

92.004

* = Two pairs of fixing bores, each with 2x M12x14 ** = Two pairs of fixing bores, each with 4x M12x14



Additional silencer for side channel blowers



Product Description

- > Silencer with direct opening
- > Suitable for "processing" of the exhaust air: e.g. ventilation or heating of halls or use as silencer and release into the open

Dimensions

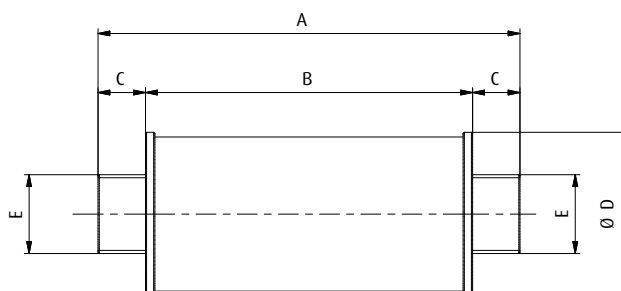

Item no.	E	A [mm]	B [mm]	C [mm]	Ø D [mm]
72.038	G1	178	138	20	69
72.039	G1 1/4	242	138	52	69
72.040	G1 1/2	232	168	32	80
72.041	G2	262	198	32	89
72.042	G2 1/2	262	198	32	100



Electro-pneumatic reversing valves for side channel blowers



Product Description

- > Operation of a side channel blower as a vacuum pump for suction or compressor for blow-off
- > Blow-off volume flow is directed to the vacuum cup / load, without reversing the direction of rotation of the blower
- > Three setting positions: Suction, blow-off, neutral
- > Working principle: Rotation of a cylinder, which is operated by an electrical motor-driven actuator

Notes

- Please note for the neutral position (0°):
- > If operation with closed suction inlets cannot be excluded, a vacuum limiting valve (safety valve) must be installed before the suction inlet

Technical data

Item no.	Suction power [m³/h]	Power supply [VDC]	Power consumption [W]	Duty ratio [%]	Direction of rotation [°]	Mean control time [s]	Minimum time interval between successive cycles [s]	Protection class	Weight [kg]
33.074	300	24	10	100	-45 / 0 / +45	0.5	0.1	IP55	3.2

Dimensions

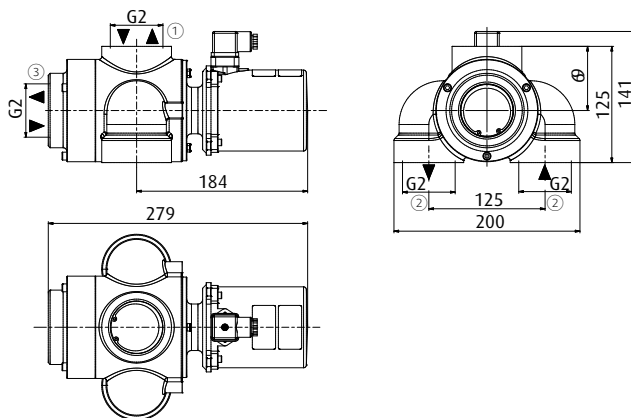

Wiring diagrams

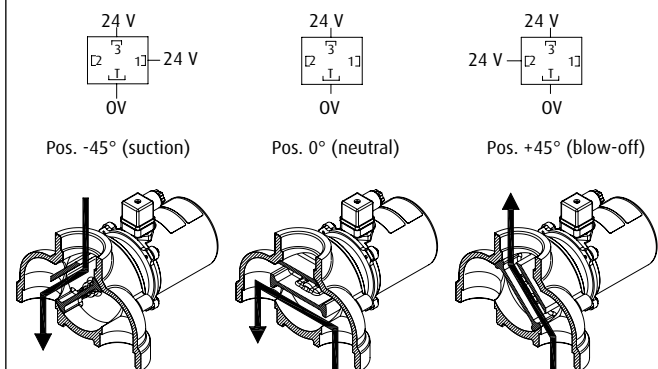

① = System connection ② = Side channel blower connection ③ = Air inlet / outlet

